

SUBURBAN MANUFACTURING COMPANY  
Post Office Box 399  
Dayton, Tennessee 37321

SUBURBAN  
DYNATRIL  
FURNACES

Service Manual

**NT- 12S NT- 16S NT-20S**  
**NT-24SP NT-30SP NT-34SP**  
**NT-25K NT-30K NT-35K**  
**NT-42T**

	INDEX	Page
Safety		2
Furnace Model Information		2
General Service Information		3
Installation		
Venting		3
Return Air		4
Ducting		4
Gas Pressure Requirements/Service Tools		4
Sequence of Normal Operation		7
Operation Information		7
Maintenance		8
Cautions		9
Furnace Removal		9
Service Hints, Diagnosis and Corrective Measures for Suburban 12-volt DC Electronic Ignition Furnaces		10
Service Center Information/Flat Rate Schedule		16
Limited Warranty		17
Optional Extended Warranty		18
Service Test		19
Service Answer Sheet		22

## SAFETY

As a part of repairing any gas appliance, be certain to check all gas connections both inside and outside the appliance (furnace) with a proper leak check solution or a leak detector before returning the equipment to service. Also make certain the furnace operation and functions are in accordance with the written instructions supplied with each furnace.

## FURNACE MODEL INFORMATION

Models	Input	BTU/HR	Type Gas	Electrical
NT-12S		12,000	Propane12-VDC;	2.8-amps
NT-16S		16,000	Propane12-VDC;	2.8-amps
NT-20S		19,000	Propane12-VDC;	2.8-amps
-----		-----	-----	-----
NT-24SP		24,000	Propane12-VDC;	3.5-amps
NT-30SP		30,000	Propane12-VDC;	5.5-amps
NT-34SP		34,000	Propane12-VDC;	7.5-amps
NT-42T		42,000	Propane12-VDC;	9.0-amps
-----		-----	-----	-----
NT-25K		25,000	Propane12-VDC;	6.5-amps
NT-30K		30,000	Propane12-VDC;	6.5-amps
NT-35K		35,000	Propane12-VDC;	6.5-amps

## GENERAL SERVICE INFORMATION

Suburban DYNATRIL furnaces installed in recreational vehicles are classified as Forced Draft Furnaces. A forced draft furnace utilizes a sealed combustion chamber that is vented to the outside atmosphere. The intake air for combustion is also taken from outdoors and is completely isolated from the exhaust. A motor is used to drive an impeller wheel to draw intake air into the chamber to support combustion and force the exhaust gases through the furnace chamber to the outside atmosphere. A second impeller wheel (driven by the same motor yet totally isolated from the combustion air) is used to circulate room air across the furnace chamber where it is heated. The blower then forces the hot air into the living area either through a duct system or through a front grille on the furnace cabinet on direct discharge models.

There are several differences between a forced air furnace designed for recreational vehicles and most central furnaces designed for residential use. The major difference is that in a forced draft combustion furnace, a separate combustion air blower must deliver a predetermined volume of air into the burner chamber before ignition of the main burner can occur. Once the main burner flame is established, it is sustained by the air supplied by the blower.

Suburban furnaces operate on 12-volt DC current that is supplied either by a 12-volt battery or a converter system. A recreational vehicle furnace that is specifically designed for "park model" trailers operates on 115 volts AC. These are designed and tested under the same standards as the 12-volt models.

Suburban forced draft combustion furnaces used in recreational vehicles are designed for use with Liquefied Petroleum (LP) Gas. The operating pressure is between 10.5" - 13.0" of water column. Although a few recreational vehicle furnaces are approved for use with natural gas, one should never attempt to convert such a unit to natural gas unless the conversion is approved by the manufacturer of the furnace.

## INSTALLATION

There are several important aspects of the installation that will pertain to all Suburban forced draft furnaces illustrated in Figures 1, 2 and 3. They are:

1. Venting
2. Return Air
3. Ducting

Refer to the furnace installation manual for each model requirement.

**VENTING** - By definition of a forced draft combustion furnace, it must be vented to the outside atmosphere and also draw combustion air from outdoors. Therefore, it is imperative that the vent be unobstructed and tightly sealed. There must be a separation of the exhaust and intake air. The vent must be straight. There can be no offsets or turns in the vent. All vent tubes that connect to the furnace exhaust and intake must overlap a minimum of 1/2". Figure 4 illustrates a typical vent installation.

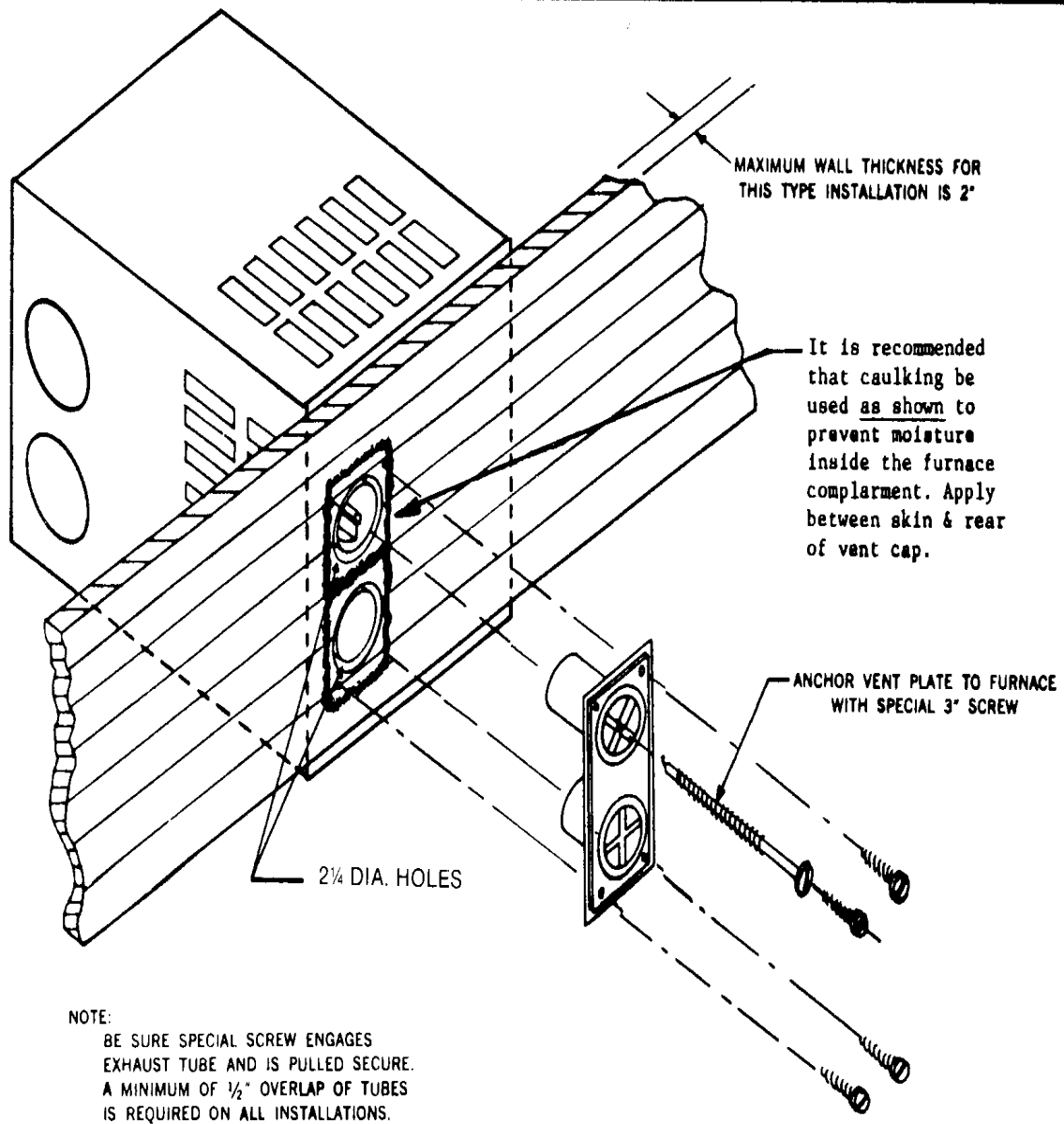

VENT CAP INSTALLATION

Figure 2

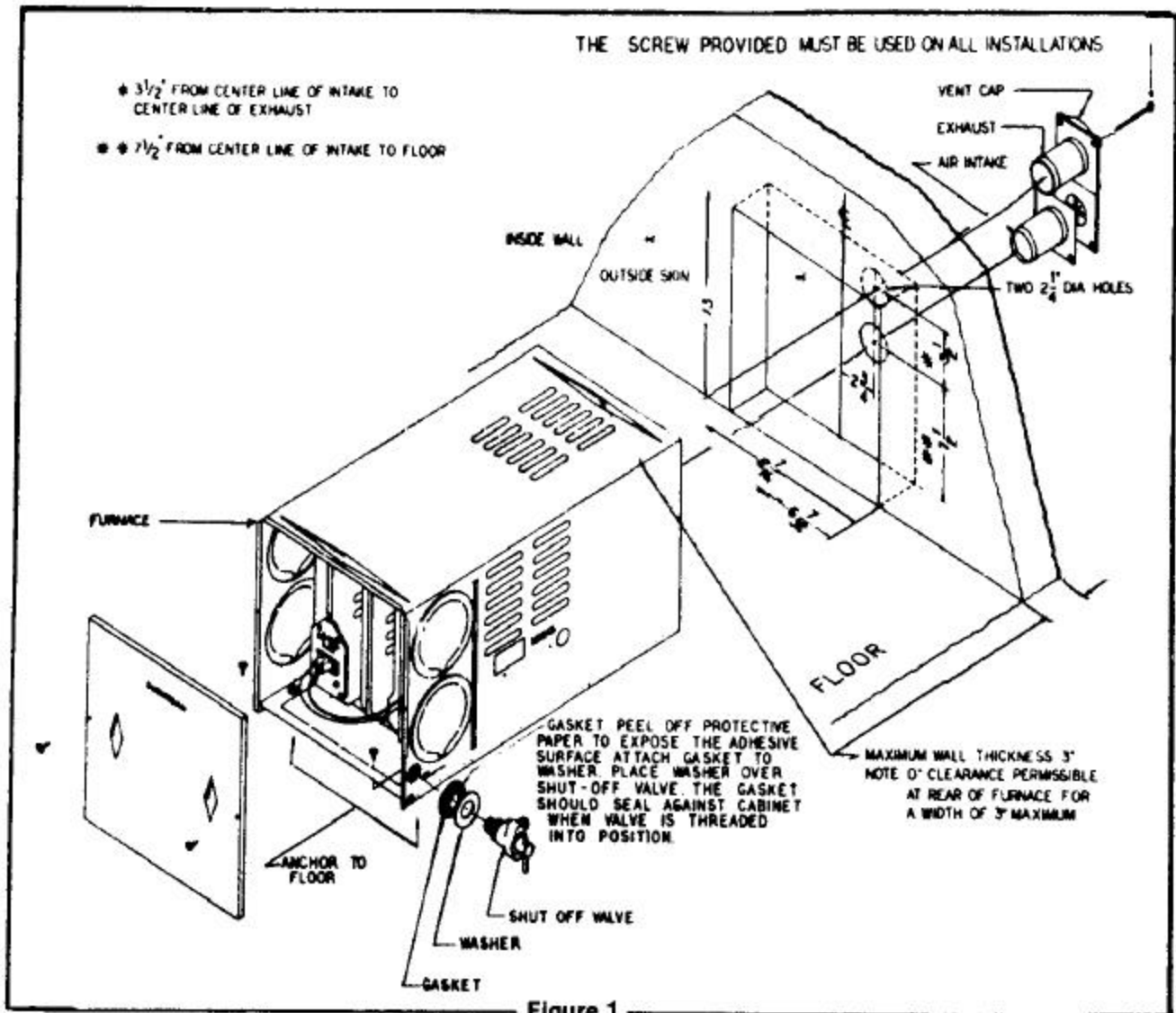

Figure 1

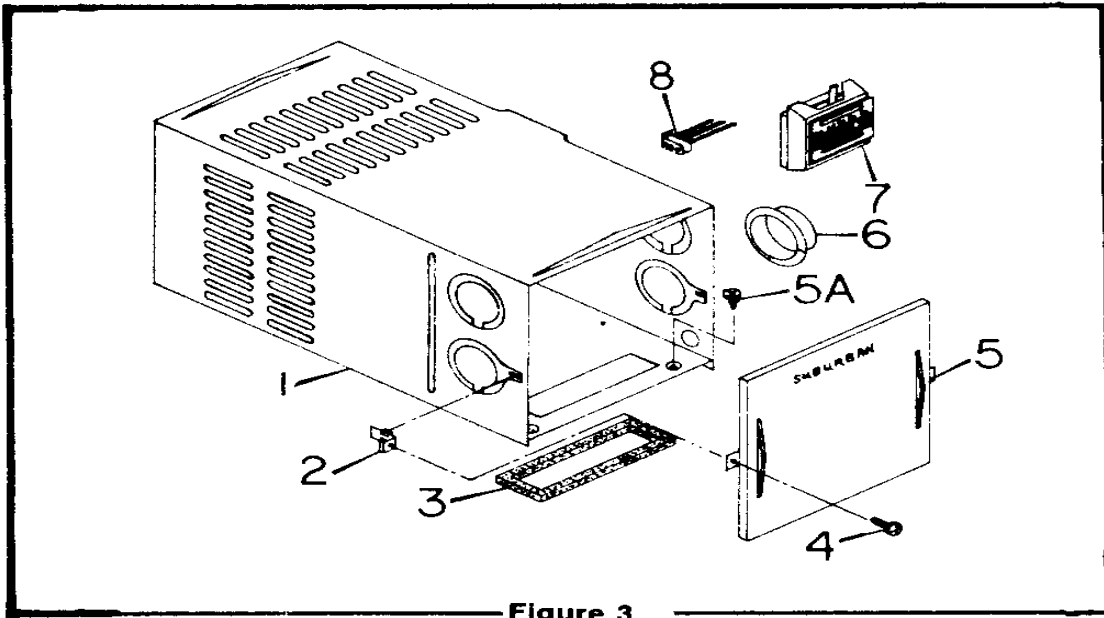
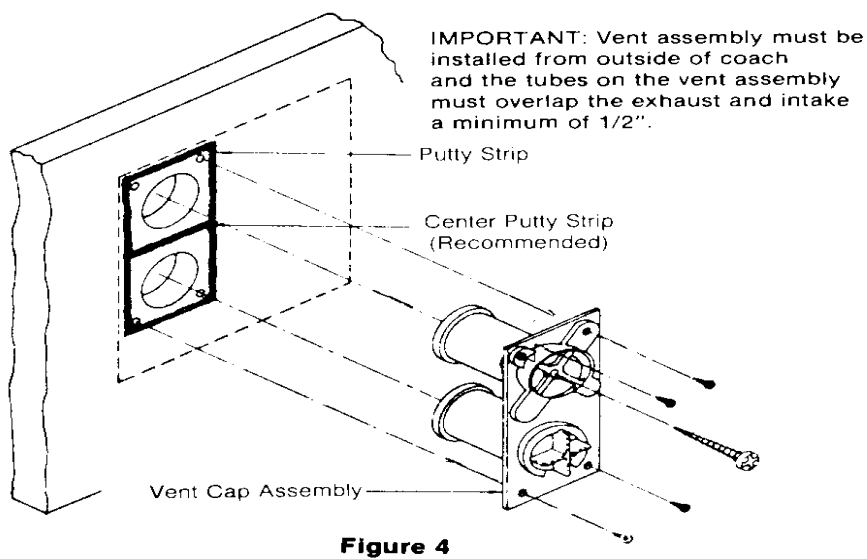
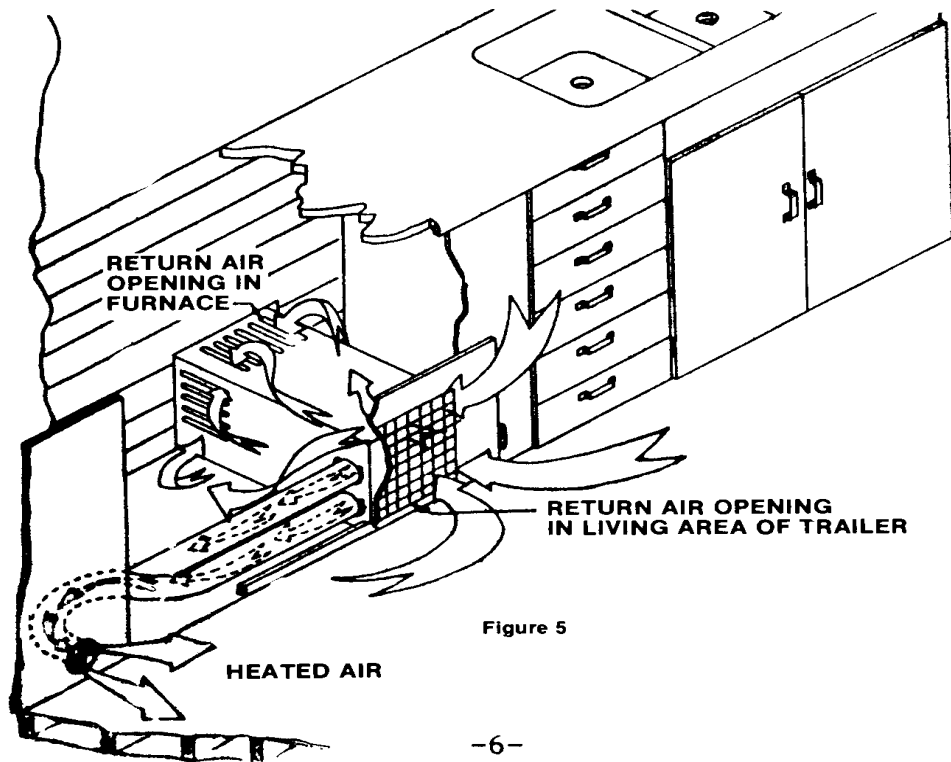

Figure 3



## SEQUENCE OF NORMAL OPERATION

The electronic ignition system is made up of three main parts: the module board, the electrode assembly, and the electrode wire. The module board is the brain of the electronic ignition system and it has several functions.

1. When the blower reaches approximately 75% of the normal rpm and sufficient airflow is established, the sail switch engages and completes a 12-volt circuit through the limit switch to the module board. **(NOTE: Low voltage power supply will not provide sufficient motor rpm to engage the sail switch.)**
2. After a 12-18 second delay, 12-volt current will pass through the module board to the solenoid valve. The current to the valve opens it and allows gas to the main burner, simultaneously, the module board sends high voltage through the electrode wire to the electrode assembly. The voltage seeks a ground between electrode and ground probe and a spark occurs. The spark then ignites the main burner.
3. The module board also performs the lockout function in cases where the spark fails to light the burner. When lockout occurs, the spark stops, the voltage from the module board to the gas valve is discontinued, and the valve closes. The unit will remain in lockout and the blower will continue to run until the thermostat is turned off. Turning the thermostat off disengages the lockout function of the module board. After the blower has stopped, the ignition sequence can be started again.

## OPERATION INFORMATION

Figure 6 illustrates a typical electrical circuit for direct ignition models. The room air blower must be operating at approximately 75% of the normal rpm at 12-volts DC before ignition can occur. This is unlike most residential furnaces that have burner operation without the blower running.

The operation of a forced draft combustion furnace is controlled through a 12-volt thermostat (24-volt thermostat in the case of a park model furnace). When the thermostat is set above room ambient, the contacts close completing a circuit through the coil of the time delay relay. The contacts on the relay then close, completing a circuit through the windings of the motor and the motor comes on.

As the motor reaches approximately 75% of its normal rpm, the airflow generated by the room air blower pushes against the paddle on the sail switch (sometimes referred to as a microswitch or an air prover switch) sailing it in and closing the contacts. A circuit is then completed through a high temperature limit switch to the module board on a direct ignition furnace.

On a direct ignition furnace, as current passes through the ignition module to the valve, a high voltage spark is produced at the electrode assembly located over the burner. Simultaneously, the valve opens, gas flows into the burner and is ignited by the spark.



All DYNATRIL direct ignition furnaces must have a flame sensing circuit through the control module that senses the presence of main burner flame. If proper flame sensing is not obtained or if the burner fails to light, the furnace must go into 100% lockout. When lockout occurs, the valve closes and will remain closed until the thermostat circuit is broken. Re-ignition will not occur automatically. If it could, it would not be 100% lockout.

While 100% lockout is a safety factor, it can prove to be frustrating for the RV owner who has experienced lockout problems. Not only can a lockout problem be difficult at times to diagnose, it will result in continuous operation of the furnace blower (that is, until the thermostat circuit is broken) and can drain the battery if the owner is not in the recreational vehicle.

The solution for this complaint is not to try and eliminate the lockout function of the furnace, but rather to find the cause for lockout (which will be covered later), and correct it.

The motor circuit contains a time delay relay (see wiring diagram). The purpose of a time delay relay is to provide a means of the blower operation on initial startup and after the thermostat is satisfied. When the thermostat contacts open, the circuit through the coil of the time delay relay is broken and the contacts open after approximately 3-5 minutes, depending on the furnace model.

## MAINTENANCE

Preventative maintenance is essential if an RV owner is to have reliable, safe operation of his furnace. By far, the two most important areas to watch closely in order to assure safe, reliable operation, are the venting and the main burner.

An obstruction in the vent or main burner will reduce the intake of combustion air that results in incomplete combustion. Whenever incomplete combustion occurs, the by-products are carbon monoxide (CO) and soot. If the furnace outside exhaust vent shows black soot may be forming, the furnace should not be operated until the problem is corrected. Possible causes are air restriction combustion air, low gas pressure, dirty burner, slow motor, low voltage, etc.

If operation of the furnace continues under these conditions, it could result in serious injury to the occupants of the RV or even death.

Cleaning of the main burner and an inspection of the venting system should be done at least once a year, preferably just before the beginning of the heating season. Some RV owners and service personnel have the false assumption that if a furnace has not been used, it will not require cleaning. NOT SO! A furnace that has not been used for some time could be more in need of cleaning than a furnace that has been used extensively.

Dust and lint should be removed from the room air blower wheel and sail switch. A buildup of dust and lint on the blower wheel can cause the motor to drag and not generate enough airflow to engage the sail switch. Dust accumulation on the sail switch will restrict the travel of the actuator arm to where the airflow across the paddle will not sail it in and complete the valve circuit.

A yearly inspection should be made of all gaskets on the furnace. If any gaskets show signs of leakage or deterioration, they must be replaced to assure proper pressurization of the sealed combustion chamber.

Motors used on RV furnaces are permanently lubricated and do not require oiling.

### CAUTIONS

1. Never operate the furnace with the electrode wire disconnected or with the electrode assembly removed from the furnace.
2. Never use a battery charger to checkout an electronic ignition furnace -use a 12-volt battery.
3. Never use a screwdriver or any part of the electrode assembly while the furnace is in operation.
4. Be certain that the spark from the electrode never reaches the flame sensor portion of the electrode assembly. (See Figure 2 for correct gapping).
5. Be sure the electrode assembly screws are snug at all times, especially after the electrode has been removed and reinstalled.
6. If the module board is found to be defective, it must be replaced - it is not field repairable. Any attempts to repair the board may alter the board and cause it to operate in an unsatisfactory manner.
7. Ensure that the gap between electrode and ground is always 1/8". The gap between the ground and the flame sensor should be approximately twice the gap between electrode and ground to ensure no sparking to sensor. Sparking to sensor will damage the module board (see Figure 7).

### FURNACE REMOVAL

To replace parts or service the latter generation furnaces, the M and S series, it is necessary to follow these steps:

1. Disconnect gas and power supply.
2. Remove vent cap assembly (4 sheetmetal screws and one 3" exhaust baffle screw, see Figure 2).
3. Remove the cabinet front.
4. Remove the shipping screw securing the chamber shield to the cabinet.
5. Pull chamber outward completely to gain access to all controls and parts for adjustment or replacement.

NOTE: Our service technicians are available to assist you in making repairs or parts replacements from 8:00 a.m. to 5:00 p.m. EST, Monday through Friday (except holidays), by calling (615) 775-2131.

SERVICE HINTS, DIAGNOSIS, AND CORRECTIVE MEASURES  
FOR THE IGNITION SYSTEMS OF  
SUBURBAN 12-VOLT DC ELECTRONIC IGNITION GAS FURNACES

Furnaces with Direct Spark Ignition:

Each step in this operation must be completed in the listed order before the next function will occur. To properly diagnose a malfunction and correct it, it must be determined at what step the operation of the furnace failed.

1. When the temperature drops to a set temperature, the wall thermostat contacts close.
2. The fan relay coil is energized in the thermostat relay, completing the circuit to the blower motor. (Some models equipped with a time delay relay have a 5-25 second time delay after the thermostat contacts close).
3. The motor starts and, after reaching 75% of its normal rpm, the room air blower wheel or blade activates the sail switch (microswitch), sending current to the temperature limit switch (a normally closed switch), and on to the module board.
4. When energized, the module board has a built-in 15-20 second delay, allowing the combustion air to purge the combustion chamber.
5. The module board supplies a high-voltage spark through high-tension wire to the electrode assembly, at the same time sending voltage to the gas valve, opening the valve.
6. Burner ignites.
7. The sensor probe (left probe) signals the presence of flame and the spark stops. (If flame is not established within 7 seconds, the system closes the gas valve and goes into lockout).
8. The fan switch (normally open) closes on temperature rise. This does not apply to models with the time-delay relay. These models will keep the motor running for 3 to 5 minutes by the delay of the relay.
9. The gas valve closes when either the limit switch or thermostat contacts open.
10. The blower motor goes off when the fan switch or time delay relay opens.

Do not use a battery charger to power or test the furnace, as they sometimes provide more than the 14.5 volts DC that will damage the control module board.

All testing and repair should be done by qualified personnel only. Do not use a screwdriver or touch any part of the electrode assembly while the furnace is running.

Do not operate the furnace with the high-tension lead wire disconnected or the electrode assembly removed from the burner access plate.

Do not perform any high-pot tests on this furnace!

#### A. Thermostat Is Calling For Heat, but The Blower Does Not Run:

1. Check for 12 volts DC at the furnace connection. Correct power source if "0" volts or below 12 volts DC.
2. Check all wiring for correct polarity (refer to wiring diagram), loose connections and possible shorts.
3. Check the wall thermostat and wiring for continuity. Be sure thermostat points are contacting.
4. With thermostat points closed, check for circuit completion across terminals 2 and 4 of the thermostat relay. If no continuity, and wiring to the relay is okay, replace the relay.
5. If there is continuity across terminals 2 and 4, and the wiring to the motor is okay, replace the motor.
6. On time delay relay models, allow 3 to 10 seconds for the circuit to be completed to the motor, as the coil in the time delay relay must heat up to close the contacts.

#### B. Blower Is Noisy:

1. Check for lint accumulation or debris on the blower wheels or possible damage to the wheel.
2. Check for excessive voltage and correct, if present.
3. Check polarity. If reversed, the motor will whine and run backward. Air delivery will be too low to close the microswitch.
4. Wheel may be hitting the housing. Remove the combustion air housing and adjust the wheel with a T-handle 1/8" Allen wrench. On the room air wheel side, a 90° angle 1/8" Allen wrench will be needed to remove or adjust the wheel.
5. At times, insects such as mud daubers and wasps will build nests inside the combustion air housing, coming in from the fresh air intake. Remove any foreign materials and check the combustion air wheel for warpage.
6. If the bushings of the motor are worn and noise persists, replace the motor. Check both wheels for balance and, if not proper, replace the wheel or wheels.

#### C. Blower Runs but Burner Does Not Light:

1. Make sure the manual shut-off valve is in the "ON" position.
2. Possible air in the gas lines. Reset the thermostat and cycle the furnace several times to bleed the system.
3. Check the gas supply. Be certain 11" WC pressure is present while the furnace is operating. If not, adjust the pressure regulator.
4. Check the wiring for proper polarity.
5. Check for proper clearances down the sides and across the top for return air to feed the room air blower. Each model furnace has a minimum requirement of return air outlined in the installation manual. With improper return air, the air volume may not actuate the sail switch that sends voltage to the module board. All models must have 1" clearance along the sides and across the top except the NT-34, -42 and -45 models, which require 2" on the sides and top.

6. Check the ducting of the furnace to determine proper airflow away from the furnace. See the installation manual for correct duct requirements. If the ducts have severe bends or kinks in the hose, the airflow may be restricted enough to cause the microswitch to bounce back from the volume of air hitting the cabinet front. This again will not allow voltage to the module board. Many times, a furnace will operate satisfactorily on the bench or without the cabinet door on the unit. Check for microswitch energizing when this happens. Correct ducting for proper airflow and/or replace the microswitch (could be stiff).
7. If the furnace will ignite with the cabinet front off, but will not with the cabinet front secured, and the ducting is free, check the gaskets around the burner access door. If the burner access is not properly sealed, air may be deflected from the cabinet front into the burner area, thus disturbing air and gas mixture for proper ignition.
8. Check for 12 volts DC on both sides of the limit switch. If there is voltage on one side of the switch, but not on the other, replace the switch. If voltage is present on both sides of the switch, proceed to Step 9.
9. Check for 12 volts DC at the power terminals on the module board (refer to the wiring diagram - red wire positive and yellow wire negative). If no voltage, check wiring from the limit switch. Correct wiring.
10. If sparking is audible approximately 15 seconds after the blower starts, but no ignition, check the high-tension wire for continuity, grounding and secure connections. Repair if necessary.
11. Make sure electrode is not grounding to burner, the gap between the spark probe and the ground probe is 1/8" (see Figure 7), and the ceramic insulator is not cracked, broken or sooted. Adjust, clean or replace as necessary.
12. If sparking is not audible, check the module board and observe if the neon bulb on the circuit board is flashing during the trial for ignition. Remove the white plastic wire connector from the circuit board. Clean the board terminals on back with a soft rubber eraser. Check the little pin terminals in the plastic connector for good contact. Reinstall connector. If the tube does not flash, replace the module board.
13. Check for voltage at the gas valve during the trial for ignition. If no voltage and connections are okay, replace the board.
14. If the valve does not open with 12 volts DC present, replace the valve.
15. If the electrode sparks and the valve opens but the burner will not light, check the gas supply for 11" WC pressure to the main burner orifice. If 11" is present to the valve but not to the orifice, replace the valve. Check vent and air intake installation. Check the main burner for correct relationship to the electrode assembly (burner should be 3/16" from the spark probe and sawports or charge ports directly under the spark gap). Check main burner for soot build-up in ports (see Figure 8). Clean cast-iron burners by passing a hacksaw blade through the sawports, being careful not to enlarge the openings. Wire brush stainless tube burners to remove build-up.
16. Check the combustion air wheel for proper rotation. Insufficient air will not sustain the flame if the wheel is installed backward.

#### D. Burner Ignites But Shuts Off:

1. Check to be certain that flame sensor is over slots in the main burner and that the main burner flame is burning against the tip of the flame sensor - adjust by bending the sensor probe. **NOTE: Sensor probe should be in the inner blue cone of the burner flame, approximately 1/4" to 5/16" above the burner.**
2. If the burner still goes off and into lockout, check the wire connections at the flame sensor and the module board.
3. If wire connections are okay, check for continuity through the flame sensor wire.
4. If the continuity of the flame sensor wire is okay, check with microamp meter in series with the flame sensor and flame sensor wire to be certain the flame sensor is generating at least seven microamps within seven seconds after the burner is ignited. Connect the meter as follows: (+) to sensor wire, (-) to sensor probe. Adjust the position of the sensor probe, check air adjustment and check for carbon deposits on the sensor probe if the reading is less than seven microamps.
5. When the flame sensor circuit is generating at least seven microamps, but the burner still goes off and into lockout, replace the module board.

#### E. Main Burner Will Not Shut Off:

1. Make sure the thermostat and contact points are open.
2. Check voltage at the valve terminals - should be "0" voltage.
3. Disconnect leads from the valve. If it does not shut off, replace the valve.

#### F. Continuous Sparking Of the Electrode:

1. Check the sensor wire and high-tension wire for good connections. Check for separations in either wire - repair or replace. Check to be certain that the flame sensor probe is over the slots in the main burner and that the main burner flame is burning against the tip of the sensor probe. Adjust by bending the probe or repositioning the burner. The burner flame should be a hard blue flame, lying down on the burner.

#### G. Erratic Blower and/or Thermostat Operation:

1. Check the wiring to the furnace.
2. Check for shorts in wiring.
3. Disconnect leads to the gas valve. If the furnace runs properly with the leads removed, replace the gas valve.
4. If the fan continues to run after the thermostat is satisfied and the burner goes off, the fan switch or the time delay relay is defective and needs to be replaced. If the fan comes back on after a short period of time (within one minute) and cuts off and on, replace the fan switch.
5. If the thermostat is not satisfied (points still made) and the fan cuts on and off, replace the motor (thermal overload switch is defective.)

## H. Unit Going Into Lockout Only Once In A While:

1. Thoroughly check the electrode and burner air adjustments.
2. Lockout can occur if the gas pressure fluctuates at the time that the thermostat calls for heat. Pressure fluctuations can be caused by a malfunctioning gas bottle regulator, and obstruction or a kink in the gas line, or moisture in the gas bottle regulator or in the gas lines. It is difficult to check for these fluctuations that will not noticeably affect any other appliance in the coach. However, isolating the furnace from the coach gas system will determine if the gas system is responsible. This isolation procedure can be done by connecting a separate upright bottle, regulator and gas line directly to the furnace, eliminating the coach gas system. If the occasional lockout still exists, then the furnace should be thoroughly tested to determine the cause; however, if the furnace works properly on this separate system, then the coach gas system should be checked.
3. Check the furnace return air and warm air discharge to be certain sufficient airflow is present to engage the microswitch every time.
4. Check the microswitch to be sure it moves freely.
5. Remove the electrode and burner and clean them thoroughly.
6. When moisture in the gas system is suspected as being the problem, especially where the horizontal type gas bottle is being used, the following steps should be taken to prepare the gas system against further moisture problems.

### Corrective Measures:

1. Disconnect gas bottle and drain it completely dry of all gas and all moisture.
2. Disconnect and blow out all gas lines completely dry.
3. Check pressure regulator on the gas bottle. Replace if necessary.
4. Add the drying agent. One half pint of methanol alcohol per 100 pound bottle capacity is recommended.

### Precautions:

1. Never fill the gas bottle over 80%.
2. Do not use the gas bottle completely dry to avoid using up the drying agent.

We have found the above procedures to be effective in solving most occasional lockout problems; especially where the horizontal-type gas bottle is used. All of these steps must be performed as described for the preparation of a contaminated gas system to be 100% effective.

### 1. Repeated Module Board Failures:

1. Check to be certain that the electrode spark is not sparking against the flame sensor portion of the electrode assembly.
2. Check to be sure the module board or high voltage wires are not shorted to the chamber wrapper or other furnace parts.
3. Be sure the insulator covering the electrode wire connection on the coil of the module board is in place and the insulator behind the module board is in place.

4. Check the high voltage - 14.5 volts DC maximum  
High voltage could intermittently produce volt surges or AC spikes that could damage the module board. Supply voltage to furnace should be checked if repeated module board failures occur.
5. Be sure duct connections to the furnace are airtight. Seal duct collar connections to the furnace cabinet with duct tape, if necessary, to prevent hot air leakage. No air leakage should exist anywhere in the duct system, especially at connections on the furnace cabinet.
6. The high voltage electrode wire should be routed away from any 12 volt wires (except at grommet for sensor wire). No wires should pass over the module board.
7. Be sure the sensor wire terminal is tightly affixed to the sensor probe.
8. Be sure high voltage electrode wire is in good condition and properly positioned onto pierce point electrode or spade terminal.

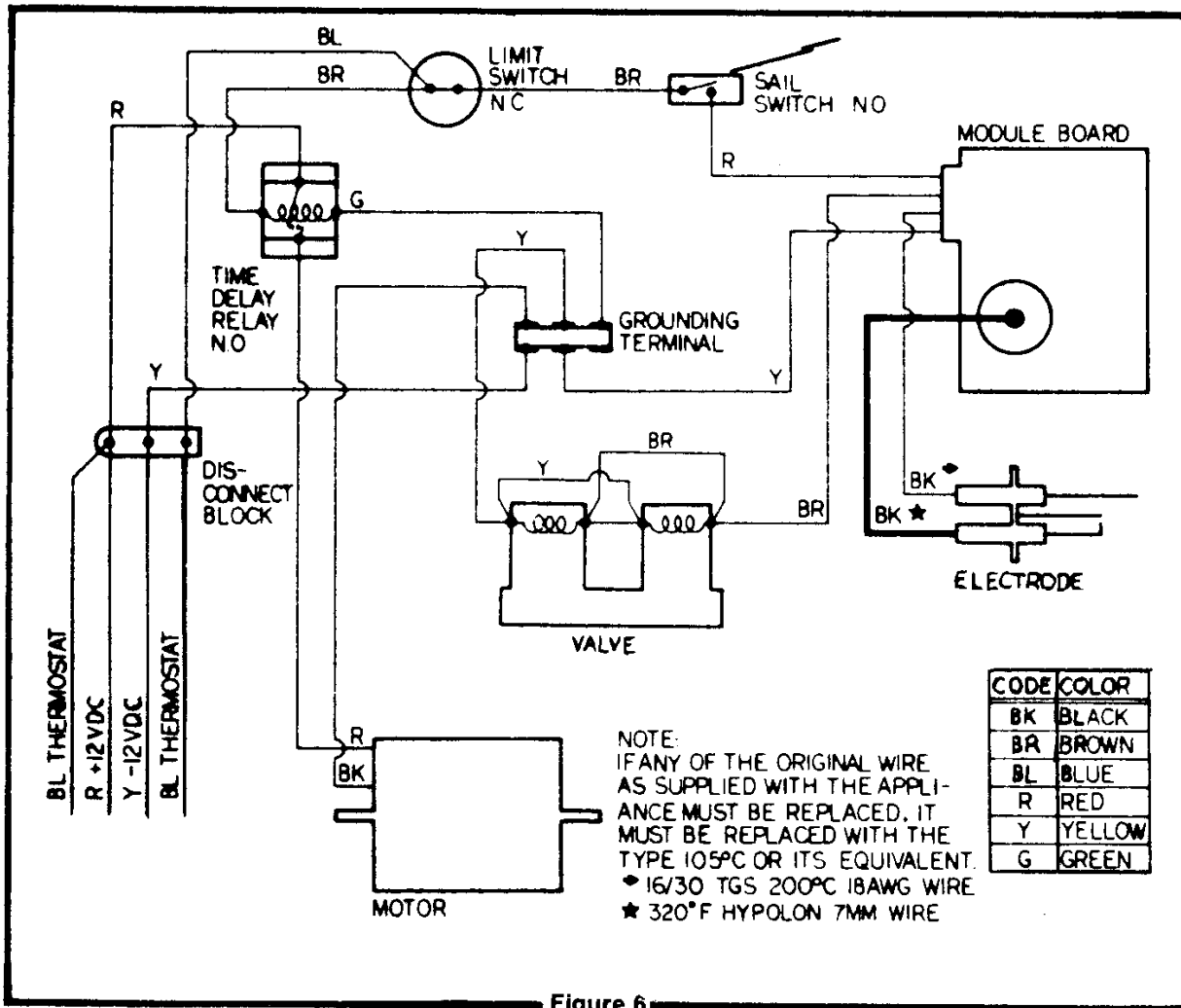

Figure 6



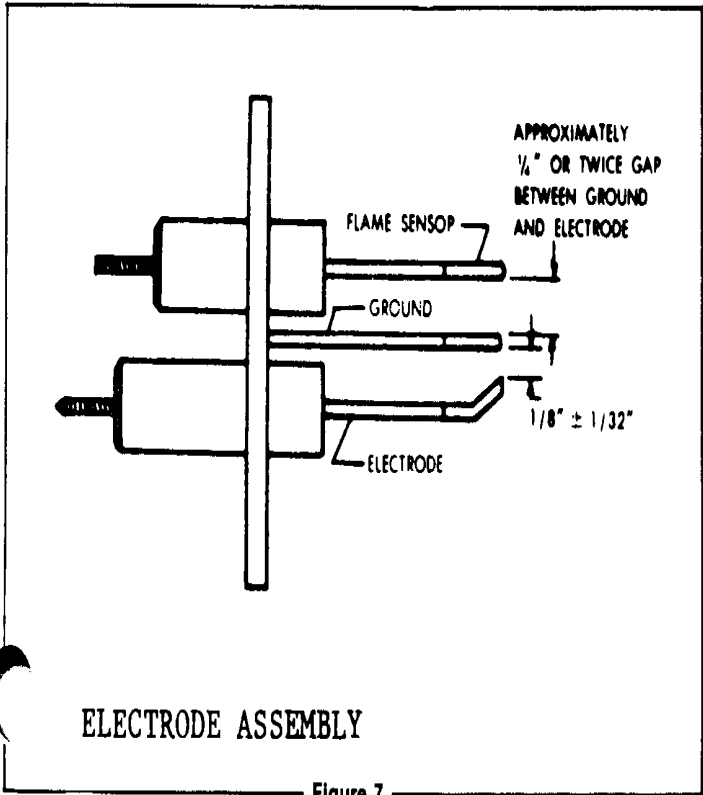

Figure 7

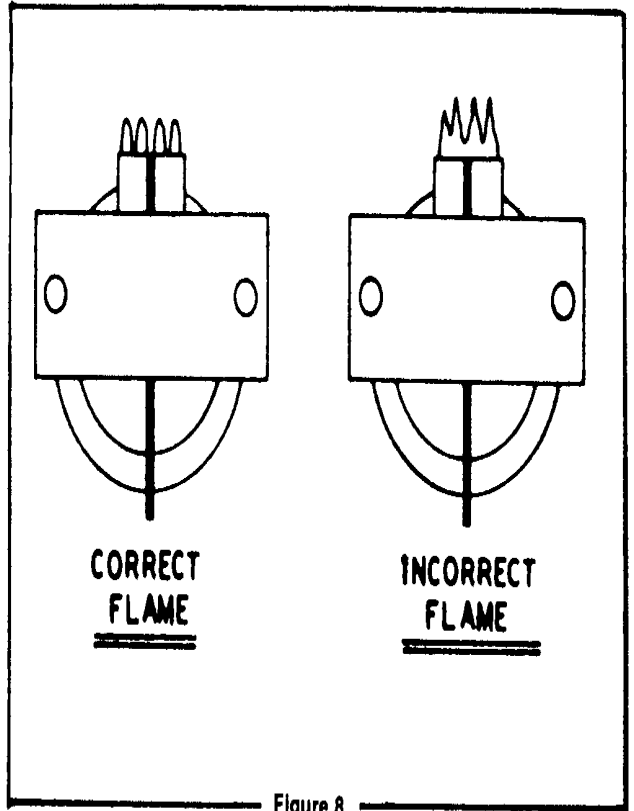

Figure 8

## **Service Center Information**

Suburban Manufacturing Company is always interested in adding qualified service agencies to our list of Recommended RV Service Centers. Our service centers receive substantial price breaks on all parts and units ordered from the factory. Their names, addresses, and phone numbers then appear in our Recommended RV Service Center List, which is supplied with each new unit. Customers who write or phone our office are referred to the service agency nearest them and they receive the latest revision of the list for their convenience when traveling.

If you would like more information on having your agency listed as a Suburban Recommended RV Service Center, please contact our Service Department at:

Suburban Manufacturing Company  
Post Office Box 399  
Dayton, Tennessee 37321  
Phone: (615) 775-2131

### **Warranty Repairs**

The following Flat Rate Labor Schedule shows our standard time allowances for labor on warranty repairs. In order to obtain reimbursement, the original work order or warranty claim form must be submitted to our office and must include the furnace model number, serial number and date of purchase. In the event that the repair involved replacement of a module board, gas valve, motor or combustion chamber, the defective part must also be returned to our factory for inspection~ the part and necessary paperwork should be returned together. Parts on approved claims will be replaced at no charge.

New factory-authorized replacement parts will be replaced at no charge if found to be defective within 90 days', labor is not paid for the part replacement. Defective parts must be returned to our factory for inspection, along with the Bill of Sale showing the purchase date of the part. Should our inspection reveal that the part is not defective, or was not the correct replacement, it will be returned to you and no further action will be taken.

NOTE: Any component part found to be defective must be replaced. Do not attempt to repair component parts. Use only factory-authorized replacement parts.

**For In-Warranty Recreational Vehicle Furnaces Only**  
**Forced Air Furnaces**

<b>Description of Labor</b>	<b>Set-Up Time</b>	<b>Replacement</b>
Replace Gas Valve	.5 .....	.6
Replace Main Burner - "S" Models	.5 .....	.5
Replace Main Burner - "K" Models	.5 .....	1.0
Replace Microswitch	.5 .....	.5
Replace Motor	.5 .....	1.1
Replace Time Delay Relay	.5 .....	.5
Replace Blower Wheel	.5 .....	.4
Replace Combustion Chamber (First Year Only)	.5 .....	1.5
Replace Thermostat	.5 .....	.2
Replace Transformer	.5 .....	.5
Replace Power Convertor Model NDP-16/30/45S	.5 .....	.3
Replace Electrode	.5 .....	.3
Replace Electrode Wire	.5 .....	.2
Replace Module Board	.5 .....	.5
Replace Limit Switch	.5 .....	.5

**Gravity Vented Heaters**

Replace Gas Valve	.25 .....	.75
Replace Pilot Burner	.25 .....	.25
Replace Thermocouple	.25 .....	.50
Replace Main Burner	.25 .....	.50
Replace Combustion Chamber	.25 .....	1.25
Replace Limit Switch	.25 .....	.25

All other jobs that are not listed, contact Suburban factory Service Department for approval.

NOTE: When more than one component is defective, compute the total of both replacement times but only one set-up time.

**LIMITED WARRANTY  
SUBURBAN RECREATIONAL VEHICLE FURNACE**

**LIMITED ONE YEAR WARRANTY**

This Suburban product is warranted to the original purchaser to be free from defects in material and workmanship under normal use and maintenance for a period of one year from date of purchase whether or not actual use begins on that date. It is the responsibility of the consumer/owner to establish the warranty period. Suburban does not use warranty registration cards for its standard warranty. You are required to furnish proof of purchase date through a Bill of Sale, a cancelled check or other payment record,

Suburban will replace or repair, at its sole option, any parts that are found defective within the first year and will pay a warranty service allowance to the authorized Suburban Service Center at rates mutually agreed upon between Suburban and its authorized service centers. Replacement parts will be shipped freight prepaid within the Continental United States, Alaska and Canada.

For warranty service, the owner/ user should contact the nearest authorized Suburban Service Center, advising them of the model and serial numbers (located on the furnace) and the nature of the defect. Transportation of the unit to and from the Service Center and/or travel expenses of the Service Center to your location are the responsibility of the owner/user. A listing of authorized Service Centers is included in the owner's packet supplied with the furnace and a current listing may be obtained from Suburban.

**LIMITED FOUR YEAR WARRANTY ON HEAT EXCHANGER**

The furnace heat exchanger is further warranted to be free from defects in material and workmanship during the second through fifth year after the date of original purchase. A replacement heat exchanger will be provided under the same conditions as stated in the one year **warranty EXCEPT** no labor reimbursement will be provided.

**LIMITATION OF WARRANTIES**

ALL IMPLIED WARRANTIES (INCLUDING IMPLIED WARRANTIES OF MERCHANTABILITY) ARE HEREBY LIMITED IN DURATION TO THE PERIOD FOR WHICH EACH LIMITED WARRANTY IS GIVEN. SOME STATES DO NOT ALLOW LIMITATIONS ON HOW LONG AN IMPLIED WARRANTY LASTS SO THE ABOVE LIMITATIONS MAY NOT APPLY TO YOU. THE EXPRESSED WARRANTIES MADE IN THIS WARRANTY ARE EXCLUSIVE AND MAY NOT BE ALTERED, ENLARGED, OR CHANGED BY ANY DISTRIBUTOR, DEALER OR OTHER PERSON WHOMSOEVER.

**SUBURBAN WILL NOT BE RESPONSIBLE FOR:**

1. Normal maintenance as outlined in the installation, operating and service instructions owner's manual including cleaning of component parts; such as, orifices and burners.
2. Initial checkouts and subsequent checkouts which indicate the furnace is operating properly.
3. Damage or repairs required as a consequence of faulty or incorrect installation or application not in conformance with Suburban instructions.
4. Failure to start and/or operate due to loose or disconnected wires; water or dirt in controls, fuel lines and gas tanks; restriction or alteration of return air circulation; low voltage.

5. Routine adjustments that may be required to the thermostat, electrode and burner.
6. Costs incurred in gaining access to the furnace.
7. Parts or accessories not supplied by Suburban.
8. Damage or repairs needed as a consequence of any misapplication, abuse, unreasonable use, unauthorized alteration, improper service, improper operation or failure to provide reasonable and necessary maintenance.
9. Suburban products whose serial number has been altered, defaced or removed.
10. Suburban products installed outside the Continental U.S.A., Alaska and Canada.
11. ANY SPECIAL, INDIRECT OR CONSEQUENTIAL PROPERTY, ECONOMIC OR COMMERCIAL DAMAGE OF ANY NATURE WHATSOEVER. Some states do not allow the exclusion of incidental or consequential damages, so the above limitation may not apply to you. NO REPRESENTATIVE, DEALER OR OTHER PERSON IS AUTHORIZED TO ASSUME FOR SUBURBAN MANUFACTURING COMPANY ANY ADDITIONAL, DIFFERENT OR OTHER LIABILITY IN CONNECTION WITH THE SALE OF THIS SUBURBAN PRODUCT.

This warranty gives you specific legal rights, and you may also have other rights which vary from state to state.

**IF YOU HAVE A PRODUCT PROBLEM**

**FIRST:**

If your RV has its original furnace and is still under the RV manufacturer's warranty, follow the steps described in your RV owner's manual.

**SECOND:**

Contact a conveniently located authorized Suburban Service Center. A list of such service centers is enclosed with Suburban's Installation, Operating and Service Instructions book. Describe to them the nature of your problem, make an appointment, if necessary, and provide for delivery of the furnace to the selected service center.

**THIRD:**

Contact: Suburban Manufacturing Company  
Customer Service Department  
Post Office Box 399  
Dayton, Tennessee 37321  
Telephone: (615) 775-2131

This manual has been provided courtesy of  
My RV Works, Inc.

[www.myrvworks.com](http://www.myrvworks.com)



You can find more RV service manuals here:

[www.myrvworks.com/manuals](http://www.myrvworks.com/manuals)

Over the years of running a mobile RV repair service, having a dedicated place to access service manuals for all the different appliances and components found on RVs was something that I always had a desire to create.

I hope this resource makes your RV repairs easier, as it has mine, but please be careful and follow proper safety practices when attempting to repair your own RV.

If in doubt, please consult with a professional RV technician!



DARREN KOEPP - OWNER, MY RV WORKS, INC.

*All service manuals provided on [www.myrvworks.com](http://www.myrvworks.com) are believed to be released for distribution and/or in the public domain.*