

**ARISTON
Electro-
mechanical
Vented
Tumble Dryers**

**Models
Covered**

**Comm.
Code**

TVM63X NA

63076

***Service
Information***

SAFETY NOTES & GENERAL SERVICING ADVICE

1. This manual is NOT intended as a comprehensive repair/maintenance guide to the appliance.
2. It should ONLY be used by suitably qualified persons having technical competence applicable product knowledge and suitable tools and test equipment.
3. Servicing of electrical appliances must be undertaken with the appliance disconnected (unplugged) from the electrical supply.
4. Servicing must be preceded by Earth Continuity, Earth Resistance & Insulation Resistance checks.
5. Personal safety precautions must be taken to protect against accidents caused by sharp edges on metal and plastic parts.
6. After servicing the appliance must be rechecked for Electrical Safety. In the case of appliances which are connected to a water supply (i.e.: Washing Machines, Dishwashers & Food Centres etc.) checks must be made for leaks from seals gaskets and pipe work and rectification carried out where necessary.
7. It can be dangerous to attempt 'DIY' repairs / maintenance on complex equipment and the Company recommends that any problem with the appliance is referred to its own Service Organisation.
8. Whilst the Company has endeavoured to ensure the accuracy of the data within this publication they cannot hold themselves responsible for any inconvenience or loss occasioned by any error within.

SERIAL NUMBER / INDUSTRIAL CODE EXPLANATION

Serial Number Example

3 10 02 0895

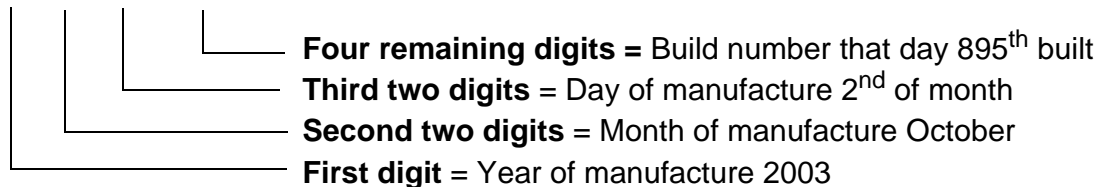

Industrial Code Example

37 24455 0010

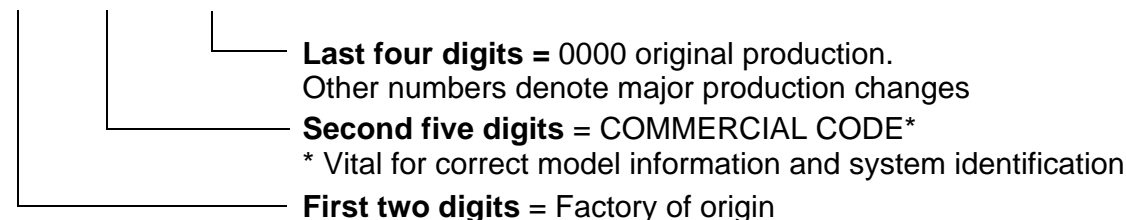

INDEX

Safety & Servicing Notes & Serial Number Information	2
Serial Number / Industrial Code Explanation	2
Technical Specifications.	4
Machine Function.	5 - 6
Console	6
Programmes.	7
Component Description	8 - 11
Timer Sequence Charts	12
Wiring Diagram	13
Dismantling Instructions.	14 - 18

TECHNICAL INFORMATION

Models Covered	TVM63XNA 63076 White
First Produced	2009
Electrical Rating	115 Volts AC 60Hz
Power Consumption	1.45 kW 12 Amps
Plug Type	USA NEMA 5.15
Cable Length	1.8 Metres
Features	Reversing - Dual Heat - 170 minutes Programme Timer, Easy Iron (crease removal) and Auto Drying options.
Energy Efficiency	C Group 100
Noise	69 dB
Country of Origin	Great Britain
Dimensions	
Height	850 mm
Width	595 mm
Depth	562 mm
Weight	35 kg (packed)
Drum	100 Litres / 6Kg Stainless Steel
Drum Speed	55 rpm Reversing
Drying Load	Dry Weight Maximum 6 Kg
Door Operation	Lever operated door catch
Heater Controls	Heat Selection Push Button out for High Heat
Heater*	1300W @ 120V
Control Thermostats*	with DBK Heater with Blasi Heater
Cycling Thermostat	120°C 106°C
One Shot	150°C 150°C
Eco Thermostats	40°C Purple Spot All thermostats are rated at 10 amps
Program Timer	Range up to 170 minutes including 7.5 minutes Cool Tumble. Two Eco Programmes and Easy Iron (crease removal) programme.
Motor	Type 353 - Capacitor run, single phase, 2 pole, induction type
Motor Speed	2800 rpm @ 115 Volts AC
Capacitor	25 uF

MACHINE FUNCTION

Cold air is drawn into the dryer cabinet interior through louvres in the cabinet base, passes through the large hole in the inner back panel adjacent to the fan and is driven through the element housing on the inner back panel.

After passing through the element windings and through holes in the drum back plate into the drum interior, the now warm air is driven through the load to the front of the drum.

A webbing seal, fixed to the inside of the inner back panel, prevents warm air being driven into the cabinet interior.

As the drum revolves, the load is tumbled through the warm air stream, that extracts moisture from the damp fabric.

The now moist and cooled air passes through the filter in the air duct on the back of the front panel, where any fluff picked up from the load is removed.

The air then travels through the front to rear air duct, leaving the dryer at the rear outlet.

If required, a vent hose may be attached to the outlet, to take exhaust air away from the dryer.

AIRFLOW DIAGRAM

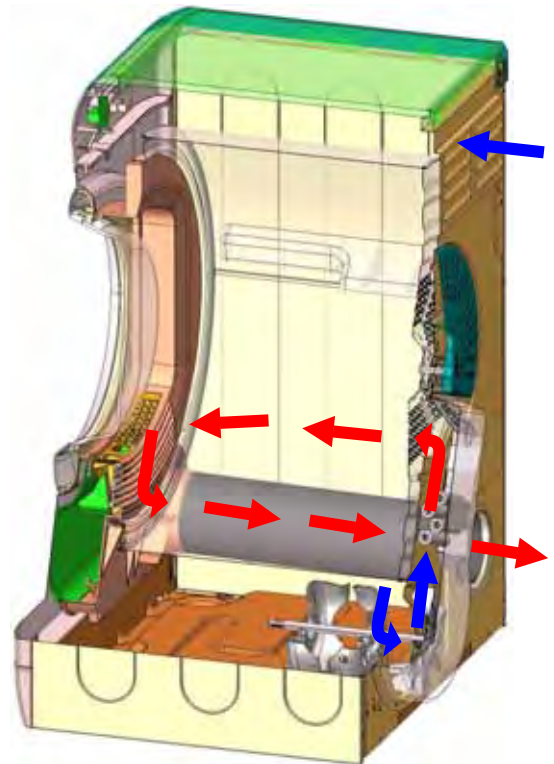

A cut-out on the element housing, cuts the electricity Live supply to the element, if the air temperature in the housing becomes too high due to a restriction in the air flow, e.g a blocked filter. The cut-out automatically resets when the air temperature drops to an acceptable level and cycles if the fault persists.

A second 'one shot' cut-out, mounted alongside the 'auto reset' cut-out, is fitted as a safety device to break the element Neutral connection, if the air temperature reaches an unsafe level due to failure of the 'auto reset' cut-out.

There are two thermostats in the front air duct when only one is in use at any one time depending on which programme is selected. These sense the exhaust temperature rise when the load becomes dry and energise the timer motor on the main timer. This allows it to advance to cool run.

AUTOMATIC DRYING

To work correctly High Heat has to be enabled and between 3 Kg to 6 Kg of Cottons dried. If smaller or delicate loads are dried using the automatic setting, erratic results will be achieved.

Automatic Drying Explanation

NOTE: - The heat switch must be set to the high position otherwise there will be no circuit to the timer motor or heater when the exhaust thermostat signals that the clothes are dry.

continued on next page.....

Sequence of Automatic Drying System

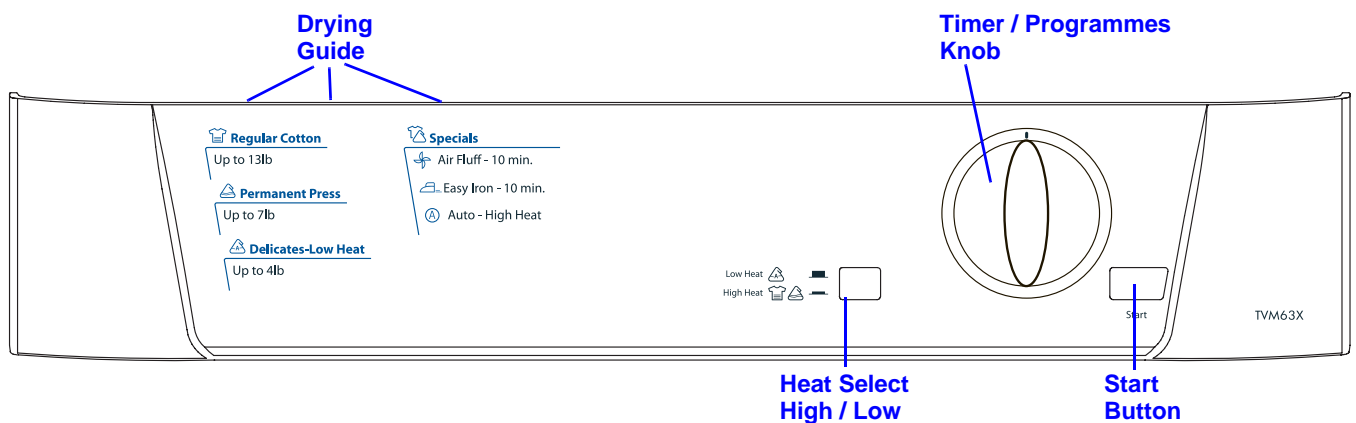

- First 20 minutes, full heat controlled by the timer. This is to pre-heat the clothes and drum before the exhaust thermostats take control.
- The timer moves to its next cam position. The timer motor is now disconnected and the dryer tumbles and heats.
- When the clothes are dry, the exhaust thermostat opens. This provides a Live supply to the timer motor. The timer moves to the next cam position.
- 5 minutes of tumbling with the lower element only. The timer moves to the next cam position.
- Finally 7.5 minutes of tumble with no heat.

CONSOLE



The **START** button begins drying a selected programme.





The **HEAT** button selects the drying temperature.

OUT: Low Heat 
IN: High Heat 

The **Drying Guide** allows the customer to consult a user friendly table of fabric types and load capacities and shows a guide of the programmes available.

The **TIMER / PROGRAMMES** knob sets the drying time or programme. Rotate it clockwise, never anti-clockwise, until the indicator is pointing to the time or programme you want to select.

PROGRAMMES

<i>Program</i>	<i>What it does...</i>	<i>How to set it..</i>	<i>Note:</i>
Timed Drying up to 170 minutes	Dries wet clothing that will be ironed, acrylic fibers or small loads (less than 2 lb / 1 kg).	1. Select required heat setting HIGH HEAT or LOW HEAT by pressing the HEAT button. 2. Position the PROGRAMS knob on the desired time. 3. Press the START button.	Consult suggested drying times (<i>see Laundry</i>).
Fabric Care  Air Fluff Phase	Heating elements turn themselves off and clothing is cooled down.	This is the final phase of all programs. Approximately 10 minutes before the finish, the knob advances automatically to the Air Fluff phase. After this the clothing is ready to be taken out.	Always allow the dryer to complete this phase.
Fabric Care  Easy Iron	Brief program (approximately 10 minutes) that softens fibers of clothing that is ready for ironing.	1. Select HIGH HEAT by pressing the HEAT button. 2. Position the PROGRAMS knob on  . 3. Press the START button.	! This is not a drying program (<i>see below</i>).
Fabric Care  Automatic Drying	Dries completely: your clothes are ready to be worn. Regular Cottons, Permanent Press.	1. Select HIGH HEAT by pressing the HEAT button. 2. Position the PROGRAMS knob on  . 3. Press the START button.	! If you select LOW HEAT, this program will not dry your clothes. For Acrylic fibers or small loads select Timed Drying.

Easy Iron Program 

Easy Iron is a short 10 minute program (8 minutes of heat followed by a 2 minute Air Fluff period) which fluffs the fibers of clothing that have been left in the same position/location for an extended period of time. The cycle relaxes the fibers and makes them easier to iron and fold.

! Easy Iron is **not a drying program** and should not be used for wet articles of clothing.

For best results:

1. Do not load more than the maximum capacity.

These numbers refer to the dry weight:

Fabric	Maximum load
Regular Cotton and Regular Cotton mix	5.5 lb / 2.5 kg
Permanent Press	4 lb / 2 kg
Denim	4 lb / 2 kg

2. Unload the dryer immediately after the end of the program, hang, fold or iron the articles and put them away. Should this not be possible, repeat the program.

The Easy Iron effect varies from one fabric to the next. It works very well on traditional fabrics like Regular Cottons or Regular Cotton mix, and less well on acrylic fibers.

COMPONENT DESCRIPTION

CONSOLE PANEL

This panel contains the user controls, which consist of a timer knob, for selecting the timed and sensed drying periods and a push switch for heat selection.

TIMER

The timer system is made up from two timers, one mounted on the console and one in the base of the machine.

Timer 1 controls the motor and heater. This has a spindle to which a knob is attached to enable the user to select the required programme. Timer 2 controls the motor reversing; this is mounted on the kickstrip. The dryer must be set to the high heat position for the Eco drying system to operate failure to do so will cause the timer to advance to cool run without drying the load.

Timer 1 - Programme Timer

Mounted on the console, the timer is used to control the motor and heating during the drying programmes. The timer incorporates a timed cycle with 170 minutes of heated drying followed by a 7.5 minute cool run.

One 'Eco' programme is incorporated with an automatic programme to provide heated drying until a thermostat operates (when the load is dry), the timer then advances to a 7.5 minute cool run.

The cam of this timer is held on the heated part of the cycle by cutting the circuit to its motor.

The dryer motor continues to be reversed by timer 2. When the load is dry, a thermostat in the front duct of the dryer operates which powers the motor of timer 1 and this allows the timer to advance to cool run. Timer 2 reverses the motor direction approximately every 2.5 minutes.

An optional crease removal programme is provided, which consists of 7.5 minutes of heat and motor followed by a cool tumble period of 2.5 minutes.

Timer 2 - Reversing Timer

Mounted on the base panel, the timer is used to control the reversal of the motor during the drying programmes. The timer reverses the motor direction every 2.5 minutes.

HEAT SWITCH

Normally open push-push switch. The switch locates into the facia moulding and it allows the user to choose high or low heat settings. By consulting the wiring diagram, it can be seen that by operating this switch, either all or half of the heater unit is selected.

For full heat switch is in the IN position and low heat in the OUT position.

High heat must be selected for the auto-drying programmes to operate, if low heat is selected the dryer will advance to cool run **without** drying the load.

DOOR

A plastic moulded chassis with a glass bowl retained by plastic mouldings.

continued on next page

DOOR INTERLOCK

Bitron Door Lock Operation

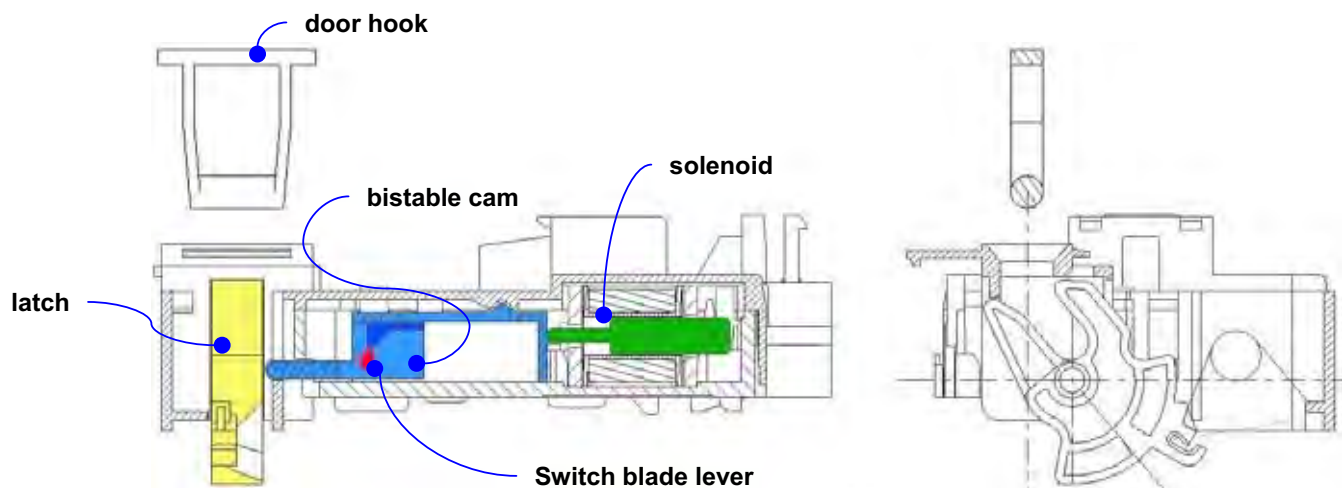

Door Open - Dryer Off

Trying to turn the machine on with the door open, the solenoid is unable to operate the bistable cam to close the contacts, because it is locked by the latch.

Door Closed - Dryer Off

Closing the door, the latch (now rotated by the door hook) allows the movement of the bistable cam, but the dryer is still OFF until the solenoid is energised.

Door Closed - Dryer On

Turning the machine on with the dryer door closed, the solenoid pushes the bistable cam (freed by the latch) allowing the closing of the contacts.

Door Opened During Drying

When the door is opened during drying, the dryer will turn off automatically by the latch in its back rotation, this pushes back the bistable cam towards the solenoid, opening the contacts.

Re-closing the door will not restart the machine until the machine is turned back on.

Safety Function

If the latch is accidentally rotated by the customer with the door open, the machine will not start. Without the latch in position, the latch rotates 30% further and sets the bistable cam in its safety position. The safety position will not allow the machine to start. The door will need to be manually repositioned to reset by a Service Engineer.

DRUM

The drum comprises of a stainless steel wrapper with a zinc-coated front and rear body and two removable plastic lifters. The rear of the drum is perforated to allow the passage of air. Fixed to the rear pressing is a support shaft, which runs in a bearing located in the rear panel of the dryer.

A drive pin and collar on the drum shaft prevents forward thrust during use. The large front flanged aperture rotates on bearing pads.

HEATER ELEMENT

The element comprises of front and rear pressings spaced apart with Mica type insulating material. Through the insulating pieces are 4 runs of coiled resistance wire supported from end to end by insulating material. High temperature insulated wires are crimped to the ends of the resistance strips to complete the circuit.

Note: Heater assemblies manufactured by Blasi and DBK are interchangeable if replaced as an assembly. Both types are used in production. The service replacement type is a DBK heater.

The thermostats are NOT interchangeable - DBK uses a 120°C, and Blasi uses a 106°C device. The correct thermostat kit MUST ALWAYS be fitted - depending on the heater fitted.

The heaters can be identified by the appearance of the indentations in the rear cover - refer to the photos below.

Blasi Heater Cover - with 2 pips



DBK Heater Cover - with 4 pips



SAFETY CUT-OUT (BLUE SPOT)

This device is a disc type thermostat set to operate at 150°C it is used as a safety device. It is positioned above the element, to the right of the cycling thermostat on the element housing. If this device fails it cannot be reset.

IF THIS DEVICE OPERATES, IT SHOULD ALWAYS BE REPLACED TOGETHER WITH THE CYCLING THERMOSTAT (see next paragraph).

CYCLING THERMOSTAT

The cycling thermostat is mounted adjacent to the safety cut-out, is designed to open at 120°C (DBK) or 106°C (Blasi). It limits the temperature of the heat entering the drum.

ECO THERMOSTATS

These are of self-resetting closed disc construction, mounted in the front air duct. They control the timer motor on timer 1. When the load is dry, the selected thermostat operates and powers the timer motor; this allows the timer to advance to cool run. The Full load thermostat (E) is designed to open at 55°C and the half load (e) is designed to open at 60°C.

MOTOR

A two pole P.S.C running at 2800 rpm with the impeller fitted to the rear end of the shaft and the drive belt running directly in grooves in the front end of the shaft. It is protected from overload by a self-resetting internal cut-out which interrupts the electrical supply to the windings.

It is used together with a capacitor that is mounted on the base of the dryer.

DRUM REAR SEAL

This unit comprises of a ring of foam with a webbing bearing face. Lubrication is applied to the drum where the webbing surface runs, to reduce noise and wear. The seal reduces air losses at the rear of the drum. The joints in the foam are sealed with glue and the joints in the webbing are stitched to further reduce air leakage.

DRUM EARTH

The earthing on the drum is achieved by the teardrop shaped bearing fixing screw.

Note: To maintain the drum earthing the correct screw must always be used.

BELT

A 9 rib belt has been used in production. The length stamped on the belt is 1860 mm. This is the fitted length. Prior to fitting, the length is approximately 1805 mm.



WIRING DIAGRAM - TVM63X NA

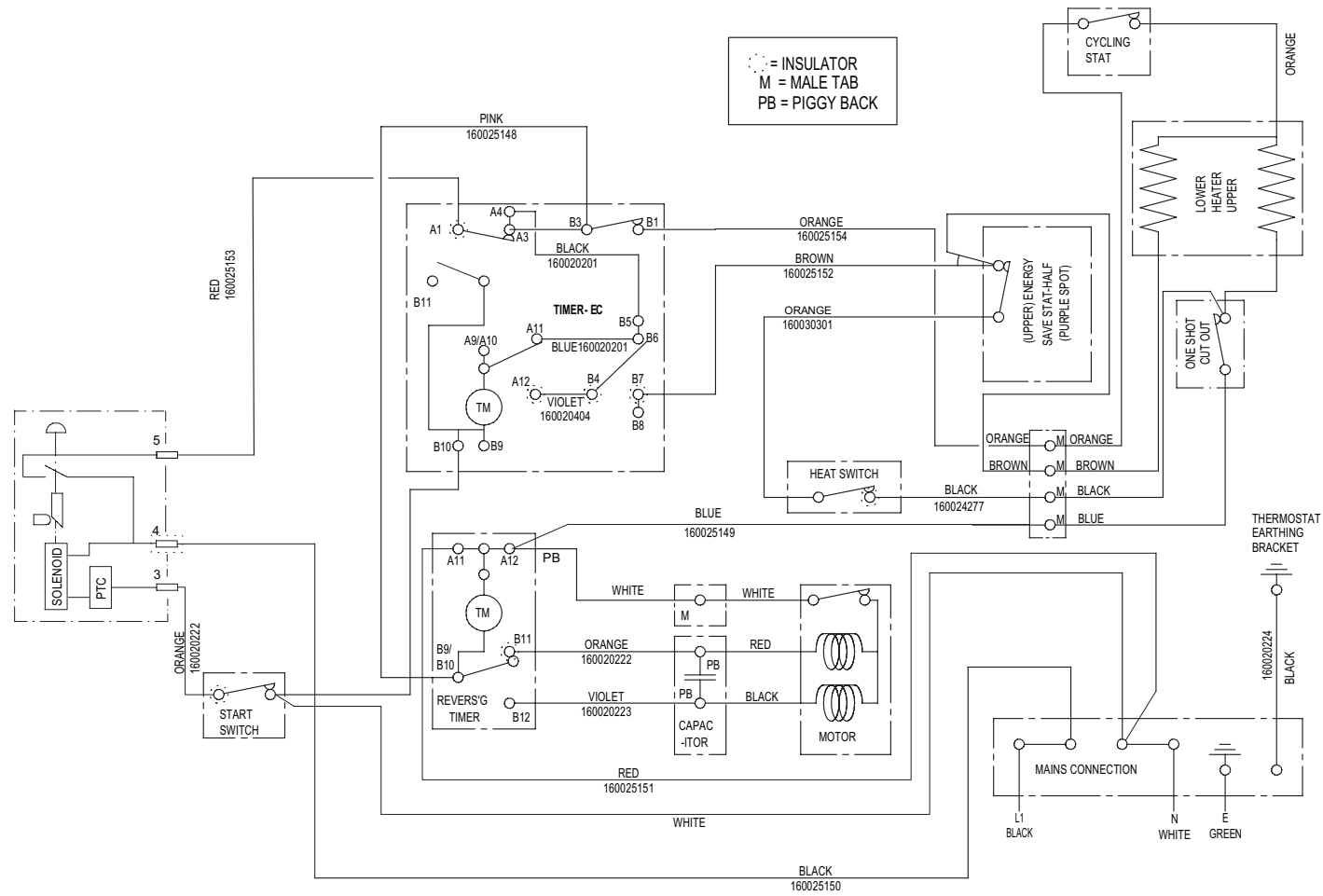

REAR VIEW OF CONNECTOR FOR HEATER

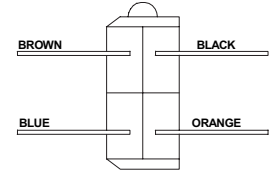

Programme Timer Wiring

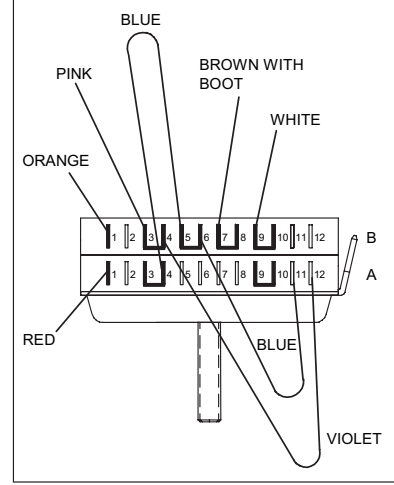

16002514202 WIRING DIAGRAM 120 VOLT NA/UL VENTING

DISMANTLING INSTRUCTIONS

SAFETY NOTES

1. Ensure that the machine is unplugged before commencing any work.
2. Beware of sharp edges on metal panels and pressed parts.

A Top Cover

1. Remove the 2 screws securing the top cover to the back panel.
2. Slide the top cover back and lift clear of the console.

B Console Panel

1. Remove the top cover as in (A).
2. Remove the 2 screws securing timer mounting plate to the console and unclip from the console.
3. Disconnect the wiring to the option switches, noting the connections.
4. Unclip the start relay from the console.
5. Remove the 2 screws securing the console to the side panels (top of console).
6. Remove the screw on the right hand side securing the front panel to the side panel.
7. Lift the locking tabs securing the console to the front panel and lift the console clear of the front panel.
8. Remove the timer knobs from the console by depressing the locking tabs.
9. Replace in reverse order.

C Programme Timer

1. Remove the top cover as in (A).
2. Remove the 2 screws securing the timer mounting plate to the console and unclip from the console.
3. Remove the screws securing the timer to the timer mounting plate.
4. Note the connections and disconnect the wiring to the timer.
5. When refitting the timer mounting plate to the console it may be easier to remove the timer knobs from the console to aid reassembly.

D Door Lock

1. Remove the top cover as in (A).
2. Remove the right hand side panel (F).
3. Disconnect the wiring.
4. Slide the switch to release it from the front panel.

E Option Switches

1. Remove the switch caps by gripping with pliers and pulling the cap off the switch shaft (care should be taken to avoid damage to the cap when removing).
2. Note the connections and disconnect the wiring from the switch.
3. Depress the locking tabs to remove the switch from the console.

F Side Panels

1. Remove the top cover as in (A).
2. Remove the plinth by pulling forward.
3. Remove the screw behind the plinth.
4. Remove the screw securing the side panel to the front panel.
5. Remove the 4 screws securing the side panel to the rear panel.
6. Pull the side panel backward to disengage from the lugs on the base panel.

G Front Panel & Air Duct

1. Remove the top cover as in (A).
2. Remove the console complete as in (B7).
3. Remove the plinth.
4. Remove the 4 screws securing the front panel to the base panel.
5. Disconnect the wiring to the air duct thermostat(s).
6. Disconnect the wiring to the door switch.
7. Remove the 2 screws securing the left hand side panel to the front panel.

I Energy Save

1. Remove the right hand side panel as in (F) above, or the front panel as in (G).
2. Disconnect the thermostat wiring and remove the 2 screws fixing the thermostat to the air duct.

J Door Switch / Interlock

1. Remove the top cover as in (A).
2. Remove the right hand side panel as in (F).
3. Disconnect the wiring to the switch.
4. Using the button removal tool Part No. C00222677 (5600127), depress the 2 plastic locating pips on the door switch (taking care not break lugs) and slide the switch towards the door seal to disengage from the front panel.

K Door Seal

1. Remove the front panel and air duct as in (G).
2. Remove the 4 screws securing the air duct to the front panel and separate the air duct from the front panel.
3. The door seal can now be removed from the front panel.
4. Replace in reverse order.

L Door

1. Open the door and remove the 4 screws securing the door assembly to the front panel.
2. Remove the complete door from the front panel.
3. Remove 1 screw securing the door latch to the door.
4. Remove the screw behind the door latch, securing the door handle to the door.
5. Remove the 6 screws securing the two halves of the door assembly.
6. The door trims can now be split giving access to the door bowl, handle and door hinges.

M Door Hinges

1. The door must be removed and split as in (L1) - (6) above.
2. Turn the door hinges inwards and slide the hinge upwards to disengage from the rear trim moulding as in Fig 1.



N Front Bearings

1. Remove the front panel as in (G).
2. Spring the fixing lug out of the open slot in the bearing mounting bracket and slide the pad along the bracket to free the other lug as illustrated.

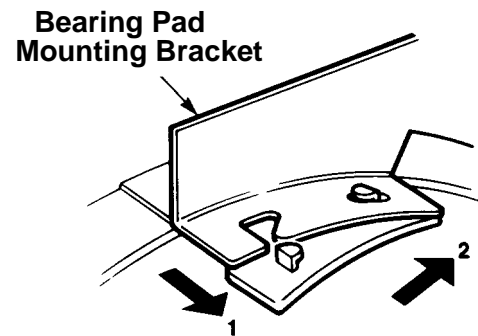

O Drive Belt Removal - if not broken

1. Remove the right hand side panel as in (E).
2. Place the end of the Special Tool, Part No. C00142716 (5600266), into the slot in the base of the dryer.



Special Belt Fitting Tool
Part No. C00142716

3. Locate the pegs of the tool into the belt and apply downward pressure to release the belt from the motor shaft.

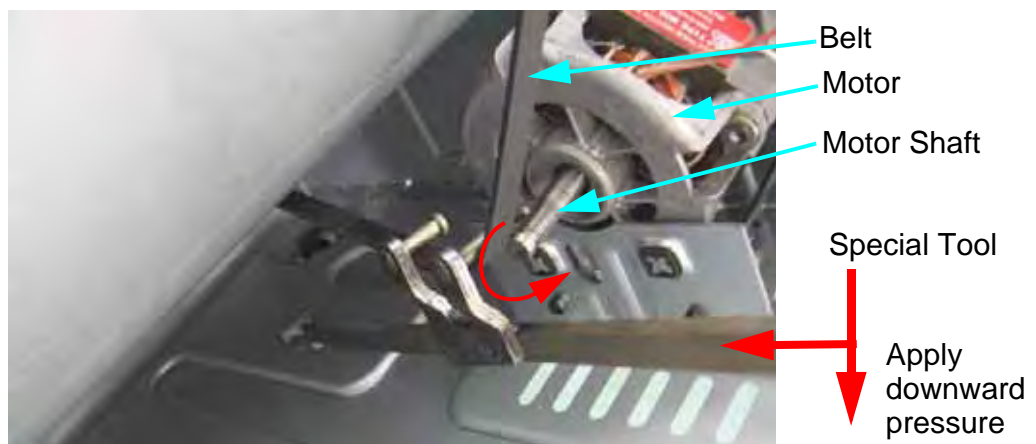

4. Release the top fixings of the front panel and ease away from the drum.
5. Slide the belt off the drum and pass between the drum front and the front panel.

Drive Belt Fitting

1. Slide the new belt onto the drum and replace the front panel.
2. Place the Special Tool, Part No. C00142716 (5600266), onto the inside edge of the new belt (cut out section of tool facing the drum).
3. Ease the special tool onto the motor shaft as far as possible.
4. Rotate the special tool in either direction to refit the belt onto the shaft.

P Capacitor

1. Remove the right hand side panel as in (F).
2. Note the wiring connections and disconnect the leads from the capacitor terminals.
3. Carefully lay the dryer on its back and remove the capacitor securing nut.

Q Drum Assembly

1. Remove the top cover as in (A)
2. Remove the console as in (B)
3. Remove the front panel as in (G).
4. Remove the right hand panel to make drum removal easier.
5. Remove the rear bearing cover - 2 screws.
6. Remove the rear bearing fixing screw.
7. Remove the drive pin and shaft collar.
Note: When reassembling, a new drive pin must be fitted.
8. Remove the rear bearing.
9. Pull the drum clear of the rear panel.

R Heating Assembly & Thermostats

1. Remove the right hand side panel as in (F).
2. Disconnect the wiring to the heater assembly (multi-pin connector).
3. Remove the bearing cover.
4. Remove the 8 screws securing the heater assembly to the rear panel.
5. Remove the 2 screws retaining the element and thermostats to the heater cover.
If replacing the thermostats both the cycling and one-shot thermostat **MUST** be replaced should either fail.
NOTE: - When refitting the heater cover, ensure the heater wiring is not trapped between the inner and outer rear panels.

S Rear Bearing

1. Remove the plastic, fan shaped bearing cover.
2. Remove the drive pin.
3. Remove the bearing fixing screw.
4. Slide the bearing off the drum shaft.
Note: To maintain the earthing of the drum, the correct bearing fixing screw **MUST** be used.

T Rear Seal

1. Remove the drum as in (Q).
2. Remove the rear seal and clean any remnants of the seal and adhesive from the inner face of the inner back panel. Fit the new seal using adhesive Part No. C00981027 (981027).

U Motor

1. Remove the right hand side panel as in (F).
2. Remove the heater cover - 8 screws.
3. Remove the 2 fans from the motor hub - 3 hex head screws.
Note: The inner and outer fans are DIFFERENT.
Ensure fans are reassembled in the correct order.
4. Note the wiring connections and disconnect the motor at the in-line connector and the capacitor.
5. Disengage the drive belt from the motor shaft as in (O2).

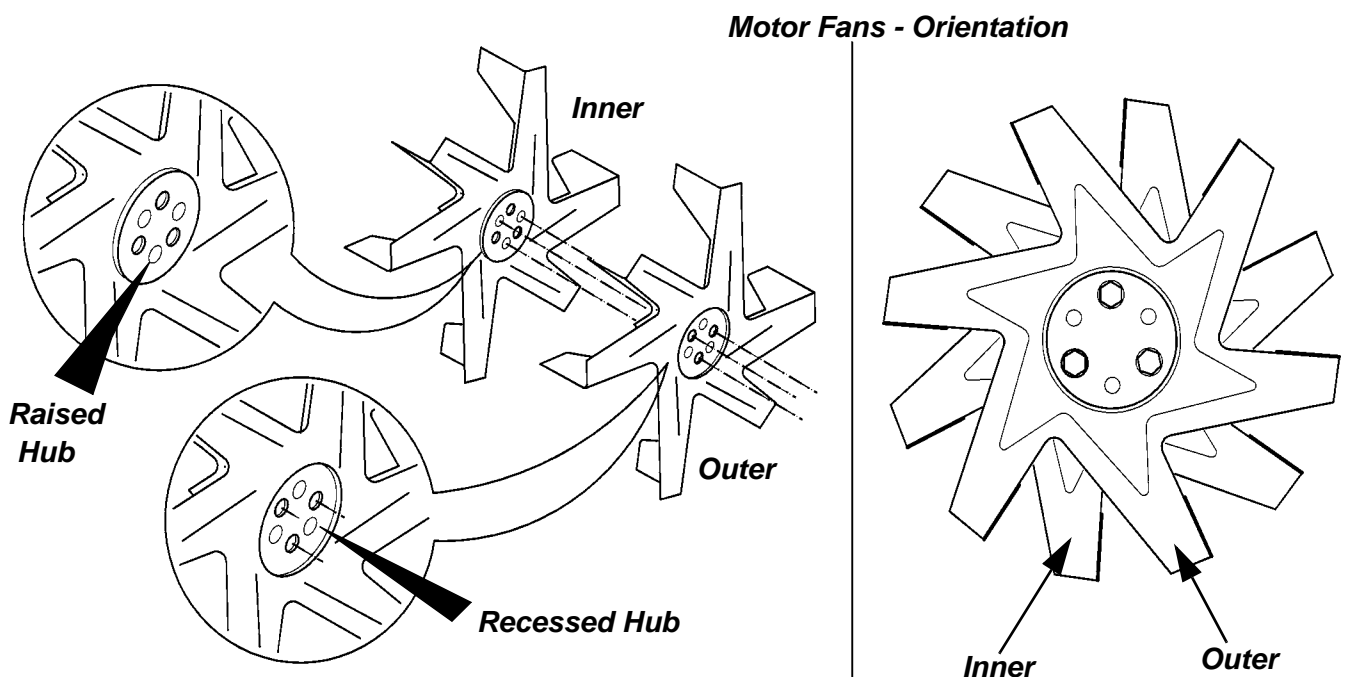

6. Remove the 3 hex head screws securing the motor to the motor cradle.
7. Remove the 2 screws securing the cradle to the base panel if necessary.
Note: When refitting the heater cover ensure that the heater wiring is not trapped between the heater cover and rear panel.

This manual has been provided courtesy of
My RV Works, Inc.

www.myrvworks.com



You can find more RV service manuals here:

www.myrvworks.com/manuals

Over the years of running a mobile RV repair service, having a dedicated place to access service manuals for all the different appliances and components found on RVs was something that I always had a desire to create.

I hope this resource makes your RV repairs easier, as it has mine, but please be careful and follow proper safety practices when attempting to repair your own RV.

If in doubt, please consult with a professional RV technician!



DARREN KOEPP - OWNER, MY RV WORKS, INC.

All service manuals provided on www.myrvworks.com are believed to be released for distribution and/or in the public domain.