



3307872.006 THERMISTOR REPLACEMENT KIT

THIS KIT CONTAINS:

- 4ea SCOTCHLOK® Wire Connectors
- 1ea Thermistor Sensor Tip
- 1ea Thermistor Connector Harness
- 1ea 3307873.012 Instructions

TOOLS REQUIRED:

- Wire Cutter
- Knife
- Pliers
- Screw Driver

GENERAL INSTRUCTIONS

- A.** This kit will allow replacement of the thermistor tip, or connector harness in Dometic refrigerators with out the need to remove the refrigerator from the RV, cooling unit from the refrigerator or pulling of the thermistor through the cabinet.
- B.** Disconnect all AC and DC power supplies at their source.

!WARNING

Disconnect all power supplies and the positive (+) terminal from the supply battery. Failure to follow this instructions may create a shock hazard.

- C.** Read and under stand all instructions before installing this kit.

!WARNING

These instructions must be read and understood before installation of this kit. This kit must be installed by a Dometic, LLC Service Center or a qualified service technician. Modification of this product can be extremely hazardous and could result in personal injury or property damage.

REPLACEMENT INSTRUCTIONS

- A.** Check out the thermistor sensor tip, connector plug for loose pins or broken wires and the thermistor cable for a shorted or open circuit. Replace only the defective portion of the thermistor assembly.

Note: A shorted or open thermistor cable requires replacement of the complete thermistor harness assembly if it is not near the connector plug or sensor tip.

B. Replacing Thermistor Tip Harness

1. Locate the thermistor sensor tip in the mounting bracket on the right hand side of the fins in the food storage area.
2. Note the position of the bracket on the fins and the thermistor in the bracket. Remove it along with the thermistor sensor tip. Pull the thermistor sensor tip out of the bracket and use wire cutters to cut the cable approximately 3 inches from the tip. See FIG.1.

FIG. 1

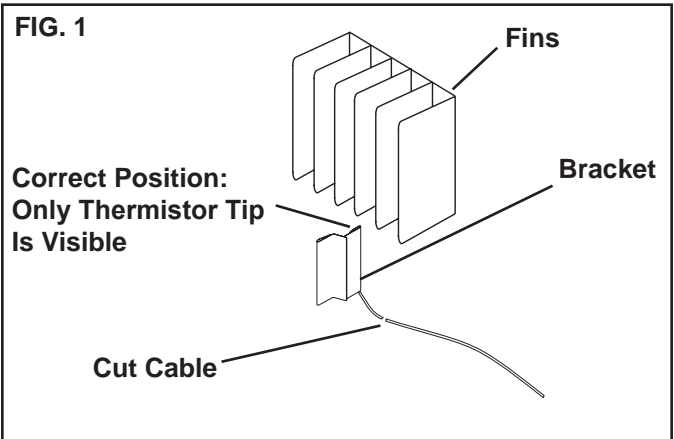

3. Separate the two wires by removing two inches of the outer jacket being careful not to nick inside wires.

Note: Do not strip the wires.

4. Insert one wire from the new thermistor tip and one wire from the main thermistor cable into the SCOTCHLOK® provided in the kit. See FIG. 2.

REVISION

Form No. 3307873.012 8/08
(Replaces 3307873.004)
(French 3307882.013)
©2008 Dometic, LLC
LaGrange, IN 46761

- Using pliers, crimp both wires at same time the in the SCOTCHLOK® splice connector. Do not over crimp. Repeat with remaining wire. See FIG. 2.

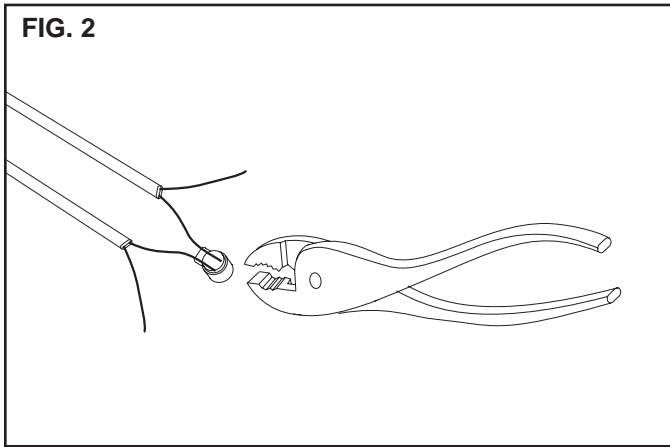

- Place the new thermistor tip in the bracket allowing just the end of the sensor to be visible (faster reaction to temperature change). See FIG. 1.
- Replace thermistor bracket on the right hand fin in the same position as it was originally.

C. Replacing Thermistor Connector Harness

- Locate the black power module on the back of the refrigerator and remove the cover.
- Unplug the thermistor two wire connector from the power module board (P2). See FIG. 3.

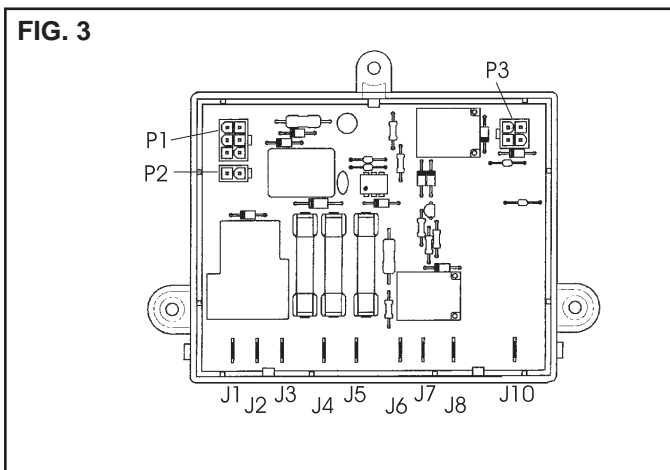

- If a thermistor adjuster (part number 2932164011 not used on all models) is installed it should be disconnected from the thermistor harness and saved to be reinstalled. See FIG. 4.

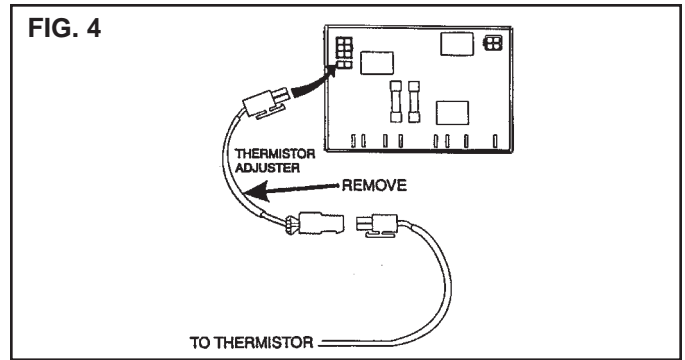

- Use wire cutters to cut the thermistor cable two inches above the connector assembly. Separate the two wires by removing two inches of the outer jacket being careful not to nick inside wires.

Note: Do not strip the wires.

- Insert one wire from the new connector harness and one wire from the main thermistor cable into the SCOTCHLOK® provided in the kit.
- Using pliers, crimp both wires at the same time, in the SCOTCHLOK® splice connector. Do not over crimp. Repeat with remaining wire. See FIG. 2.
- Plug new connector harness into power module board (if thermistor adjuster was removed it should be connected to the new connector harness and plugged into power module).
- Replace cover on power module being careful not to pinch or disconnect any leads.
- Connect the AC and DC power supplies and turn on the refrigerator and test operation.

Note: The temperatures can be adjusted a few degrees by sliding the thermistor bracket up/down on the fins and moving the thermistor sensor tip in/out of the bracket. See FIG. 1.

This manual has been provided courtesy of
My RV Works, Inc.

www.myrvworks.com



You can find more RV service manuals here:

www.myrvworks.com/manuals

Over the years of running a mobile RV repair service, having a dedicated place to access service manuals for all the different appliances and components found on RVs was something that I always had a desire to create.

I hope this resource makes your RV repairs easier, as it has mine, but please be careful and follow proper safety practices when attempting to repair your own RV.

If in doubt, please consult with a professional RV technician!



DARREN KOEPP - OWNER, MY RV WORKS, INC.

All service manuals provided on www.myrvworks.com are believed to be released for distribution and/or in the public domain.