

USA
SERVICE OFFICE
Dometic Corporation
509 South Poplar Street
Lagrange, IN 46761
260-463-4858

CANADA
Dometic Distribution
866 Langs Drive
Cambridge, Ontario
CANADA N3H 2N7
519-653-4390

**For Service Center
Assistance Call:**
800-544-4881

3308741.002 2-Way 3308742.000 3-Way Universal Power Module Kit Installation Instructions

3308741.002 2-Way Kit Includes:

- (1) 3850415013 Power Module Assembly
- (1) 3308727.001 Wiring Diagram
- (1) 3308770.001 Wire, Black
- (1) 3308772.007 Wire Harness, 2-way
- (1) 3308774.003 Screw, #4 x 1/2"
PRH Self Tapping
- (1) 3308740.004 Installation Instructions

3308742.000 3-Way Kit Includes:

- (1) 3850415013 Power Module Assembly
- (1) 3308727.001 Wiring Diagram
- (1) 3308769.003 Wire Connector
- (1) 3308770.001 Wire, Black
- (1) 3308771.009 Wire, Red
- (1) 3308773.005 Wire Harness, 3-Way
- (1) 3308774.003 Screw, #4 x 1/2"
PRH Self Tapping
- (1) 2930385006 Relay, 12VDC
- (1) 3308740.004 Installation Instructions

SERVICE INSTRUCTIONS

**Americana
AMES/AES 2-Way
AMES/AES 3-Way**

SAFETY INSTRUCTIONS

This manual has safety information and instructions to help users eliminate or reduce the risk of accidents and injuries.

RECOGNIZE SAFETY INFORMATION



This is the safety-alert symbol. When you see this symbol in this manual, be alert to the potential for personal injury.

Follow recommended precautions and safe operating instructions.

UNDERSTAND SIGNAL WORDS

A signal word, **WARNING OR CAUTION** is used with the safety-alert symbol. They give the level of risk for potential injury.

! WARNING Indicates a potentially hazardous situation which, if not avoided, could result in death or serious injury.

! CAUTION Indicates a potentially hazardous situation which, if not avoided may result in minor or moderate injury.

CAUTION When used without the safety alert symbol indicates, a potentially hazardous situation which, if not avoided may result in property damage.

Read and follow all safety information and instructions.

GENERAL INSTRUCTIONS

This Universal Power Module Kit is a direct replacement for all current refrigerator control boards, namely 2 & 3 Way, and Americana. There is no need for a new Eyebrow Display; the universal board self-recognizes which display type it is connected to therefore the eyebrow does not have to be replaced. The installer must strictly adhere to the installation procedure below, paying specific attention to tabs J1 to J4; if not wired correctly damage to the board will result.

! WARNING

These instructions must be read and understood before installation of this kit. This kit must be installed by a Dometic Service Center or a qualified service technician. Modification of this product can be extremely hazardous and could result in personal injury or property damage.

REPLACEMENT INSTRUCTIONS

A. 3308741.002 Americana and 2-Way AMES/AES Refrigerators Universal Power Module Kit

1. Disconnect all wires and harnesses from circuit board.
2. Remove old circuit board.
3. Disconnect P3 harness from gas valve solenoid, ignitor, and ground terminal.
4. Replace P3 harness with new version. Connect white wire to one side of the gas valve solenoid, and the yellow wire to the other side. The secondary yellow wire spliced to the solenoid wire connects to the (+) of the ignitor.
5. Unscrew chassis ground screw from backplate and attach black ground wire; reinsert ground screw and firmly retighten.
6. Connect the red (+) 12VDC wire to J1 terminal.
7. Connect the Light/Heating Cable blue wire(s) to either J2 or J3. In older refrigerators these two wires are spliced together to one tab. In the future they will be 2 separate wires.
8. Connect the longer of the two black Thermocouple wires to J4 terminal.
9. Connect the positive (+) black 120 VAC Line to J5 terminal.
10. Connect the neutral (-) white 120 VAC wire to J6 terminal.
11. Connect AC Heater element wires to J7 and J8 terminals.
12. Connect remaining black Thermocouple wire to J10 terminal. This lead from the thermocouple is normally the shortest of the two.
13. Connect new black ground wire from backplate to J9 terminal.

14. Connect P1, P2, and P3 connectors to the appropriate terminals on circuit board.
15. Snap cover into place carefully so as to avoid pinching any wiring. Secure cover to backplate with #4 x 1/2" self-tapping screw provided.
16. Place new wiring diagram decal over the old one.
17. Installation of this Universal Power Module Kit is now complete

B. 3308742.000 3-Way AES/AMES Refrigerator Universal Power Module Kit

1. Disconnect all wires and harnesses from circuit board.
2. Remove old circuit board.
3. Disconnect P3 harness from gas valve solenoid, ignitor, and ground terminal.
4. Replace P3 harness with new version. Connect white wire to one side of the gas valve solenoid, and the yellow wire to the other side. The secondary yellow wire spliced to the solenoid wire connects to the (+) of the ignitor.
5. Unscrew chassis ground screw from backplate and attach black ground wire; reinsert ground screw and firmly retighten.
6. Install relay by utilizing the screw hole (and screw) used previously on the older style circuit board to attach the cover to the backplate. Mount relay with the connection terminals pointing to the right, and mounting hole to the left.
7. Connect the two Blue wires from the P3 harness to terminals 85 and 86 on the relay. See FIG. 1.

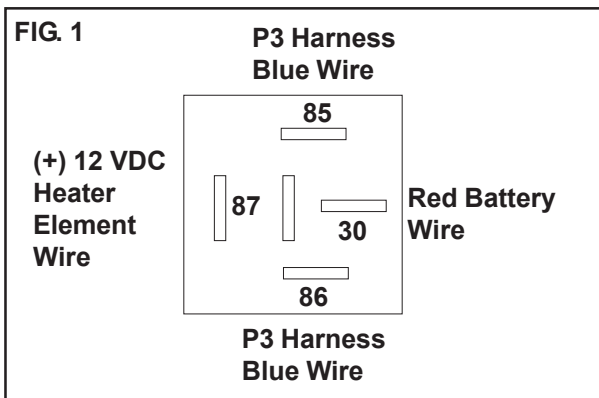

8. Using the tab connector end of the single Red wire connect it to terminal 30 or the relay. The opposite end will tap into the J1 battery input wire using the SCOTCHLOC 562 as shown in Fig. 2. Follow instructions in step 9 to make this connection.
9. Red wire line tap connection.
 - a. Disconnect battery input wire from terminal block.
 - b. Place J1 connector tab input wire into outer run channel of SCOTCHLOK. See FIG. 2.
 - c. Insert red tap wire from terminal 30 of relay completely up to inner stop channel.
 - d. Clamp pliers onto top of u-contact and bottom of case; make connection by driving the u-contact down flush with top of the plastic insulator.

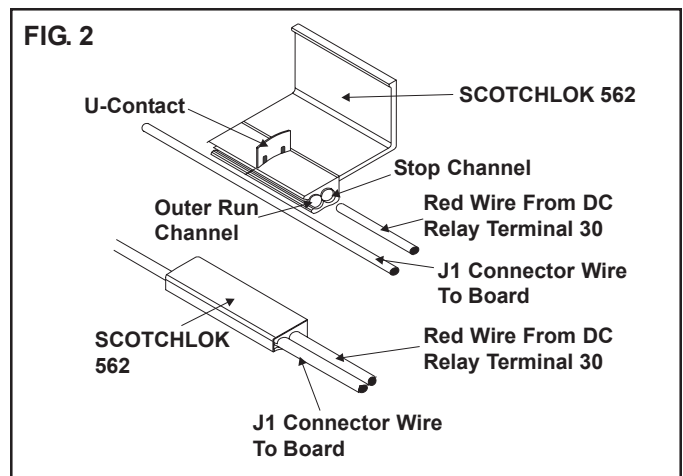

- e. Close hinged top cover until latched.
- f. Reconnect battery wire to terminal block.
10. Connect the 12V (+) lead from the DC heater to terminal 87 of the relay.
11. Connect the 12V (-) lead from the DC heater to the ground terminal strip.
12. Connect the red (+) 12VDC wire to J1 terminal.
13. Connect the Light/Heating Cable blue wire(s) to either J2 or J3 terminals on the board. In older refrigerators these two wires are spliced together to one tab. In the future they will be two separate wires.
14. Connect the longer of the two black Thermocouple wires to J4 terminal on the board.
15. Connect positive (+) black 120 VAC Line to J5 terminal.
16. Connect the neutral (-) white 120 VAC wire to J6 terminal.
17. Connect the AC Heater element wires to J7 and J8 terminals.
18. Connect remaining black Thermocouple wire to J10 terminal. This lead from the Thermocouple is normally the shortest of the two.
19. Connect new black ground wire from backplate to J9 terminal.
20. Connect P1, P2, and P3 connectors to the appropriate terminals on the circuit board.
21. Snap cover into place carefully so as to avoid pinching any wiring. Secure cover to backplate with #4 x 1/2" self-tapping screw provided.
22. Place new wiring diagram decal over the old one.
23. Installation of this Universal Power Module Kit is now complete.

Important: When this Universal Power Module Kit is connected to an AES display, the DC threshold level detection is no longer available; board will continue to operate in DC mode, even though voltage level is lower than normal. The 12VDC mode should only be used while traveling down the road so the battery is constantly being charged otherwise the battery could be drained if unattended for a long period of time. If 120VAC is not available, use Gas mode. The RV owner must be notified of these changes.

WIRING DIAGRAM

3308727.001

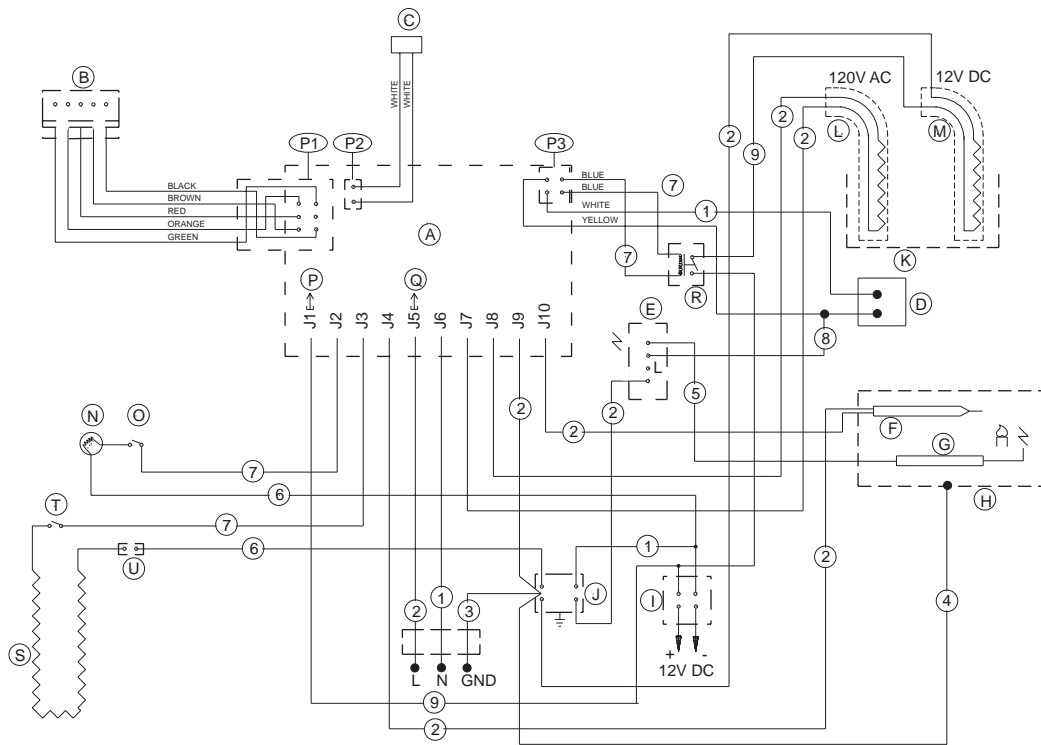

- (A) — CIRCUIT BOARD POWER MODULE
- (B) — CIRCUIT BOARD DISPLAY
- (C) — THERMISTOR
- (D) — GAS VALVE
- (E) — REIGNITER
- (F) — THERMOCOUPLE
- (G) — ELECTRODE
- (H) — RETAINER FOR BURNER
- (I) — TERMINAL BLOCK
- (J) — GROUND TERMINAL STRIP
- (K) — ABSORPTION UNIT
- (L) — HEATER 120V AC
- (M) — HEATER 12V DC
- (N) — LIGHT
- (O) — SWITCH
- (P) — FUSE 3A
- (Q) — FUSE 5A
- (R) — DC HEATER RELAY
- (S) — HEATING CABLE
- (T) — SWITCH
- (U) — TERMINAL BLOCK

- (1) — WHITE
- (2) — BLACK
- (3) — GREEN
- (4) — GREEN/YELLOW
- (5) — GREY
- (6) — BROWN
- (7) — BLUE
- (8) — YELLOW
- (9) — RED

This manual has been provided courtesy of
My RV Works, Inc.

www.myrvworks.com



You can find more RV service manuals here:

www.myrvworks.com/manuals

Over the years of running a mobile RV repair service, having a dedicated place to access service manuals for all the different appliances and components found on RVs was something that I always had a desire to create.

I hope this resource makes your RV repairs easier, as it has mine, but please be careful and follow proper safety practices when attempting to repair your own RV.

If in doubt, please consult with a professional RV technician!



DARREN KOEPP - OWNER, MY RV WORKS, INC.

All service manuals provided on www.myrvworks.com are believed to be released for distribution and/or in the public domain.