



RECORD THIS UNIT INFORMATION FOR FUTURE REFERENCE:	
Model Number	_____
Serial Number	_____
Date Purchased	_____

**A&E SUNCHASER II TC
Patio Awning
USER'S GUIDE
For
8275000.409# Series Sunchaser II TC Hardware
Used With
812(XX)(XX).40(X)# & 812(XX)44.(XXX)#
Model Series Awnings**

USA
SERVICE OFFICE
Dometic Corporation
2320 Industrial Parkway
Elkhart, IN 46516
574-294-2511

CANADA
Dometic Corporation
46 Zatonski, Unit 3
Brantford, ON N3T 5L8
CANADA
519-720-9578

For Service Center Assistance Call:
800-544-4881

⚠ WARNING

This manual must be read and understood before installation, adjustment, service, or maintenance is performed. This unit must be installed by a qualified service technician. Modification of this product can be extremely hazardous and could result in personal injury or property damage.

⚠ AVERTISSEMENT

Lire et comprendre ce manuel avant de procéder à l'installation, à des réglages, de l'entretien ou des réparations. L'installation de cet appareil doit être effectuée par un réparateur qualifié. Toute modification de cet appareil peut être extrêmement dangereuse et entraîner des blessures ou dommages matériels.

USER'S GUIDE

**8275000.409(#)
SERIES
HARDWARE**

Important: These Instructions must stay with unit. Owner read carefully.

Quick Reference Guide

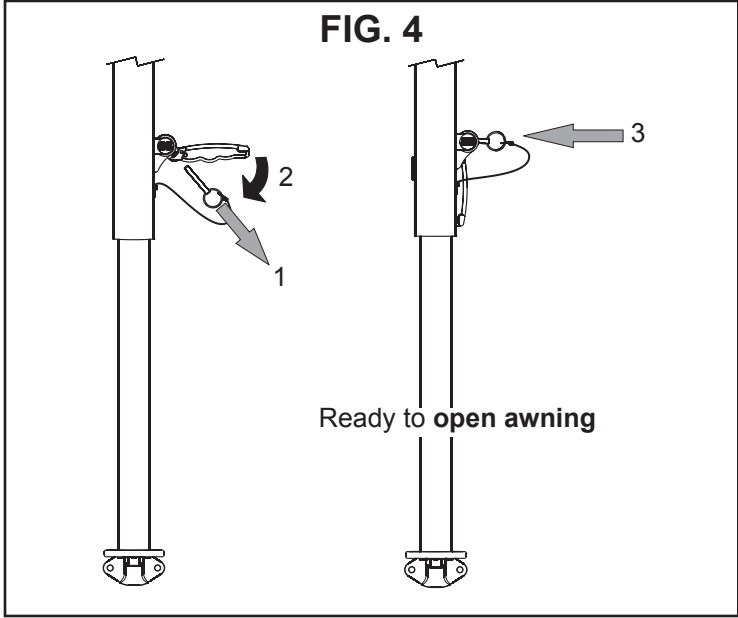
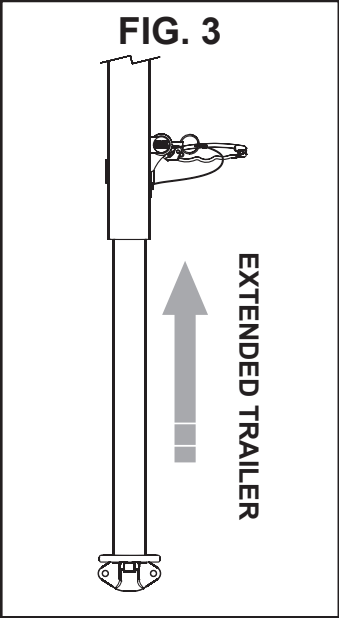
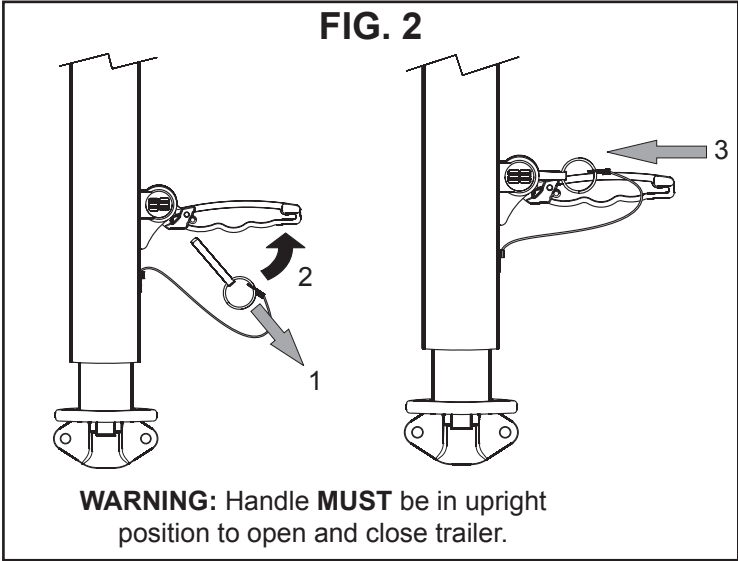
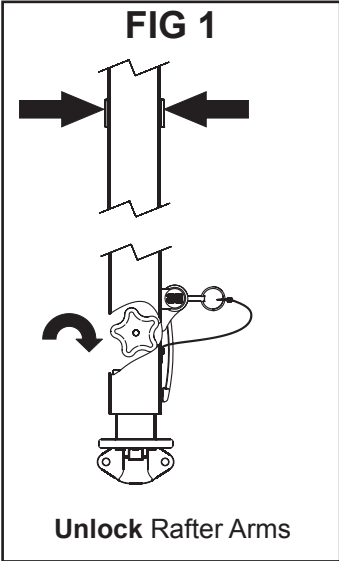

SAFETY INSTRUCTIONS

This manual has safety information and instructions to help users eliminate or reduce the risk of accidents and injuries.

RECOGNIZE SAFETY INFORMATION



This is the safety-alert symbol. When you see this symbol in this manual, be alert to the potential for personal injury.

Follow recommended precautions and safe operating instructions.

UNDERSTAND SIGNAL WORDS

A signal word, **WARNING OR CAUTION** is used with the safety-alert symbol. They give the level of risk for potential injury.

WARNING indicates a potentially hazardous situation which, if not avoided, could result in death or serious injury.

CAUTION indicates a potentially hazardous situation which, if not avoided, may result in minor or moderate injury.

CAUTION used without the safety alert symbol indicates, a potentially hazardous situation which, if not avoided, may result in property damage.

Read and follow all safety information and instructions.

A. TO OPEN AWNING

1. Before extending the trailer, pinch lock to release rafter from main arm assembly and loosen rafter knobs. See FIG. 1.
2. Pull the clevis pin out of the lift handle assembly, lift the handle away from the arm and into its horizontal position, and re-install the clevis pin. This should secure the handle in the disengaged (horizontal) position. Repeat on opposite side. See FIG 2.
3. Extend the trailer (consult the User's Manual provided with your vehicle). See FIG. 3.
4. Once the trailer is fully extended, pull the clevis pin out of the lift handle assembly, lower the handle towards the arm into its engaged (vertical) position, and re-install the clevis pin. Repeat on opposite side. See FIG 4.
5. Using both hands, hold on to the bottom edge of the arm and gently push up until you feel the lift handle assembly engage the nearest hole in the adjustable arm.
6. Use the pull rod to hook and pull down lock lever. See FIG. 5.

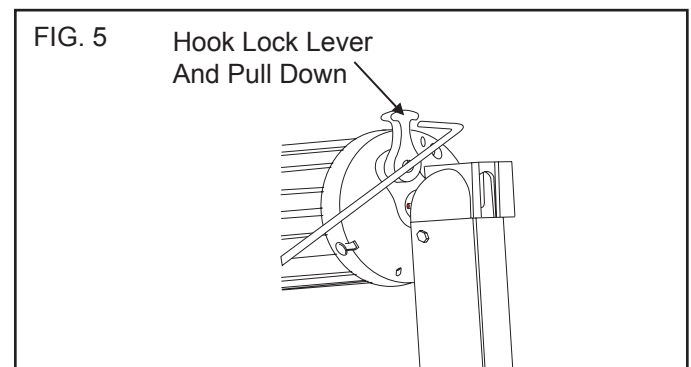

7. Hook the pull rod in the loop on the pull strap and pull awning all the way out. See FIG. 6.

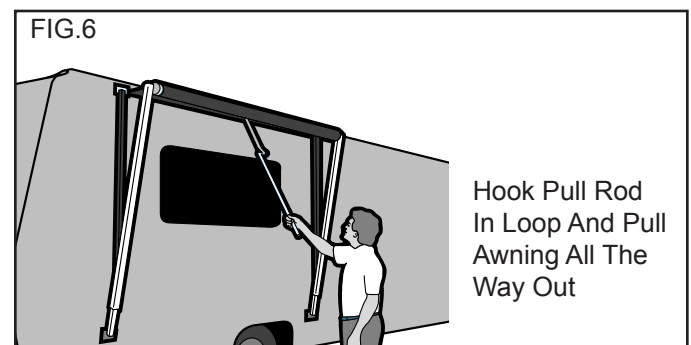

8. Swing rafter out and towards the roller tube end cap. Hook the rafter claw onto torsion rod inside of the end cap. See FIG. 7.

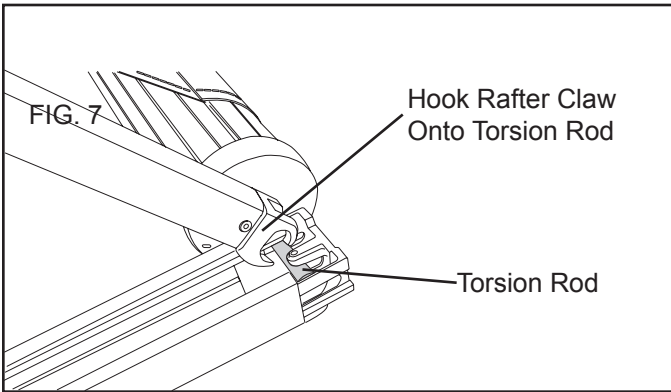

9. While stretching fabric taut, tighten knob. Repeat on opposite side. The knob is designed with a groove. If the height of the knob makes it difficult to tighten, you may insert the end of the 23" wire handle (supplied) in the groove and tighten the knob by turning the handle. See FIG. 8.

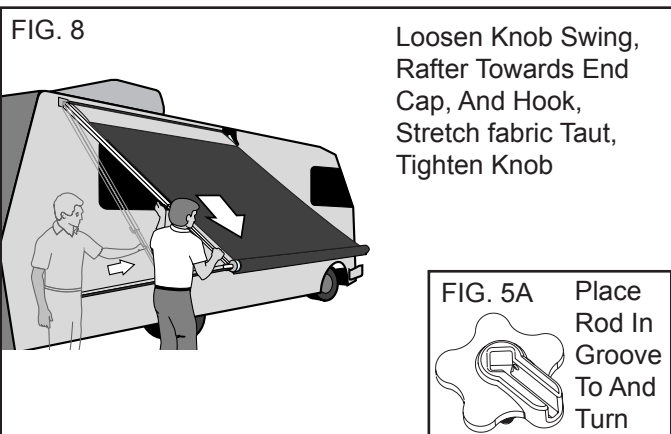

10. Slide pull strap to the right hand end of the roller tube and wrap around arm. See FIG. 9.

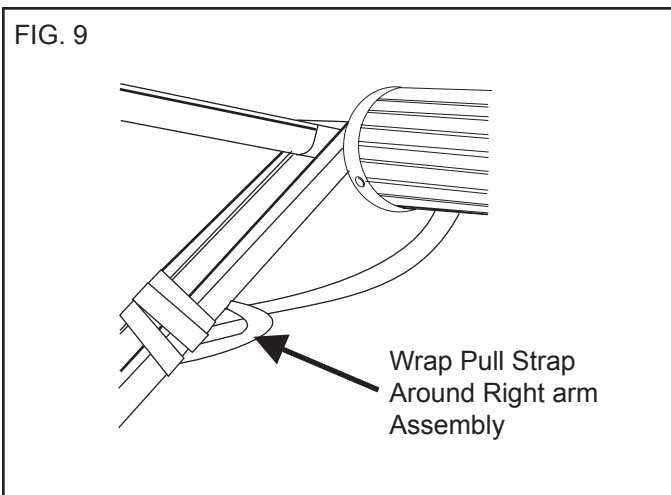

11. Press the release lever on the lower mounting bracket and pull the arm away. Snap the patio foot into the higher mounting bracket on the coach side wall. Repeat on opposite side. See FIG. 14.
12. Pull the clevis pin out of the lift handle assembly. While holding arm, pull up on the lift handle to release and lift awning to desired height. Release handle and allow the lock button to engage into a hole in the adjustable arm. See FIG. 10.

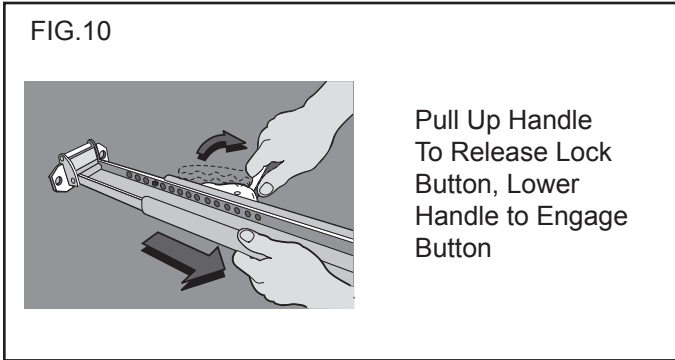

13. To place the awning in the carport position, press the release lever on the bottom mounting bracket and pull the arm away. Move to a vertical position, and secure in place with stakes. Rise to desired height. Repeat on opposite end. See FIG. 11.

⚠ CAUTION

Lifting Hazard: Use extreme caution when lifting arm off bottom mounting bracket. If not controlled Fabric Roller Tube Assembly could cause back injury and or damage to RV and Awning

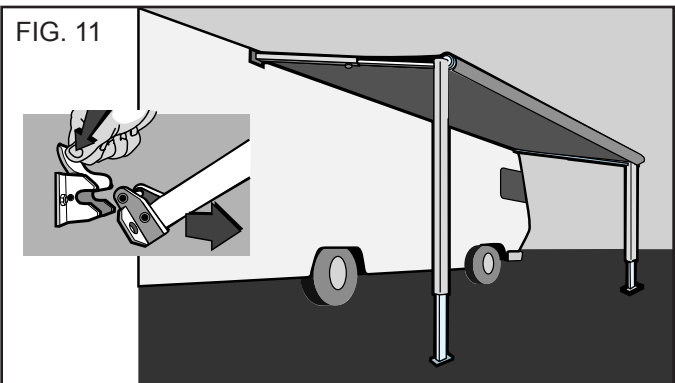

Important: Never leave the roller tube level with the awning rail, adjust both arms of the Universal Hardware 7 to 8 adjustable arm holes below awning rail (fabric slope approximately 10 degrees). Sunchaser hardware should be in the water shed position. See FIG. 12.

⚠ WARNING

Water Pooling Hazard:
Whenever heavy rain is expected the awning must be placed in the storage position. Pooling of water on top of the awning fabric, will make the awning unstable causing the arms and roller tube to bend or collapse. Never release lift handle locks with water pooled on canopy. This will result in personal injury, death and damages to the awning and/or recreational vehicle.

14. If light rains are expected, place the awning in the water shed position. See FIG 12.

FIG.12

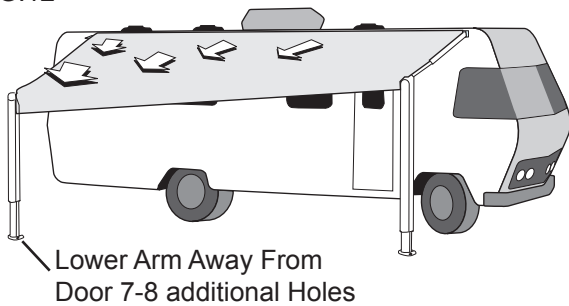

Note: Sunchaser Model Series 8275000 hardware is not equipped with water dump feature and one arm must be an additional 7-8 holes (fabric slope approximate 10 degrees) lower than the other arm before it is in the water-dump configuration. See FIG. 9.

Note: Never leave an open awning unattended.

B. TO CLOSE AWNING

1. When in the carport position, remove stakes from the ground and unwrap pull strap. Grasp the upper arm with both hands, and raise lift handle to release lock button. Lower arms to their shortest position against the stops. See FIG. 13.

FIG.13

Raise Handle To Release Lock Button, Lower To Shortest Position

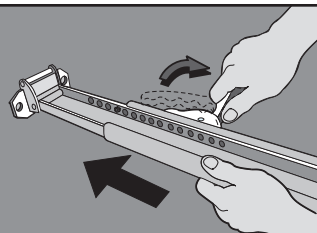

2. Make sure the lock lever on the awning right hand torsion is in the roll down position.

⚠ WARNING

Pinch hazard: Always check to ensure the lock lever is in the roll down position. Failure to place Lock Lever in the roll down position will allow the awning to roll up unexpectedly and quickly resulting in pinching of hand, arm and/or damage to awning.

3. Snap the patio foot into the bottom mounting bracket on the coach side wall. Repeat on opposite side. See FIG. 14.

FIG.14

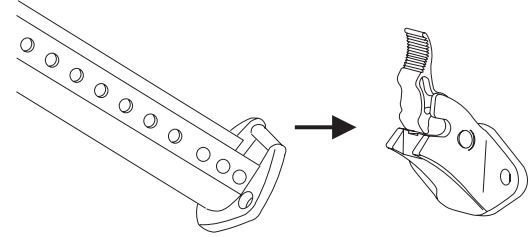

Snap Patio Foot Into Bracket

4. Loosen knob and unhook the rafter end from the torsion top casting.
5. For Sunchaser models, swing rafters back against side wall resting on top of the patio foot in the arm assembly. Repeat for opposite side.
6. Grasp pull strap in left hand and move towards the center of the roller tube. Hook the pull rod in the pull strap loop. See FIG. 15.

Important: Do Not release pull strap. Awning is under spring tension and it could roll up unexpectedly and quickly against the vehicle side.

FIG. 15

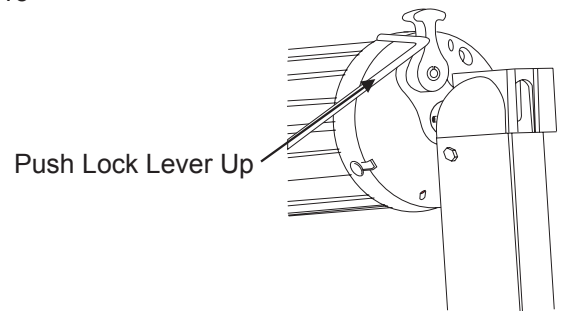

7. While holding the pull strap, push the lock lever on the right awning end cap to the roll up position.
8. Control the speed of the awning and allow it to roll up, while moving the pull strap diagonally to the left or right to prevent it from bunching up.

9. Pull the clevis pin out of the lift handle assembly, lift the handle away from the arm and into its horizontal position, and re-install the clevis pin. This should secure the handle in the disengaged (horizontal) position. Repeat on opposite side. See FIG. 2
 10. Making sure the lift handle assemblies are disengaged and the rafter knobs are loose, lower the trailer (consult the User's Manual provided with your vehicle).
 11. Once the trailer is fully lowered, pull the clevis pin out of the lift handle assembly, lower the handle towards the arm into its engaged (vertical) position, and re-install the clevis pin. Repeat on opposite side.
 12. Using both hands, hold on to the bottom edge of the arm and gently push up until you feel the lift handle assembly engage the nearest hole in the adjustable arm.
 13. Replace the pin in the lift handle assembly and squeeze the rafter into the main arm until a click is heard. This will indicate it is locked in place. Tighten knobs on both sides to secure in place.
- b. Avoid touching the underside of the 9000 canopy when it is wet. To do so will break the surface tension of the water and encourage seepage through the fabric.
 - c. Because woven acrylic is of a much lighter weight than vinyl, shifting may occur if the awning and pull strap are not centrally aligned with the fabric roller tube while the awning is being rolled up. If necessary, roll the awning out and adjust the alignment.
7. When To Get More Help:
 - a. If malfunctions occur that cannot be corrected by reviewing this user's guide, contact a qualified Dometic service technician.

Note: A slight "travel line" may appear where the door roller contacts the awning fabric. This is considered normal and does not affect the integrity of the awning.

C. CARE AND USE

1. Whenever the awning is wet while rolled up, as soon as conditions allow, roll it out and let it dry before rolling it up again. This will help prevent mildew and rotting.
2. Mildew does not form on the fabric itself, but on the accumulated dust, dirt and grime. Periodically clean vinyl or woven acrylic. Refer to cleaning instructions below for fabric care.
3. Always make sure the awning is extended high enough before opening the entry door.
4. Apply silicone spray lubricant as needed to keep the awning's moving parts operating smoothly. For ease of operation on hardware, rub candle wax on all sliding surfaces.
5. A&E 8500 and SUNCHASER:
 - a. Abrasion, weather and long hours in the sun are vinyl's worst enemies. To avoid these problems, you will need to keep your awning fabric clean. Use a mixture of 1/4 cup dish soap, 1/4 cup bleach and five gallons of fresh water. Soap the open awning with this mixture, then roll it up and let stand for five minutes. Rolling up of the awning will apply the mixture to the underside of the fabric. Unroll the awning and hose off the top and bottom with clean water. Repeat if necessary and allow to completely dry.
6. A&E 9000 :
 - a. In addition to its beauty and soft translucence, woven acrylic fabric offers the advantages of strength and breathable. It is water repellent; but because it is a woven cloth, it is not water proof. To keep your acrylic awning clean, simply hose it off occasionally and let it dry. Do Not Scrub.

This manual has been provided courtesy of
My RV Works, Inc.

www.myrvworks.com



You can find more RV service manuals here:

www.myrvworks.com/manuals

Over the years of running a mobile RV repair service, having a dedicated place to access service manuals for all the different appliances and components found on RVs was something that I always had a desire to create.

I hope this resource makes your RV repairs easier, as it has mine, but please be careful and follow proper safety practices when attempting to repair your own RV.

If in doubt, please consult with a professional RV technician!



DARREN KOEPP - OWNER, MY RV WORKS, INC.

All service manuals provided on www.myrvworks.com are believed to be released for distribution and/or in the public domain.