



# SERVICE MANUAL

**FOR WINNEBAGO MOTORIZED VEHICLES  
310 OR 610 SERIES LEVELING SYSTEMS  
SPACEMAKER® ROOM EXTENSION SYSTEMS**

***FEATURING:***

*Single Cylinder "Guided" Room Extension  
Dual Cylinder Room Extension (With Synchronizing Cylinder)  
"Level Out" Room Extension (With Synchronizing Cylinder)*

**HWH CORPORATION**  
(On I-80, Exit 267 South)  
2096 Moscow Road | Moscow, Iowa 52760  
Ph: 800/321-3494 (or) 563/724-3396 | Fax: 563/724-3408  
[www.hwh.com](http://www.hwh.com)

**ML23521/MI91.0020  
05MAY04**

# SECTION 1

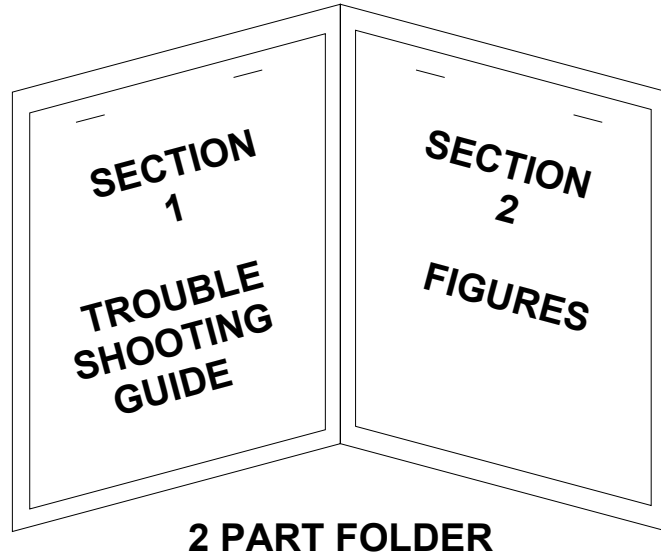

## HOW TO USE MANUAL

**IMPORTANT:** This manual will not work if diagnosing a problem on a coach with a four cylinder room extension.

**NOTE:** This manual will work for systems with single cylinder room extensions also. The only difference is the exclusion of synchronizing cylinder problems.

This manual is written in two sections. Section 1 is the Trouble Shooting Guide. Section 2 is the figures. Begin diagnosis of the system with Section 1, the Trouble Shooting Guide. The Trouble Shooting Guide is broken into 3 columns, Problem, Solutions and Figures. Under Problems, find the symptom you have encountered. The testing and repair for that problem is in the Solution (center) column. Diagrams for a particular Problem and Solution are in the Figures (right hand) column. This column will direct you to the proper figure in Section 2, Figures, for a more detailed view.

Before beginning your repair, it is **IMPORTANT** to read the **CAUTIONS** and **NOTES AND CHECKS** in the first section, **TROUBLE SHOOTING GUIDE**. In many cases this will save time and mistakes when trouble shooting a system.

This Repair Manual is offered as a guide only. It is impossible to anticipate every problem or combination of problems. For any problems encountered that are not addressed in this manual, contact HWH Corporation for assistance. (800-321-3494)

The room should be fully retracted before Trouble Shooting the system. If the room will not retract, use the manual retract procedure on pages MP35.9490 and MP35.952D.

**Make sure all room locks and the manual retract winch are not engaged before trouble shooting the system.**

**PROCEED WITH TROUBLE SHOOTING GUIDE**



# TROUBLE SHOOTING

## WARNING!

**BLOCK FRAME AND TIRES SECURELY BEFORE CRAWLING UNDER VEHICLE. DO NOT USE THE LEVELING JACKS OR AIR SUSPENSION TO SUPPORT VEHICLE WHILE UNDER VEHICLE OR CHANGING TIRES. VEHICLE MAY DROP AND OR MOVE FORWARD OR BACKWARD WITHOUT WARNING CAUSING INJURY OR DEATH.**

**KEEP PEOPLE AND OBJECTS CLEAR OF THE ROOM EXTENSION WHEN IT IS BEING OPERATED. MAKE SURE THERE IS AMPLE ROOM TO EXTEND THE ROOM FULLY.**

**WHEN ROUTING OR REROUTING HYDRAULIC HOSES AND WIRES, BE SURE THEY ARE NOT EXPOSED TO ENGINE EXHAUST OR ANY HIGH TEMPERATURE COMPONENTS OF THE VEHICLE.**

**NEVER PLACE HAND OR OTHER PARTS OF THE BODY NEAR HYDRAULIC LEAKS. OIL MAY CUT AND PENETRATE THE SKIN CAUSING INJURY OR DEATH.**

**SAFETY GLASSES ARE TO BE WORN TO PROTECT EYES FROM DIRT, METAL CHIPS, OIL LEAKS, ETC. FOLLOW ALL OTHER SHOP SAFETY PRACTICES.**

## NOTES AND CHECKS

**Read and check before proceeding with Trouble Shooting Steps.**

**NOTE: HWH CORPORATION ASSUMES NO LIABILITY FOR DAMAGES OR INJURIES RESULTING FROM THE INSTALLATION OR REPAIR OF THIS PRODUCT.**

1. If the room extension cannot be retracted, see Figures pages MP35.9490 and MP35.952D for temporary measures. Make sure the manual retract valves are closed before trouble shooting.

2. The room extension can be operated any time the park brake is set. The ignition does not have to be in the ON or ACC position.

**3. Make sure the leveling system operates properly. Some problems encountered with the leveling system may create a problem with the room extension.**

4. Check that the oil reservoir is full with the room in the fully retracted position.

5. Batteries should read 12.6 volts. Batteries must be in good condition with no weak cells. An alternator, converter or battery charger will not supply enough power for the system to operate properly. Check between the positive and negative posts of the battery while the pump is running. This will check the battery condition under load.

6. Proper ground of all components is critical. See the electrical circuit for specific grounds required. Faulty grounds, especially for the solenoid manifold or the pump assembly, may cause component damage and /or improper or erratic operation.

**This manual is intended for use by experienced mechanics with knowledge of hydraulic and automotive electrical systems. People with little or no experience with HWH Room Extension systems should contact HWH technical service (800-321-3494) before beginning. Special attention should be given to all cautions, wiring, and hydraulic diagrams.**

**Tightening of hose ends: If tightening a new hose end, make the hose end snug (finger tight) on the fitting, then tighten the hose end 1/3 turn (2 FLATS). If tightening an existing hose end, tighten the hose end to snug plus 1/4 turn (1 FLAT).**

Suggested tools for trouble shooting the HWH room extension systems:

JUMPER WIRES(UP TO 10 GAUGE)  
PRESSURE GAUGE(3500 PSI MIN.)  
MULTI-METER  
12 VOLT TEST LIGHT

**PROCEED WITH THE TROUBLE SHOOTING STEPS ON THE FOLLOWING PAGE**



# TROUBLE SHOOTING

The following is a list of possible problems and solutions which might occur to room extensions. There will be only one power unit / valve assembly to operate the room extension(s) and leveling system. There will be a room control switch for each room extension.

If the leveling system does not operate properly, the room extension(s) may not operate properly.

Unless otherwise noted, the PROBLEM and SOLUTION is for either the FLAT FLOOR or DUAL CYLINDER room extensions with a synchronizing cylinder or the SINGLE CYLINDER GUIDED room extension with any leveling system.

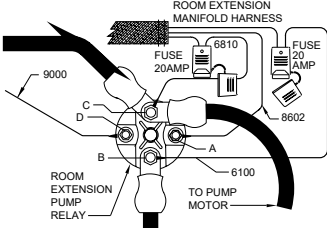
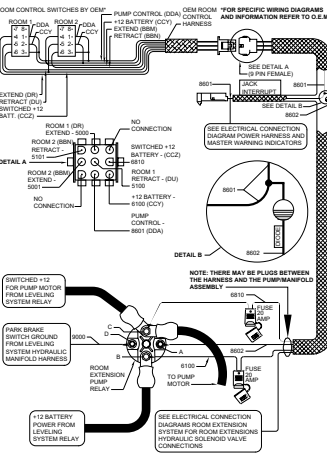
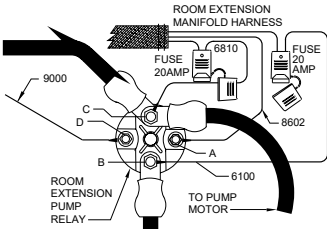
PROBLEM	SOLUTION	FIGURES
<p><b>Part 1</b>  <b>For coaches with two room extensions, the pump will not run when either room control switch is pushed toward EXTEND or RETRACT.</b></p> <p><b>For coaches with one room extension, the pump will not run when the room control switch is pushed toward EXTEND or RETRACT.</b></p> <p><b>NOTE: The room control switch and the harness through the coach is supplied by Winnebago. Only the park brake needs to be set for the room to operate. The ignition can be off.</b></p>	<p>If the leveling system is functioning properly, that should indicate the park brake is set, there is battery power to the relays on the pump and that the pump is functioning.</p> <p>Check terminal B of the room extension relay for +12 power. If there is no power, there is a problem with the connections or cable from the leveling system relay.</p> <p>Check terminal D for a ground. If there is no ground present, there is a problem with the connection at terminal D or a problem with the 9000 wire in the leveling system manifold / pump harness.</p> <p><b>If there is power on terminal B and ground on terminal D,</b> Check the 20 amp fuse in the 6100 wire. This supplies +12 battery power to the room control switch(es).</p> <p><b>If the fuse is blown,</b> replace the fuse. If the fuse blows immediately, the HWH 6100 wire or the Winnebago CCY wire is shorted to ground. If the fuse does not blow, remove the 8602 wire from terminal A. Push a room control switch to EXTEND or RETRACT. If the fuse blows, the HWH 8601 or 8602 wire, or the Winnebago DDA wire is shorted to ground. If the fuse does not blow, reattach the 8602 wire to terminal A. Try the room control switch. If the fuse blows, the room extension pump relay is bad and should be replaced. If the pump runs, continue with testing the system.</p> <p><b>If the 20 amp fuse in the 6100 wire is not blown,</b> check the terminals A and C for +12 power while pushing the room control switch. If there is power on terminals A and C there is a problem with the connection at terminal C. Remember if the pump runs for the leveling system it should run for the room extensions.</p>	<div style="text-align: center;">  <p><b>REFER TO MP85.303T (310 LEVELING SYSTEM) OR MP85.313 (610 LEVELING SYSTEM)</b></p> </div> <hr/> <div style="text-align: center;">  <p><b>REFER TO MP85.303Q</b></p> </div> <hr/> <div style="text-align: center;">  <p><b>REFER TO MP85.303T</b></p> </div>
	<p><b>If there is power on terminal A, but not C while pushing the switch,</b> the room extension pump relay is bad and should be replaced.</p>	

# TROUBLE SHOOTING

PROBLEM	SOLUTION	FIGURES
<p><b>Part 1</b> <b>Continued</b></p>	<p><b>If there is no power on terminal A</b>, find the connection for the HWH room extension pump / manifold harness to the Winnebago room control harness. Check for +12 power on the 6100 (CCY) wire at the connection. If power is not present, there is a problem with the 6100 wire. If there is power on the 6100 wire at the connection, check for +12 power on the 8601 (DDA) wire at the connection while pushing a room control switch. If power is present on the 8601 (DDA) wire at the connection, there is a problem with the 8601/8602 wire going to the pump relay.</p> <p>NOTE: There is a diode between the 8601 wire and the 8602 wire in the harness.</p>	<p style="text-align: center;"><b>REFER TO MP85.303Q</b></p>
<p><b>If the coach is equipped with two rooms</b>, the problem should have been located at this time. The CCY wire, +12 battery power, and the DDA wire, pump control, are common to both room control switches. If the pump still does not run, continue with the following tests, there may be a problem with both switches. For the rear room control switch there is a series of connections between the switch and the HWH harness. Refer to specific Winnebago wiring diagrams for the coach being repaired for correct connection information.</p>	<p><b>If there is no power on the 8601 (DDA) wire at the connection while pushing a room control switch</b>, remove the room control switch(es). Check pin 2 of the switch(es) for +12 power. If power is not present, the problem is with the CCY wire or connection for the CCY wire. If power is present on the number 2 pin of the switch(es), push the switch. Check pins 1 and 3 while pushing the switch. If power is present on the number 1 and 3 pins of the switch, the problem is in the DDA wire or the connections for the DDA wire.</p>	<p style="text-align: center;"><b>REFER TO MP85.303Q</b></p>
<p><b>Part 2</b> <b>For coaches with two room extensions. The pump runs when one room control switch is pushed but not the other.</b></p>	<p>Remove the room control switch for the room that does not operate. Check for +12 power on the number 2 pin for the CCY wire. If there is no power, the problem is with the CCY wire or CCY connections to the HWH harness. If there is power on the number 2 pin, check pins 1 and 3 of the switch while pushing the switch to EXTEND and RETRACT. If power is not present, the switch is bad and should be replaced. If power is present on pins 1 and 3 of the switch the problem is the DDA wire or the DDA wire connections to the HWH harness.</p>	<p style="text-align: center;"><b>REFER TO MP85.303Q</b></p>
<p><b>Part 3</b> <b>The pump runs when a room control switch is pushed to EXTEND but not RETRACT OR when a switch is pushed to RETRACT but not EXTEND.</b></p>	<p>Remove the switch that is not functioning properly. Check the connection of the DDA wires to pins 1 and 3 of the switch. If power is present on both pins while pushing the switch to EXTEND and RETRACT, the problem is the DDA wire or DDA wire connections. If power is not present, replace the room control switch.</p>	<p style="text-align: center;"><b>REFER TO MP85.303Q</b></p>

# TROUBLE SHOOTING

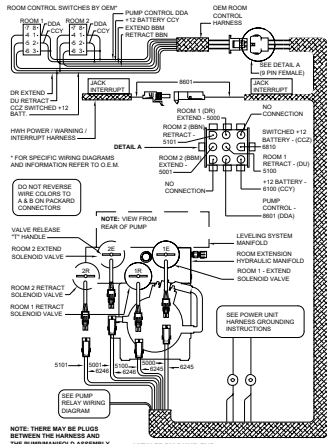
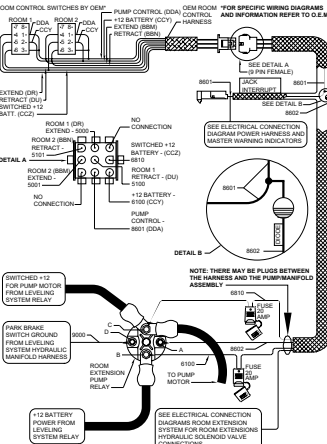
PROBLEM	SOLUTION	FIGURES
<p><b>Part 4</b>  <b>A room will not extend or retract. The pump runs but does not build pressure.</b></p>	<p>Check the operation of the leveling system. A faulty shuttle valve or low pump pressure will cause a problem for the room extension(s).</p> <p>Make sure all valve release "T" handles (large valves) and/or valve release nuts (small valves) are closed (turn clockwise). With the room(s) and jacks fully retracted, check the fluid level in the tank. It should be within 1 inch of the top.</p> <p>If the leveling system is working properly, continue.</p> <p><b>If trying to EXTEND</b>, the retract valve is open. Unplug the retract valve. If the problem stops, the problem is probably the room control switch. If the problem continues, replace the retract valve.</p> <p><b>If trying to RETRACT</b>, the extend valve is open. Unplug the extend valve. If the problem stops, the problem is probably the room control switch. If the problem continues, replace the extend valve.</p>	 <p style="text-align: center;"><b>REFER TO MP85.303J OR MP85.303Q</b></p>
<p><b>Part 5</b>  <b>The pump runs but the room will not extend or retract. The pump seems to be dead heading.</b></p>	<p>There is no power to the room control switch to operate the solenoid valves unless the pump is running. If the room will extend but not retract or will retract but not extend, there is power to the room control switch. The problem is between the room control switch and the solenoid valves. Start troubleshooting at "<b>There is power to terminal 5 of the room control switch.</b>" If the room will neither EXTEND or RETRACT, continue with the next paragraph.</p> <p>Check terminal 5 of the room control switch for 12 volts while pushing the switch to extend or retract. With the pump motor running there should be +12 volts at terminal 5.</p> <p><b>There is no power at terminal 5 of the room control switch.</b> Check the 20 amp fuse in the 6810 wire at the room extension pump relay. <b>If the fuse is OK</b>, the problem is the connection at terminal C of the relay, a problem with the HWH 6810 wire, a problem with the connection of the HWH harness to the Winnebago harness or a problem with the Winnebago CCZ wire or connections in the Winnebago harness. With the pump running, start at the pump relays checking at each connection until the problem is isolated. <b>If the fuse is blown</b>, replace the fuse and push the room control switch to EXTEND. If the fuse blows again, the problem is the EXTEND valve, a short in the HWH 5000 (or 5001) wire, a short in the Winnebago DR (or BBM) wire, the CCZ wire or the 6810 wire. If the fuse does not blow, push the switch to RETRACT. If the fuse blows, the problem is the retract valve, a short in the HWH 5100 (or 5101) wire, or a short in the Winnebago DU (or BBN) wire.</p> <p>If the coach is equipped with two rooms and the 20 amp fuse in the 6810 wire blows when either room is operated the problem is probably a short in the Winnebago CCZ wire on the HWH 6810 wire.</p> <p><b>There is power to terminal 5 of the room control switch.</b> The problem is the room control switch, the harness wires, the ground connections for the solenoid valves or the solenoid valve itself.</p>	 <p style="text-align: center;"><b>REFER TO MP85.303Q</b></p>

# TROUBLE SHOOTING

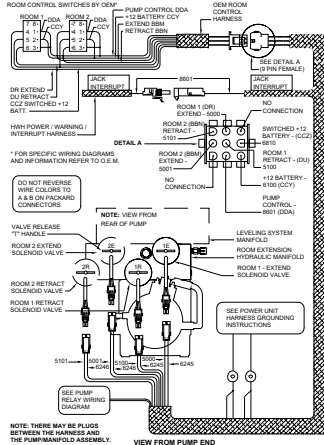
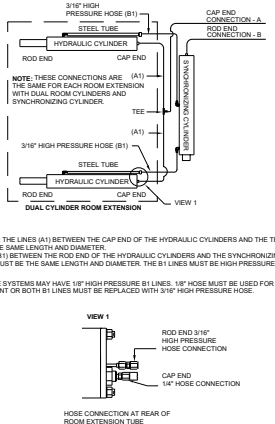
PROBLEM	SOLUTION	FIGURES
<p><b>Part 5 Continued</b></p>	<p><b>If the room will not extend</b>, check terminal 4 of the room control switch while pushing the switch to extend. If +12 volts is not present, replace the switch. If +12 volts is present, unplug the extend solenoid valve and check for +12 volts between the A&amp;B pins of the harness plug, while pushing the switch to extend. If +12 is present, replace the extend solenoid valve. If +12 is not present, check from pin B in the plug to a good frame ground, while pushing the switch to extend. If +12 is present, the problem is the ground wire or pin A for the EXTEND valve. If +12 is not present, the problem is the HWH 5000 (or 5001) wire, the Winnebago DR (or BBN) wire or harness connections between the room switch and the EXTEND valve.</p> <p><b>If the room will not retract</b>, check terminal 6 of the room control switch while pushing the switch to RETRACT. If +12 volts is not present, replace the switch. If +12 volts is present, unplug the retract solenoid valve and check for +12 between the A&amp;B pins of the harness plug while pushing the switch to RETRACT. If +12 is present, replace the retract solenoid valve. If +12 is not present, check between pin B of the harness plug and a good frame ground while pushing the switch to RETRACT. If +12 is present, the problem is the ground wire or pin A for the retract solenoid valve. If +12 is not present, the problem is the HWH 5100 (or 5101) wire, the Winnebago DU (or BBN) wire or harness connections between the room switch and the retract valve.</p>	 <p style="text-align: center;"><b>REFER TO MP85.303J OR MP85.303K</b></p>
<p><b>Part 6 The room moves irrationally from side to side (walking/racking) as it extends or retracts.</b></p>	<p>The room extension mechanisms are designed to allow the room to extend and retract fully at both ends of the room. This allows the room to maintain a proper seal when extended or retracted. Some movement of the room is allowable. Excessive racking is usually caused by the room binding on some obstruction. Check fore and aft adjustments of the room. The room may be binding on carpets, side walls ceilings or room seals. Improper height adjustments can cause the room mechanisms to bind. Awnings can cause the room to rack excessively. Air in the system can cause racking, especially after repairs. Make sure room extension tubes or cylinders are not covered with grease, paint or undercoating.</p> <p><b>DUAL CYLINDER ROOMS WITH SYNCHRONIZING CYLINDER.</b> Improper hose lengths can cause racking. Hoses between the sync cylinder and the rod end of the room cylinders must be the same length and diameter high pressure hose. Hoses from the cap end of the room cylinders and where they tee together must be the same length and diameter. They do not have to be high pressure hose. Cap end and rod end hoses do not have to be the same.</p>	 <p style="text-align: center;"><b>REFER TO MP65.302K</b></p>
<p>If the room is not binding anywhere and the hose lengths are OK, replace the synchronizing cylinder.</p>	<p style="text-align: center;"><b>REFER TO MP45.9953</b></p>	
<p><b>Part 7 The ends of the room do not move at an equal distance from the vehicle. (Dual cylinder rooms only)</b></p>	<p>The system is designed to run unsynchronized for approximately 1 inch at the end of the travel of the room when extending or retracting. This allows the room to seal properly when extended or retracted at the front and rear of the room. As long as the room does not rack excessively and seals properly front and rear when fully extended or retracted, there is no problem and no adjustments that will change this. If the room seems to catching, check up and down adjustments also fore and aft adjustments.</p>	<p style="text-align: center;"><b>REFER TO MP45.9953</b></p>

# TROUBLE SHOOTING

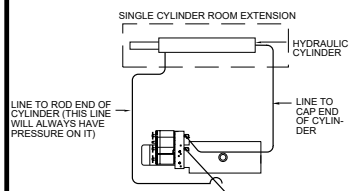
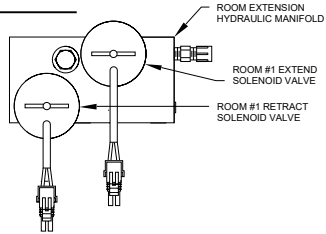
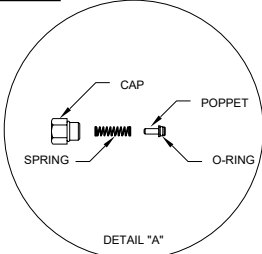
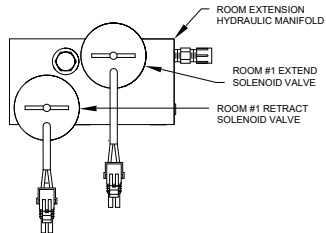
PROBLEM	SOLUTION	FIGURES
<p><b>Part 8</b> The room creeps out after being retracted.</p>	<p>The following deals with either single or dual cylinder room extensions. There are three possibilities:</p> <ul style="list-style-type: none"> <li>A. An extend solenoid valve is leaking.</li> <li>B. A room extension cylinder has an internal leak.</li> <li>C. The manifold check valve is leaking.</li> </ul> <p><b>NOTE :</b> If the room creeps out 1 or 2 inches or less the problem is most likely the check valve.</p> <p>Retract the room completely. Remove the hydraulic line for the cap end of the cylinder at the manifold. Hold the line with the hose end in an upright position. Press the rocker switch for that room to the RETRACT position.</p>	 <p style="text-align: center;"><b>REFER TO MP65.390F OR MP65.390H</b></p>
	<p>If fluid flows from the manifold fitting, the extend solenoid valve needs to be changed.</p>	 <p style="text-align: center;"><b>REFER TO MP85.303J OR MP85.303K</b></p>
	<p>If fluid flows from the hose end, the room extension cylinder should be replaced.</p>	
	<p>If no fluid flows from either the hose end or the manifold fittings, inspect the manifold check valve. There is a spring below the cap. DO NOT lose the spring. Check for cuts on the poppet o-ring. Check the poppet and cap for burrs. The poppet should easily slide in the cap. If the check valve is OK, the problem is most likely the solenoid valve. Support the cap end hose with the hose end up. Allow the system to sit for several hours. Check and see if fluid is seeping from hose or the manifold fitting.</p>	 <p style="text-align: center;"><b>REFER TO MP65.390F OR MP65.390H</b></p>
	<p>To replace a single cylinder room extension cylinder, see MP45.945E.</p>	
	<p>To replace a dual cylinder room extension cylinder, see MP45.9435.</p>	
	<p>To replace a "FLAT FLOOR" room ext. cylinder, see MP45.947A</p>	
<p><b>Part 9</b> The room creeps back in after being extended.</p>	<p>Replace the retract solenoid valve for that room extension. This is the only possibility that would cause this problem.</p>	 <p style="text-align: center;"><b>REFER TO MP85.303J OR MP85.303K MI91.212T 18OCT00</b></p>



# TROUBLE SHOOTING

PROBLEM	SOLUTION	FIGURES
<b>Part 10</b> <b>The room does not seal tightly when fully extended or retracted.</b>	For single cylinder room extensions see MP45.945F. For dual cylinder room extensions see MP45.9436. For "FLAT FLOOR" dual cylinder room extensions see MP45.947D	
<b>Part 11</b> <b>"FLAT FLOOR" ONLY. The room will not drop to the flat position as it extends.</b>	The problem is probably the "FLIPPERS" in the "FLAT FLOOR" mechanism. This is a complicated repair. Contact HWH Customer Service before attempting to make this repair.	

# MANUAL ROOM RETRACT PROCEDURE (WITH SOLENOID VALVES WITH VALVE RELEASE "T" HANDLES)

(USE ONLY WHEN THE ROOM WILL NOT RETRACT WITH THE ROOM CONTROL SWITCH)

## OVERVIEW

The room can be retracted manually if a hydraulic or electric failure prevents the room from being retracted using the CONTROL SWITCH. For normal retract sequence see the ROOM SLIDE RETRACT PROCEDURES. **Refer to the vehicle manufacturer for storage location of the retract device and information for connecting the device to the room.**

**IMPORTANT:** If the vehicle is not equipped with a winch, **DO NOT** use other pulling devices to retract the room. Follow steps 2 and 3 and try pushing the room in. Contact the vehicle manufacturer or HWH Customer Service at 1-800-321-3494 or 563-724-3396 for assistance.

**WARNING:** THE MANUAL RETRACT WINCH IS EQUIPPED FOR MANUALLY RETRACTING THE ROOM ONLY. IT IS NOT TO BE USED FOR LIFTING OR ANY OTHER APPLICATION. HIGH FORCES ARE CREATED WHEN USING A WINCH, CREATING POTENTIAL SAFETY HAZARDS. FAILURE TO FOLLOW ALL CAUTIONS AND INSTRUCTIONS MAY CAUSE FAILURE OF THE MANUAL RETRACT WINCH OR CONNECTIONS RESULTING IN DAMAGE OR PERSONAL INJURY. MAINTAIN FIRM GRIP ON THE WINCH HANDLE AT ALL TIMES. NEVER RELEASE THE HANDLE WHEN RATCHET LEVER IS IN THE OFF POSITION AND THE WINCH IS LOADED. THE WINCH HANDLE COULD SPIN VIOLENTLY AND CAUSE PERSONAL INJURY. CHECK THE WINCH AND STRAPS FOR DAMAGE OR WEAR, AND CHECK FOR PROPER RATCHET OPERATION ON EACH USE OF THE WINCH. DO NOT USE IF DAMAGED OR WORN.

1. Retract jacks following the LEVELING SYSTEM RETRACT PROCEDURE.

**NOTE :** When manually retracting the room, make sure the jacks are retracted before retracting the room.

2. Locate the HYDRAULIC PUMP/MANIFOLD unit.

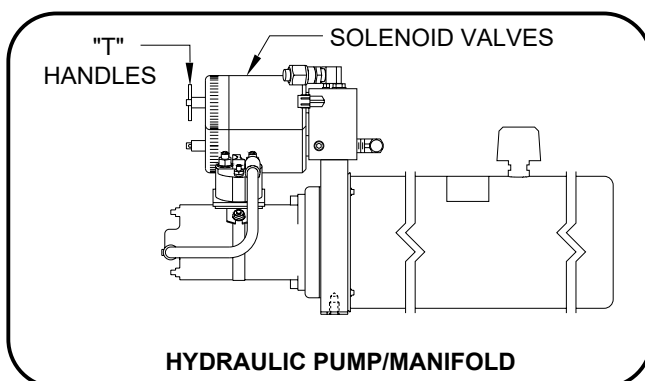

3. Open the SOLENOID VALVES by turning the "T" HANDLES counterclockwise.

**NOTE :** The "T" HANDLE may turn easily at first but will become more difficult to turn as an internal spring is compressed. Be sure to open both valves completely (about six turns of the "T" HANDLE).

**NOTE :** The room may move slightly as the SOLENOID VALVES are opened and internal pressure is released.

4. Locate the MANUAL RETRACT WINCH and connect it to the room according to the vehicle manufacturer's instructions. To extend the WINCH STRAP firmly grasp WINCH HANDLE, place RATCHET LEVER in its OFF position, and slowly rotate the WINCH HANDLE counterclockwise, keeping a firm grip on the handle. When enough WINCH STRAP is extended, place the RATCHET LEVER in its ON position and slowly rotate the WINCH HANDLE clockwise until the RATCHET LEVER locks.

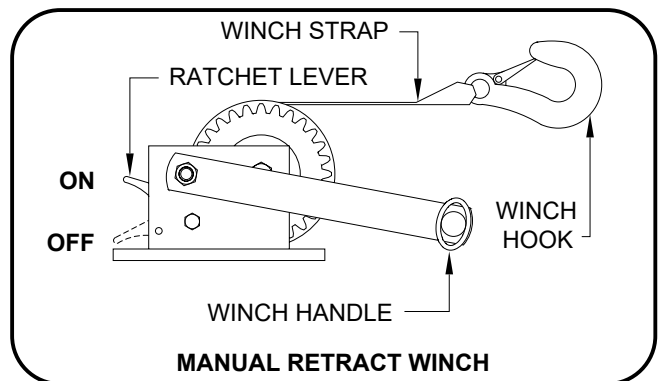

5. Slowly winch the room in by turning the WINCH HANDLE clockwise. The RATCHET LEVER should produce a loud, sharp, clicking noise.

**NOTE :** Winching the room in quickly will raise pressure in the hydraulic fluid and make winching more difficult.

**WARNING:** OPERATE THE MANUAL RETRACT WINCH BY HAND POWER ONLY. IF THE WINCH CANNOT BE CRANKED EASILY WITH ONE HAND IT IS PROBABLY OVER-LOADED. IF WINCHING BECOMES TOO DIFFICULT STOP AND CHECK FOR OBSTRUCTIONS OR RESTRICTIONS ON THE ROOM AND ROOM EXTENSION MECHANISM.

6. When the room is fully retracted, engage the room locking devices. Leave the retract winch in place.

**WARNING:** THE ROOM EXTENSION SOLENOID VALVE "T" HANDLES MUST BE IN THE OPEN POSITION WHEN THE MANUAL RETRACT WINCH IS ENGAGED.

7. The system should be repaired before using again.

# MANUAL ROOM AND GENERATOR SLIDE RETRACT PROCEDURE (WITH SOLENOID VALVES WITH VALVE RELEASE NUTS)

(USE ONLY WHEN THE ROOM WILL NOT RETRACT WITH THE ROOM CONTROL SWITCH)

## OVERVIEW

The room can be retracted manually if a hydraulic or electric failure prevents the room from being retracted using the CONTROL SWITCH. For normal retract sequence see the ROOM SLIDE RETRACT PROCEDURES. Refer to the vehicle manufacturer for storage location of the winch and information for connecting the winch to the room.

**IMPORTANT:** If the vehicle is not equipped with a winch, DO NOT use other pulling devices to retract the room. Follow steps 2 and 3 and try pushing the room in. Contact the vehicle manufacturer or HWH Customer Service at 1-800-321-3494 or 563-724-3396 for assistance.

**CAUTION:** THE MANUAL RETRACT WINCH IS EQUIPPED FOR MANUALLY RETRACTING THE ROOM ONLY. IT IS NOT TO BE USED FOR LIFTING OR ANY OTHER APPLICATION. HIGH FORCES ARE CREATED WHEN USING A WINCH, CREATING POTENTIAL SAFETY HAZARDS. FAILURE TO FOLLOW ALL CAUTIONS AND INSTRUCTIONS MAY CAUSE FAILURE OF THE MANUAL RETRACT WINCH OR CONNECTIONS RESULTING IN DAMAGE OR PERSONAL INJURY. MAINTAIN FIRM GRIP ON THE WINCH HANDLE AT ALL TIMES. NEVER RELEASE THE HANDLE WHEN RATCHET LEVER IS IN THE OFF POSITION AND THE WINCH IS LOADED. THE WINCH HANDLE COULD SPIN VIOLENTLY AND CAUSE PERSONAL INJURY. CHECK THE WINCH AND STRAPS FOR DAMAGE OR WEAR, AND CHECK FOR PROPER RATCHET OPERATION ON EACH USE OF THE WINCH. DO NOT USE IF DAMAGED OR WORN.

1. Retract jacks following the LEVELING SYSTEM RETRACT PROCEDURE.

**NOTE :** When manually retracting the room, make sure the jacks are retracted before retracting the room.

2. Locate the HYDRAULIC PUMP/MANIFOLD unit.

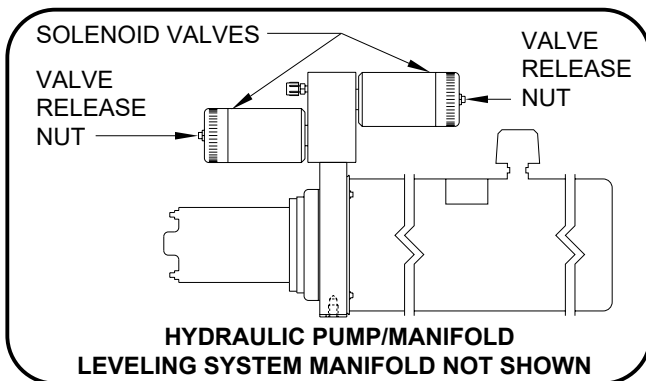

3. Open the Solenoid Valves by slowly turning the valve release nuts counter clockwise using the 1/4" nut driver supplied.

**IMPORTANT:** Only open the valves enough to retract the room. DO NOT turn the release nuts more than 4 and 1/2 turns. Turning the nuts more could damage the valves.

**NOTE:** Prior to APRIL 2002 a 1/4" Nut Driver was sent with the Operators Manual. As of APRIL 2002 the 1/4" Nut Driver has been incorporated into the Breather Cap. See the back page of this manual for further info.

**NOTE:** The room may move slightly as the SOLENOID VALVES are opened and internal pressure is released.

4. Locate the MANUAL RETRACT WINCH and connect it to the room according to the vehicle manufacturer's instructions. To extend the WINCH STRAP firmly grasp WINCH HANDLE, place RATCHET LEVER in its OFF position, and slowly rotate the WINCH HANDLE counter clockwise, keeping a firm grip on the handle. When enough WINCH STRAP is extended, place the RATCHET LEVER in its ON position and slowly rotate the WINCH HANDLE clockwise until the RATCHET LEVER locks.

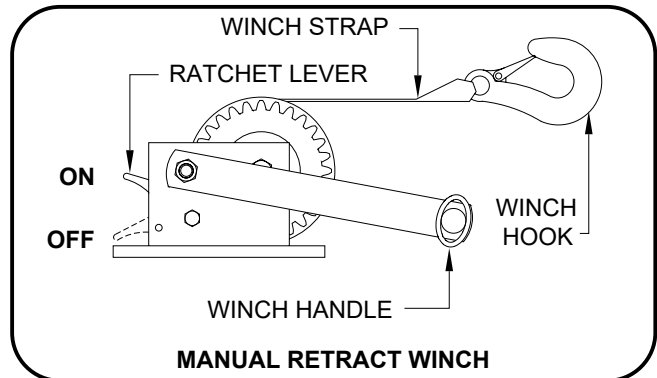

5. Slowly winch the room in by turning the WINCH HANDLE clockwise. The RATCHET LEVER should produce a loud, sharp, clicking noise.

**NOTE:** Winching the room in quickly will raise pressure in the hydraulic fluid and make winching more difficult.

**CAUTION:** OPERATE THE MANUAL RETRACT WINCH BY HAND POWER ONLY. IF THE WINCH CANNOT BE CRANKED EASILY WITH ONE HAND IT IS PROBABLY OVERLOADED. IF WINCHING BECOMES TOO DIFFICULT STOP AND CHECK FOR OBSTRUCTIONS OR RESTRICTIONS ON THE ROOM AND ROOM EXTENSION MECHANISM.

6. When the room is fully retracted, engage the room locking devices. Leave the retract winch engaged and the solenoid valves open.

**CAUTION:** THE ROOM EXTENSION SOLENOID VALVE RELEASE NUTS MUST BE IN THE OPEN POSITION WHEN THE MANUAL RETRACT WINCH IS ENGAGED.

7. The system should be repaired before using again.

**NOTE:** After repairs are made, when closing the VALVE RELEASE NUTS, do not over tighten the nuts.

MP35.952D  
01MAY02

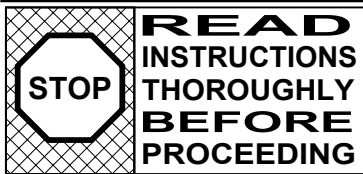

## ROOM EXTENSION CYLINDER REPLACEMENT DUAL CYLINDER ROOM EXTENSION (WITH SYNCHRONIZING CYLINDER)

**IMPORTANT:** The following instructions must be followed or air lock of the synchronizing cylinder and unsynchronized operation of the room cylinders may result causing damage to the room. Please read the instructions before replacing the cylinder. **DO NOT** reverse direction of the room unless the room is fully extended or retracted.

1. Extend the room fully. There is an access hole on the inner sliding tube to access the cylinder rod mounting nuts. If the room cannot be fully extended the inner sliding tube access hole must be extended far enough to access the cylinder rod mounting nuts.

2. Loosen the extend valve "T" Handle/Valve release nut.

3. Loosen the retract valve "T" Handle/Valve release nut.

4. Remove the two nuts and washers from the cylinder cap end mounting plate for both the front and rear room cylinders.

**IMPORTANT:** Steps 4 and 5 must be done to protect the room from being damaged while bleeding air from and synchronizing the the room cylinders.

5. Remove the cylinder rod outer out stop adjusting nut for both the front and rear room cylinders.

6. Remove and cap the hoses at the end of the cylinder that is to be replaced.

7. Remove the cylinder that is to be replaced from the room extension tube.

**NOTE:** Do not remove the caps from the new cylinder hose connections until you are ready to reattach the hoses. Save the caps.

8. Remove the cylinder cap end mounting plate from the old cylinder and attach it to the new cylinder.

9. Install the inner out stop adjusting nut and lock washer completely onto the threaded rod of the new cylinder.

**IMPORTANT: DO NOT PULL THE CYLINDER ROD OUT OF THE NEW CYLINDER. INSTALL THE NEW CYLINDER WITH THE ROD RETRACTED AS IT WAS SHIPPED.**

**IMPORTANT: BEFORE INSTALLING THE NEW CYLINDER, CLEAN ALL EXCESS OIL FROM THE ROOM EXTENSION TUBE. SWAB THE TUBE THOROUGHLY WITH A MILD SOLVENT AND RAGS. EXCESS OIL LEFT IN THE TUBE MAY LEAK OUT GIVING THE APPEARANCE OF A LEAKY CYLINDER OR HOSE CONNECTION.**

10. Install the new cylinder in the room extension tube. **DO NOT** install the two cylinder cap end mounting plate nuts and washers.

11. Attach the hoses to the cylinder. Do not over tighten the hose ends. See MP45.9436 for tightening of hoses.

12. Remove Hose A from the room extension manifold. Use a cap from the new cylinder to cap the fitting in the manifold. Direct Hose A into the fluid reservoir.

13. Close the extend & retract valve "T" handles/Valve release nuts.

14. Push and hold the room control switch to "EXTEND" until the new cylinder is fully extended plus five seconds.

**NOTE:** The cap end of the cylinder will push the cylinder cap end mounting plate off the room extension tube. This is ok.

15. Reattach Hose A to the room extension manifold.

16. Push and hold the room control switch to "RETRACT" until both cylinders are fully retracted, plus 5 seconds. Extend and retract the cylinders at least twice or until they are running fully synchronized. **DO NOT** reconnect the cylinders until they are running fully synchronized.

**CAUTION: DO NOT TRY TO LINE THE ROOM CYLINDER ROD UP WITH THE MOUNTING HOLE WHILE THE ROD IS EXTENDING.**

17. Slide the cylinder rod thru the rod mounting plate hole on the inner sliding tube. Install the nuts and lock washers on the cylinder cap end mounting plate. Turn the cylinder rod inner adjusting nut into place and install the cylinder rod outer adjusting nut. Make the nut snug only, as a final adjustment will have to be made. Do this for the front and rear cylinders.

**IMPORTANT: Do not reverse direction of the room until the room is fully extended or retracted.**

18. Push the room control switch to retract and hold until the room is fully retracted plus 5 seconds. Watch for excessive racking of the room. Some racking can occur do to air in the system. If the room starts to bind up, release the room control switch immediately. If the room does not bind up, proceed to Step 20. If the room is bound up, go to Step 19.

19. If the room is bound up, repeat Steps 2, 3, 4 and 5. Manually push the room out to its full extension. Now repeat Steps 13, 16, 17 and 18. If the room will still not run properly, contact HWH CORPORATION Customer Service at (800)321-3494 or at (563)724-3396.

20. Extend the room fully again. Do not reverse direction until the room is fully extended. Repeat retracting and extending the room several times being careful not to reverse directions until the room is fully extended or retracted.

21. With the room fully extended, check seals for proper compression. If the seal is not compressed or needs more compression, loosen the cylinder rod outer adjusting nut and tighten the cylinder rod inner adjusting nut. If the seal is compressed too much, loosen the cylinder rod inner adjusting nut and tighten the cylinder rod outer adjusting nut.

22. Check all hose connections and mounting nuts and bolts for tightness and leaks.

# CYLINDER REPLACEMENT DUAL CYLINDER ROOM EXTENSION WITH SYNCHRONIZING CYLINDER

**NOTE:** ROD AND CAP END HOSE CONNECTIONS WILL BE THE SAME FOR MULTIPLE ROOM EXTENSIONS.

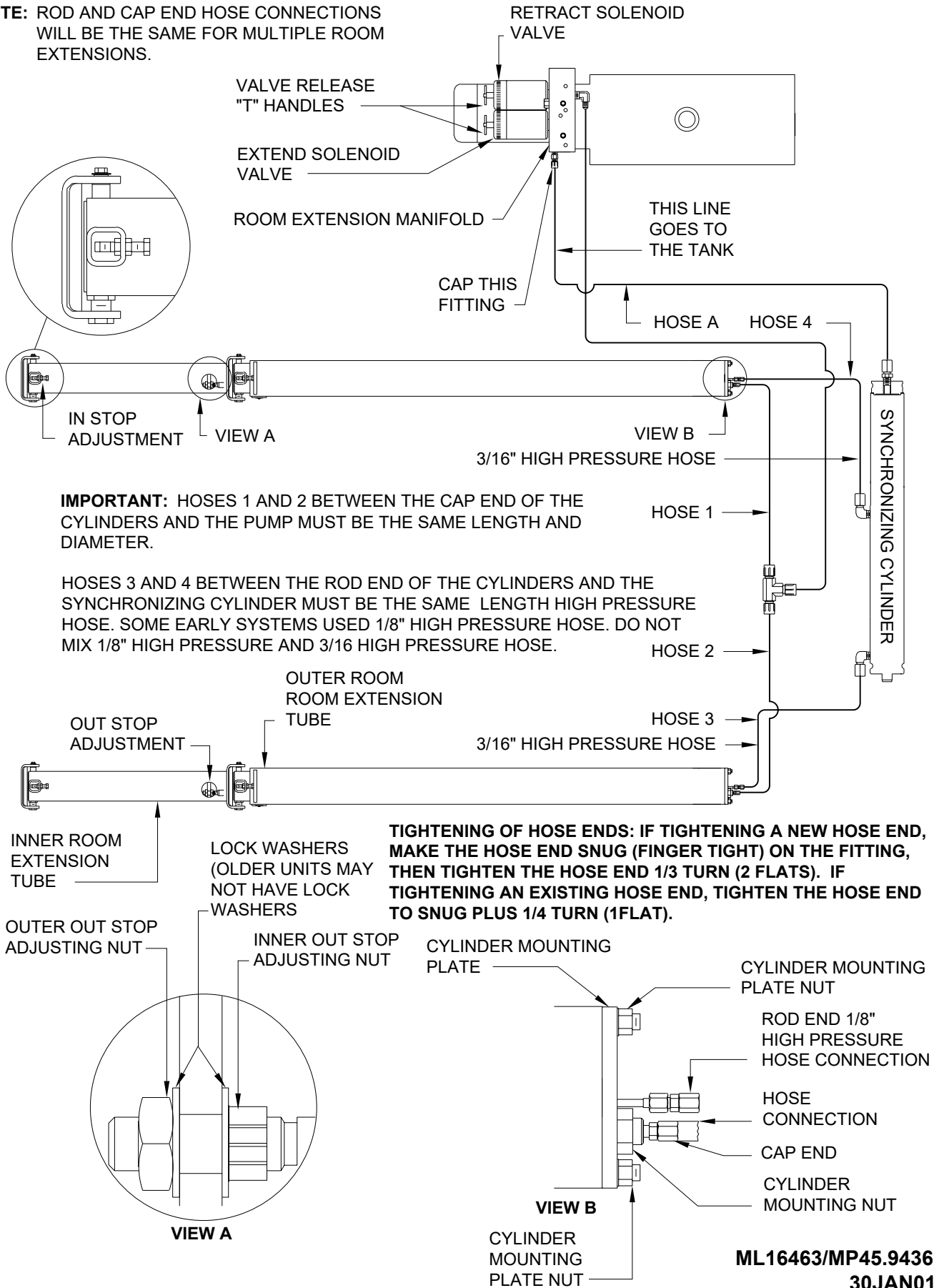

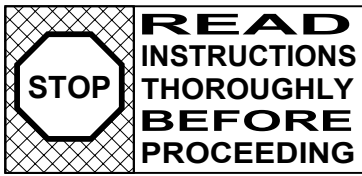

## ROOM EXTENSION CYLINDER REPLACEMENT SINGLE CYLINDER "GUIDED" ROOM EXTENSION WITH ROOM EXTENSION MANIFOLD

**IMPORTANT:** Read and follow these instructions carefully when replacing a room cylinder. Protect the coach interior. Refer to the ROOM EXTENSION DIAGRAM - CYLINDER REPLACEMENT for views of the room extension equipment.

**NOTE:** Do not remove the caps from the new cylinder hose until you are ready to reattach the new hoses.

1. Extend the room fully.
  2. Remove the bed and any necessary equipment to gain access to the room extension tube.
  3. Open the extend, then the retract solenoid valves for the room. Do this by turning the valve release T-handles counter clockwise.
  4. Remove the plug from the rod end mounting bolt access hole.
  5. Remove the rod end mounting bolt and nut.
  6. Close the extend and retract solenoid valves.
  7. Retract the room cylinder.
  8. Open the extend, then the retract solenoid valves.
  9. Remove the tube end mounting nut and tube end seal.
  10. Remove the cap end cylinder mounting bolts.
  11. Disconnect and cap the hoses from the room extension manifold. Cap the manifold fittings.
  12. Remove the cylinder and hoses, carefully guiding the hoses through the slot.
  13. Transfer the hoses onto the new cylinder.
- Tightening of hose ends: If tightening a new hose end, make the hose end snug (finger tight) on the fitting, then tighten the hose end 1/3 turn (2 FLATS). If tightening an existing hose end, tighten the hose end to snug plus 1/4 turn (1 FLAT).**
14. **Clean any oil spills or leakage from the floor and tube before installing the new cylinder.** Install the new cylinders carefully guiding the hoses into place.
  15. Reconnect the hydraulic hoses to the room extension manifold.
  16. Line up the cap end cylinder mounting holes and install the cap end cylinder mounting bolts.
  17. Carefully extend the cylinders to the rod mounting plate. Line the rod up with the mounting hole extend the rod into the hole. Install the rod mounting bolt and nut.
  18. Make sure all bolts and hose connections are tight.
  19. Close the extend and retract solenoid valves.
  20. Push the room control switch to extend 3 or 4 seconds.
  21. Push the room control switch to retract. Hold the switch until the room is fully retracted, plus 5 seconds.  
**IMPORTANT:** Watch carefully for unnatural movement of the room. Release the room control switch immediately if the room binds up.
  22. Extend and retract the room several times and check for leaks.
  23. Reassemble the bedroom.

# ROOM EXTENSION DIAGRAM

## SINGLE CYLINDER "GUIDED" ROOM EXTENSION

### CYLINDER REPLACEMENT AND ADJUSTMENT

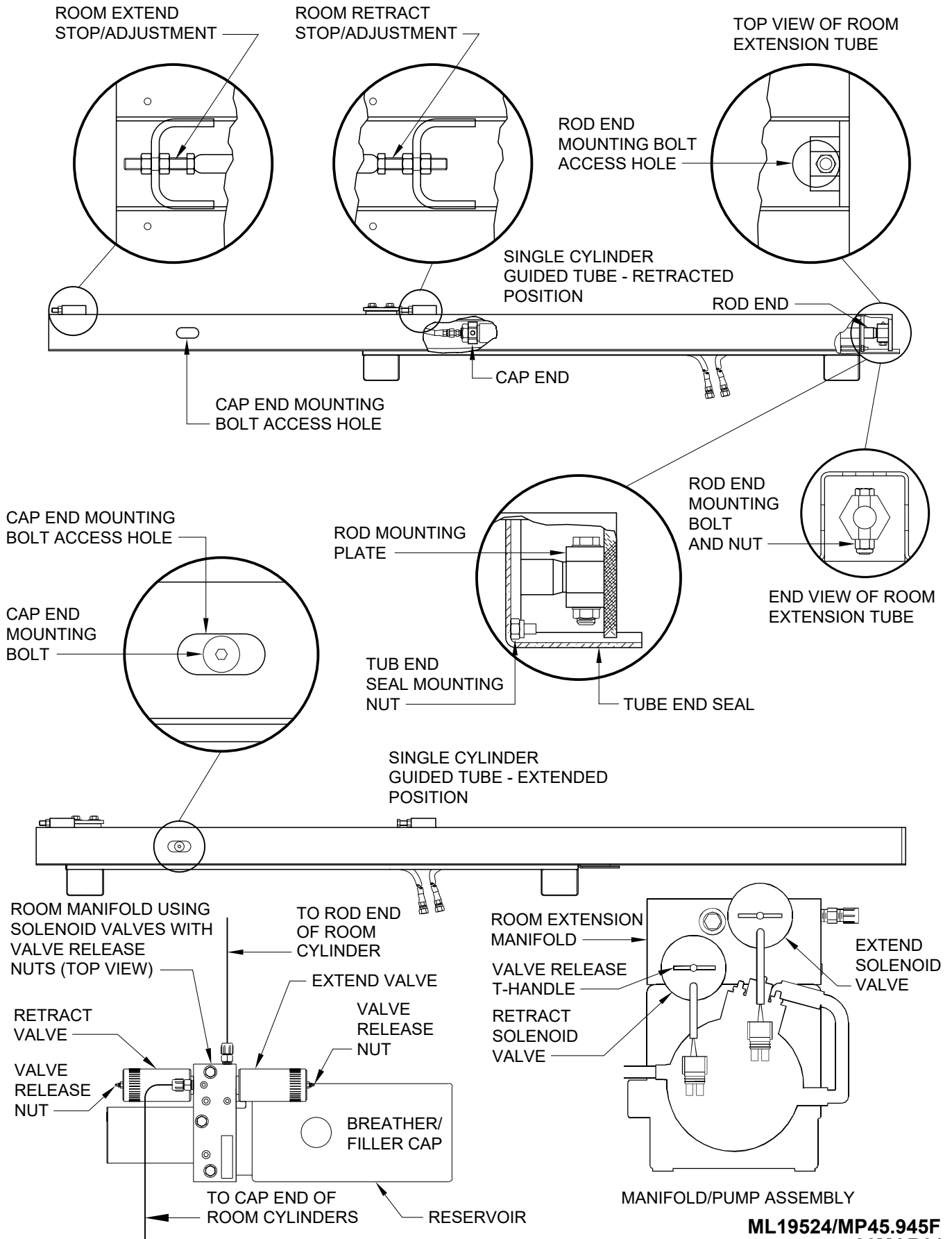



**READ  
INSTRUCTIONS  
THOROUGHLY  
BEFORE  
PROCEEDING**

## **ROOM EXTENSION CYLINDER REPLACEMENT DUAL CYLINDER FLAT FLOOR ROOM EXTENSION (WITH SYNCHRONIZING CYLINDER)**

**IMPORTANT: The following instructions must be followed or air lock of the synchronizing cylinder and unsynchronized operation of the room cylinders may result causing damage to the room. Please read the instructions before replacing the cylinder. DO NOT reverse direction of the room unless the room is fully extended or retracted.**

1. Extend the room until the rod mounting pin is visible. Make sure the room is not starting to "LOWER". Support the room

**NOTE: Some rooms may need to be fully extended and supported to access the pin.**

2. Remove the mounting pin from both front and rear cylinders.

3. Push the room control switch to "EXTEND" until both cylinders are fully extended.

4. Open the extend valve "T" handle or valve release nut.

5. Open the retract valve "T" handle or valve release nut.

**NOTE: Valve release nuts should not be opened more than four (4) turns.**

6. Remove trunnion bolts (2) that mount the rear of the cylinder that is to be changed.

7. Mark the hoses so they are replaced in the correct position. Remove and cap the hoses from the cylinder connections.

8. Remove the cylinder. The cylinder may need to be lifted slightly so the rod eye does not catch on the STORE-MORE mounting that protrudes inside of the inner tube.

9. Measure the cap end cylinder mounting nut on the bad cylinder. Make sure the mounting nut is in the same position on the new cylinder.

10. Install the rod end hose from the old cylinder onto the new cylinder.

**Tightening of hose ends: If tightening a new hose end, make the hose end snug (finger tight) on the fitting, then tighten the hose end 1/3 turn (2 FLATS). If tightening an existing hose end, tighten the hose end to snug plus 1/4 turn (1 FLAT).**

11. Install the new cylinder. Support the cylinder so the rod eye does not catch the STORE-MORE mounting.

12. Install the trunnion bolts (2).

13. Attach the hoses to the new cylinder. DO NOT reverse hose connections.

14. Remove hose A from the room extension manifold. Use a steel cap from the new cylinder to cap the fitting in the manifold. Direct hose A into the fluid reservoir.

15. Close the "T" handles or valve release nuts.

**IMPORTANT: When extending or retracting the cylinders when the rod eye is not connected to the tube, the rod eye may catch on the STORE-MORE mounting. If necessary place a small block under both cylinders to raise the rod eye above the "STORE-MORE" mounting. Make sure it is not blocked so high it interferes with anything else in the tube. MOST OF ALL PAY ATTENTION.**

16. Push and hold the room control switch to "EXTEND" until the new cylinder is fully extended plus 5 seconds.

17. Open the extend valve then the retract valve "T" handles or valve release nuts.

18. Reattach hose A to the room extension manifold.

19. Close both valve "T" handles or valve release nuts.

20. Push and hold the room control switch to "RETRACT" until both cylinders are fully retracted plus five seconds. Repeat extending and retracting the cylinders AT LEAST 2 more times or until the cylinders are running fully synchronized.

21. Fully extend the cylinders then retract the cylinders so the hole in the rod eye and inner tube line up and install the pin and snap rings for both cylinders. It may be necessary to loosen the trunnion jam nuts to line up the mounting holes. Make sure the trunnion (cylinder mounting nut) is in the same position after tightening the jam nuts.

22. Push the room control switch to "RETRACT" and hold until the room is fully retracted plus 5 seconds. Watch for excessive racking of the room. Some racking can occur due to air in the system. If the room does not bind up, proceed to STEP 24. If the room is bound up proceed to STEP 23.

23. If the room is bound up and the rod eye pins are not visible, repeat STEP 6 for both cylinders and manually do STEP 1 then 2. Repeat STEPS 12 and 20 thru 22. If the room will still not run properly, contact HWH Customer Service 1-800-321-3494.

24. Extend the room fully again. DO NOT reverse direction until the room is fully extended. Repeat retracting and extending the room several times. DO NOT reverse directions until the room is fully extended or retracted.

25. Check and make room adjustments in this order: drop, extend and then retract.



# CYLINDER REPLACEMENT

## DUAL CYLINDER "FLAT FLOOR" ROOM EXTENSION

### WITH SYNCHRONIZING CYLINDER

**NOTE:** ROD AND CAP END HOSE CONNECTIONS WILL BE THE SAME FOR MULTIPLE ROOM EXTENSIONS.

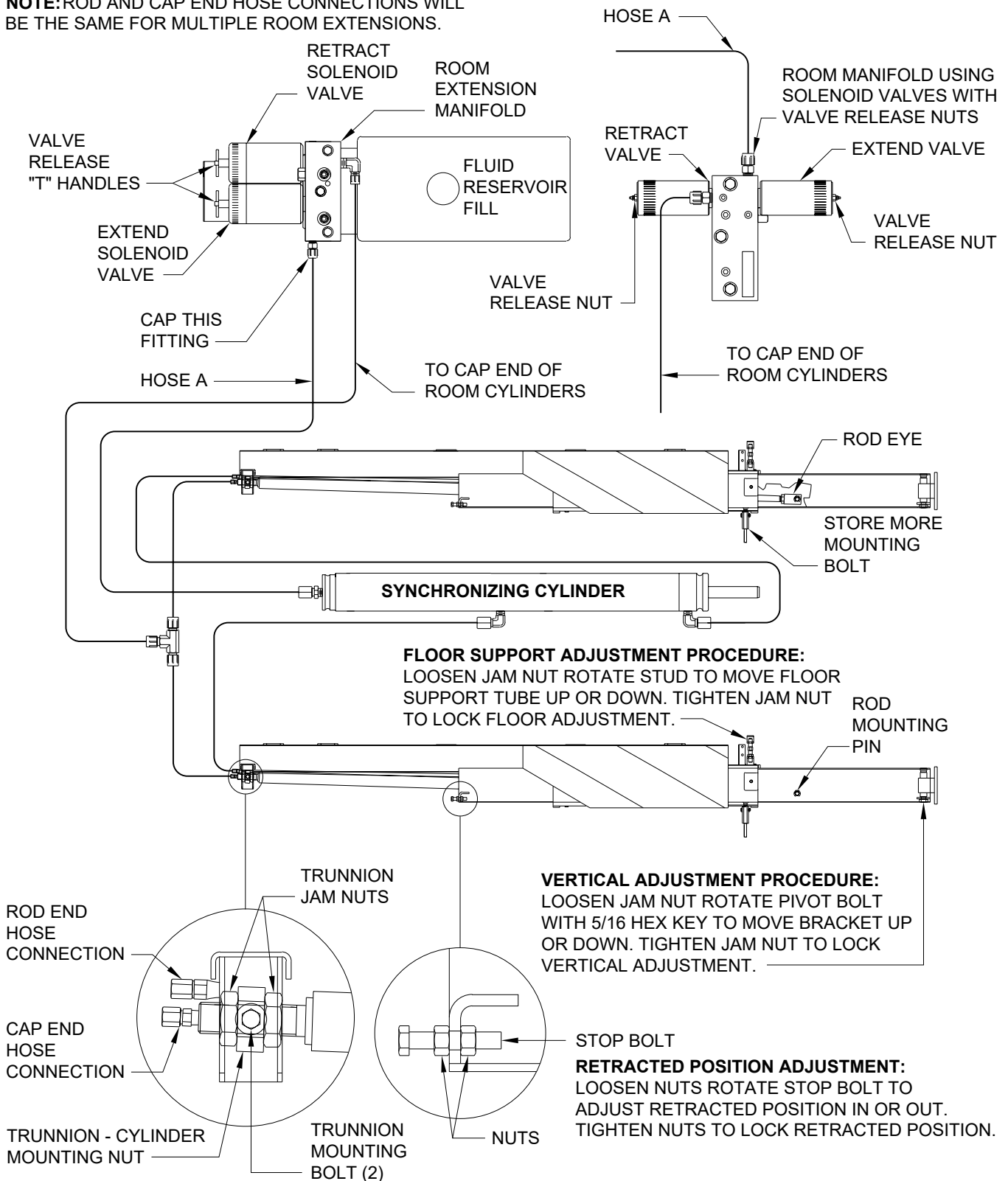

**DROP ADJUSTMENT PROCEDURE:**  
 LOOSEN JAM NUTS ROTATE JAM NUTS IN OR OUT TO MOVE DROP ADJUSTMENT UP OR DOWN. TIGHTEN JAM NUTS TO LOCK DROP ADJUSTMENT.



**READ  
INSTRUCTIONS  
THOROUGHLY  
BEFORE  
PROCEEDING**

## **SYNCHRONIZING CYLINDER OR HOSE ASSEMBLY REPLACEMENT ALL DUAL CYLINDER ROOM EXTENSIONS (WITH SYNCHRONIZING CYLINDER)**

**IMPORTANT:** The following instructions must be followed or air lock of the synchronizing cylinder and unsynchronized operation of the room cylinders may result causing damage to the room. Please read the instructions before replacing the cylinder. **DO NOT reverse direction of the room unless the room is fully extended or retracted.**

Refer to the correct room cylinder replacement sheet for information concerning room cylinder removal and replacement and any adjustments that need to be made.

1. Fully extend or retract the room according to the correct room cylinder replacement sheet.
2. Disconnect the end of both rods from the room extension mechanism.
3. Retract the rods completely.

**NOTE: Room cylinders must be fully retracted before replacing the synchronizing cylinder or hose assembly.**

4. Loosen the extend valve "T" handle.
5. Loosen the retract valve "T" handle.

**NOTE: If the system uses a reversible pump instead of a room manifold, open the one emergency retract valve.**

---

### **SYNCHRONIZING CYLINDER REPLACEMENT**

1. Remove and cap the hoses to the synchronizing cylinder.

**NOTE: DO NOT remove the caps from the new cylinder hose connections until you are ready to attach the hoses. Save the caps.**

2. Replace the synchronizing cylinder and reattach the hoses to the proper connections. **DO NOT** over tighten the hose connections.

**Tightening of hose ends: If tightening a new hose end, make the hose end snug (finger tight) on the fitting, then tighten the hose end 1/3 turn (2 FLATS). If tightening an existing hose end, tighten the hose end to snug plus 1/4 turn (1 FLAT).**

### **HOSE ASSEMBLY REPLACEMENT**

Remove and replace the hose assembly. Tighten the hose ends according to the above tightening procedure.

---

### **BLEEDING PROCEDURE**

1. Remove hose A from the room extension manifold. Use a cap from the new cylinder to cap the fittings in the manifold. Direct hose A into the fluid reservoir.
2. Close the extend and retract valve "T" handles/Valve release nuts. (The emergency retract valve if a reversible pump is used.)
3. Extend the rods completely. Hold the room control switch on for five seconds after the rods are fully extended.

Refer to the correct room cylinder replacement sheet to complete the bleed procedure. Start where the instructions reattach hose A to the pump assembly, or continue on this sheet.

4. Open the cylinder extend valve first, then the cylinder retract valve.
5. Reattach hose A to the manifold fitting and tighten. Close the solenoid valves.
6. Retract and extend the cylinders until they are running together. Cycle the cylinders at least three times, more if needed to synchronize the cylinders. Hold the switch about 5 seconds each time the cylinders are fully extended or retracted.
7. Reattach the cylinders to the room mechanism.
8. Extend and retract the room several times to make sure the room is synchronized. Watch the room closely and release the room switch immediately if the room starts to rack.

If the room will not synchronize, contact HWH for assistance.

# SYNCHRONIZING CYLINDER OR HOSE ASSEMBLY REPLACEMENT ALL DUAL CYLINDER ROOM EXTENSIONS (WITH SYNCHRONIZING CYLINDER)

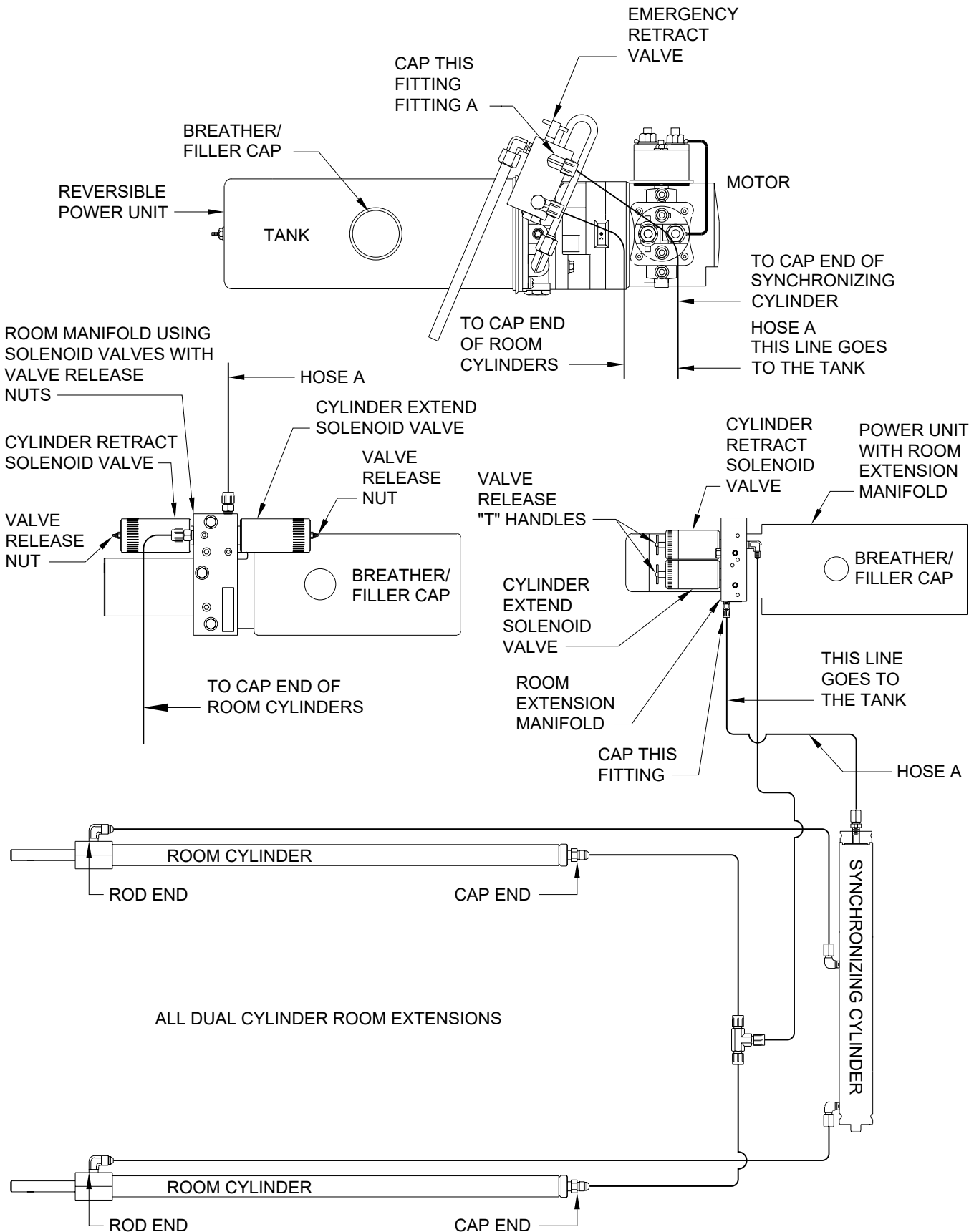

# CYLINDER CONNECTION DIAGRAM DUAL CYLINDER ROOM EXTENSIONS (WITH SYNCRONIZING CYLINDER)

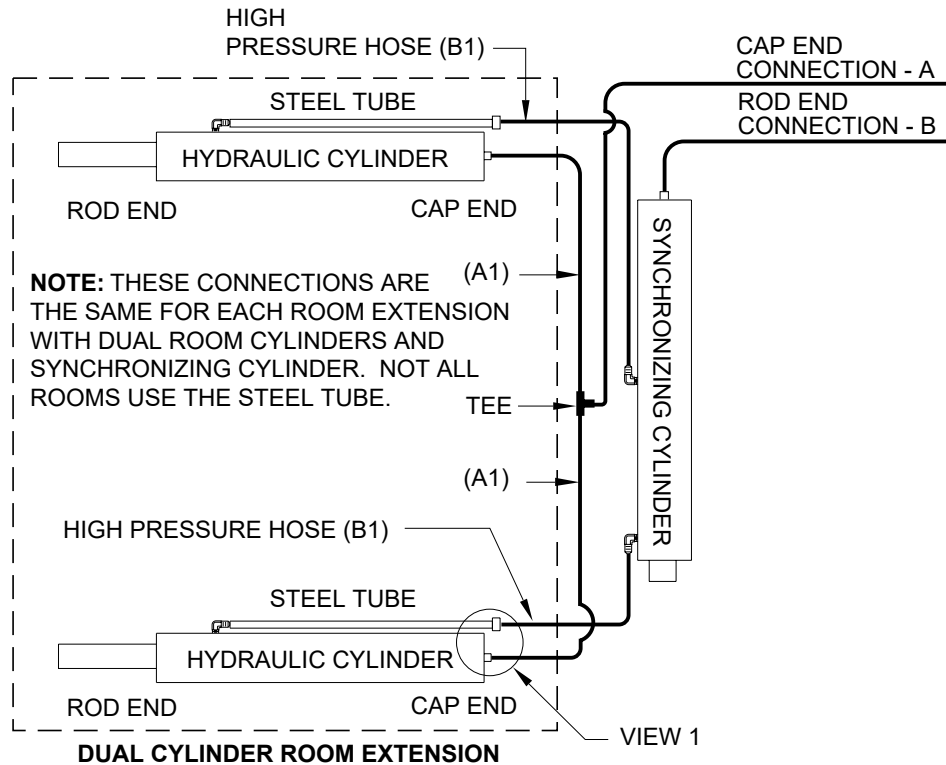

**IMPORTANT:** THE LINES (A1) BETWEEN THE CAP END OF THE HYDRAULIC CYLINDERS AND THE TEE MUST BE THE SAME LENGTH AND DIAMETER. THE LINES (B1) BETWEEN THE ROD END OF THE HYDRAULIC CYLINDERS AND THE SYNCRONIZING CYLINDER MUST BE THE SAME LENGTH AND DIAMETER. THE B1 LINES MUST BE HIGH PRESSURE HOSE.

**NOTE:** DIFFERENT TYPES OF HOSE, ESPECIALLY HIGH PRESSURE HOSE, HAS BEEN USED. THE PRINTING ON A 1/8" OR 3/16" HOSE BEING REPLACED MUST MATCH THE ORIGINAL HOSE. ALL HWH 1/4" HOSE IS THE SAME.

**VIEW 1**

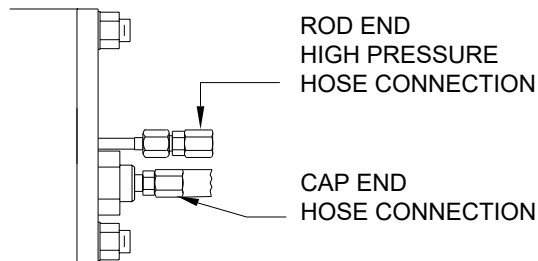

HOSE CONNECTION AT REAR OF ROOM EXTENSION TUBE

---

# HYDRAULIC LINE CONNECTION DIAGRAM SINGLE CYLINDER "GUIDED" ROOM EXTENSION

---

**NOTE:** THE ROD END CONNECTION FROM THE MANIFOLD TO THE ROOM CYLINDER IS ALWAYS PRESSURIZED. ROD CONNECTIONS TO ROOM LOCKS WILL NOT BE PRESSURIZED.

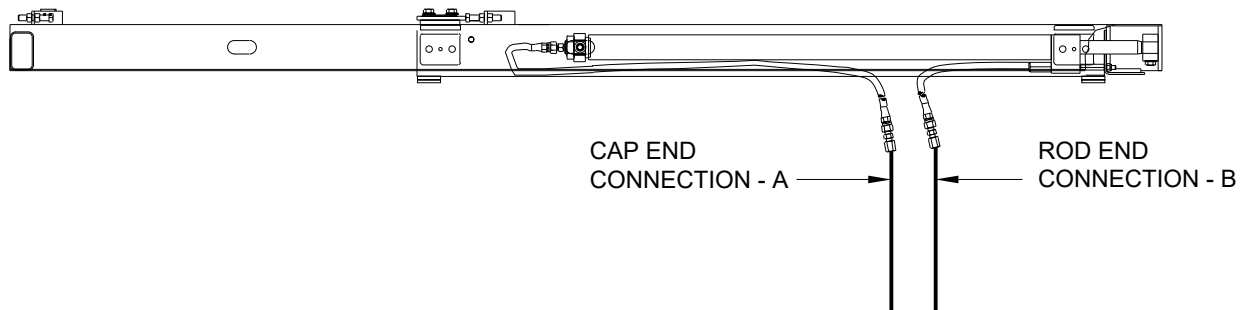

# HYDRAULIC LINE CONNECTION DIAGRAM ROOM EXTENSION - ONE OR TWO ROOMS SOLENOID VALVES WITH VALVE RELEASE "T" HANDLES

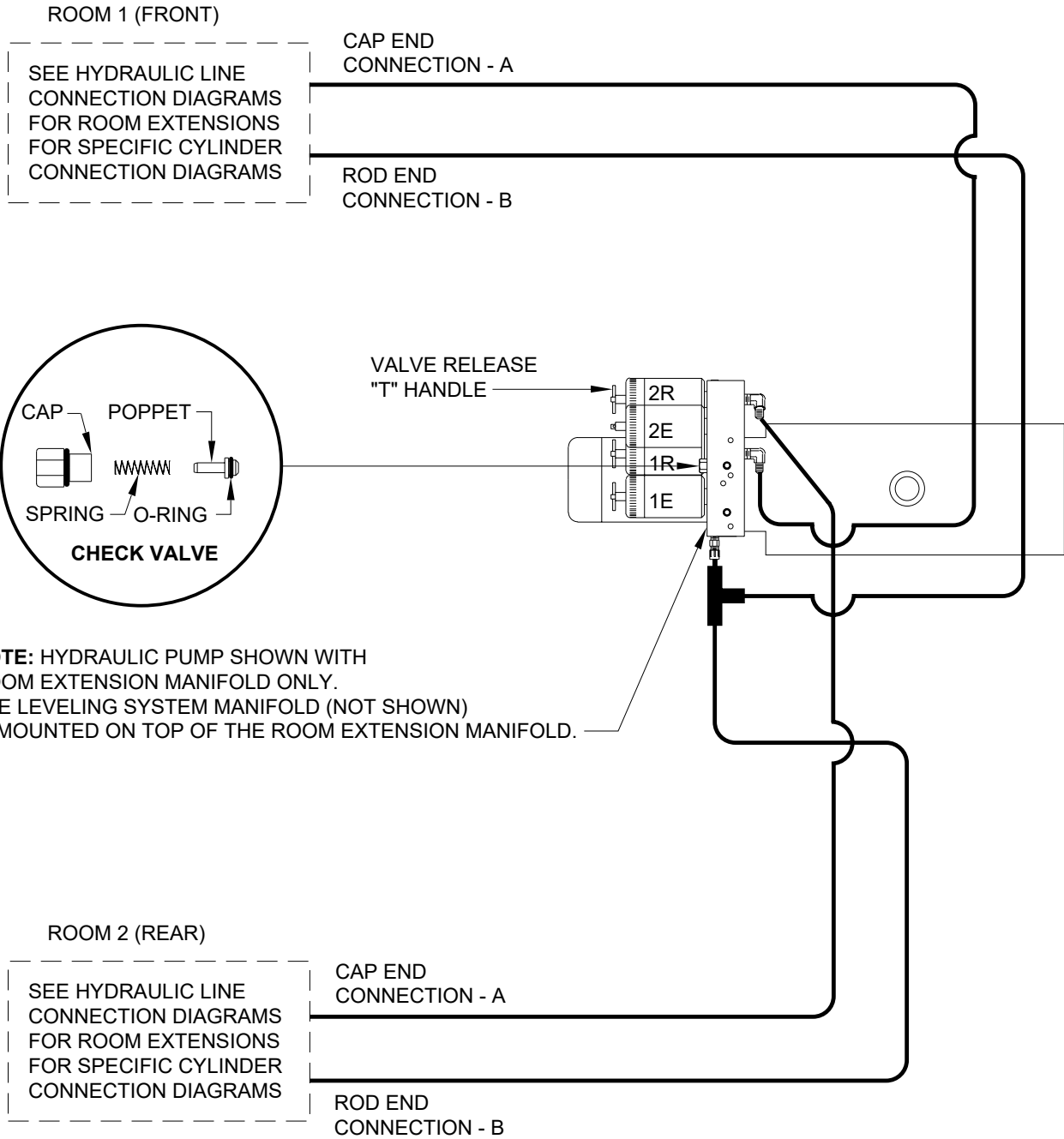

# HYDRAULIC LINE CONNECTION DIAGRAM ROOM EXTENSION - ONE OR TWO ROOMS SOLENOID VALVES WITH VALVE RELEASE NUTS

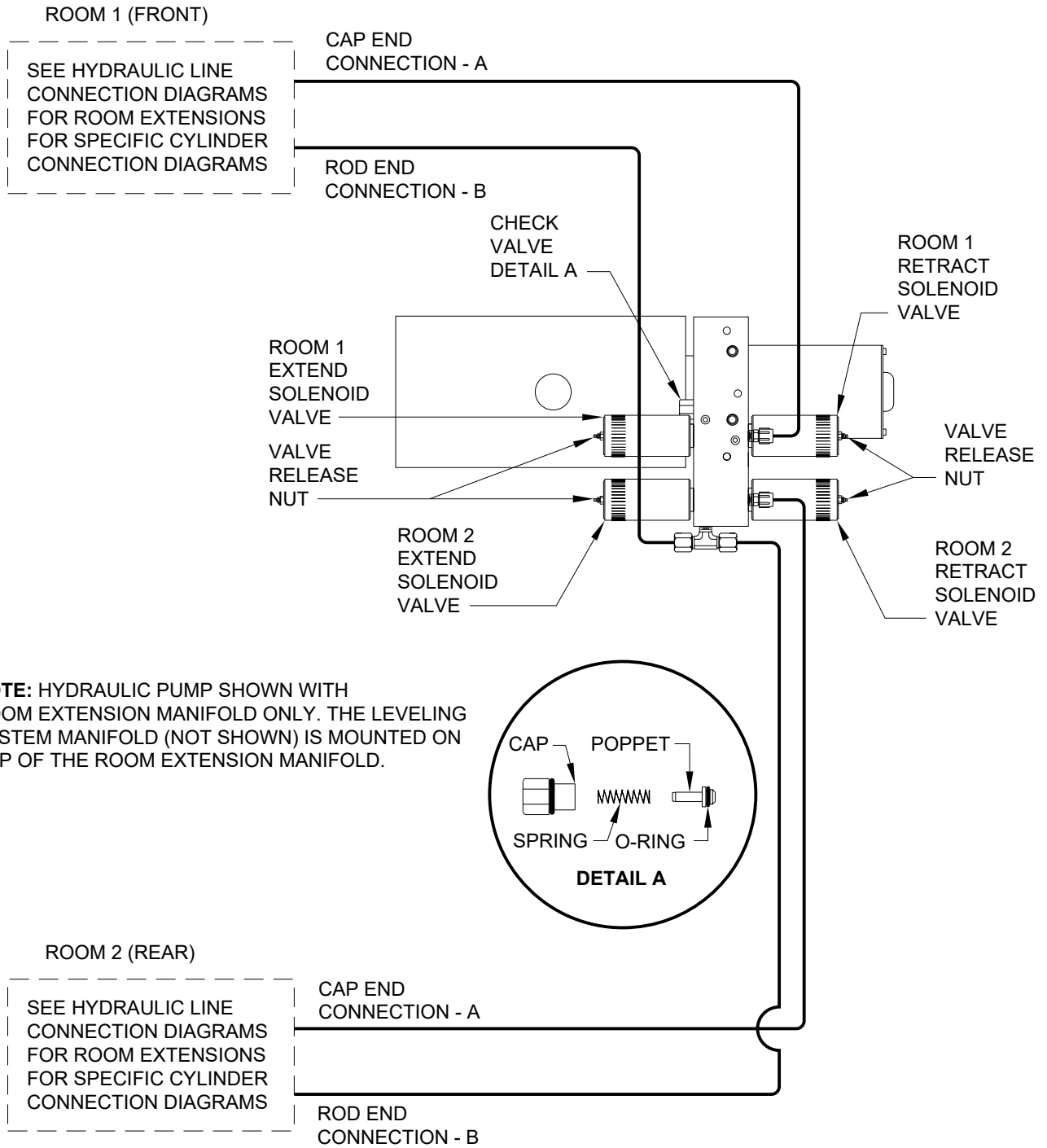

**HYDRAULIC FLOW DIAGRAM  
VERTICAL ARM OR DUAL CYLINDER ROOM EXTENSION  
WITH SYNCHRONIZING CYLINDER  
STATIONARY POSITION**

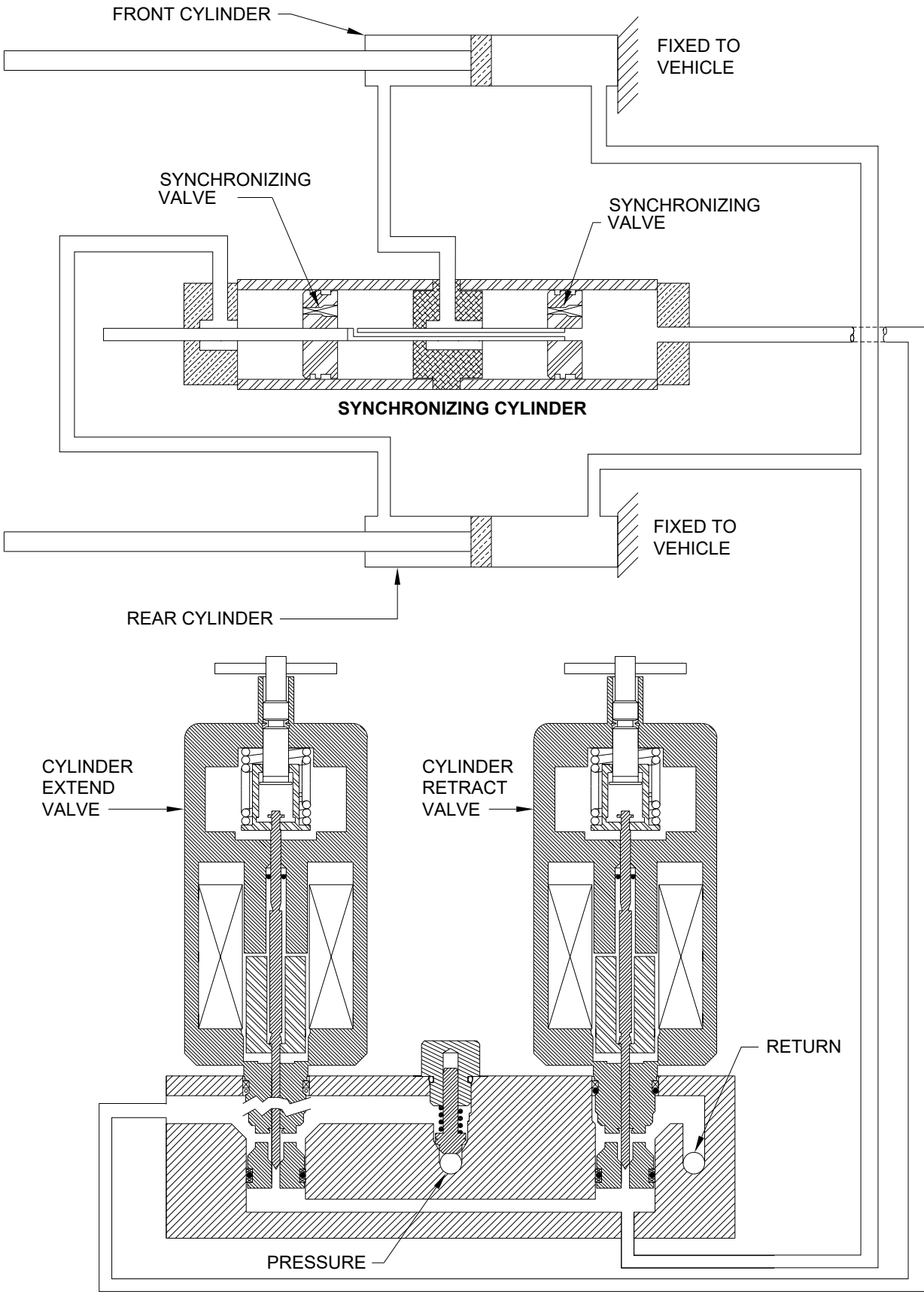



**HYDRAULIC FLOW DIAGRAM  
SINGLE CYLINDER ROOM EXTENSION  
STATIONARY POSITION**

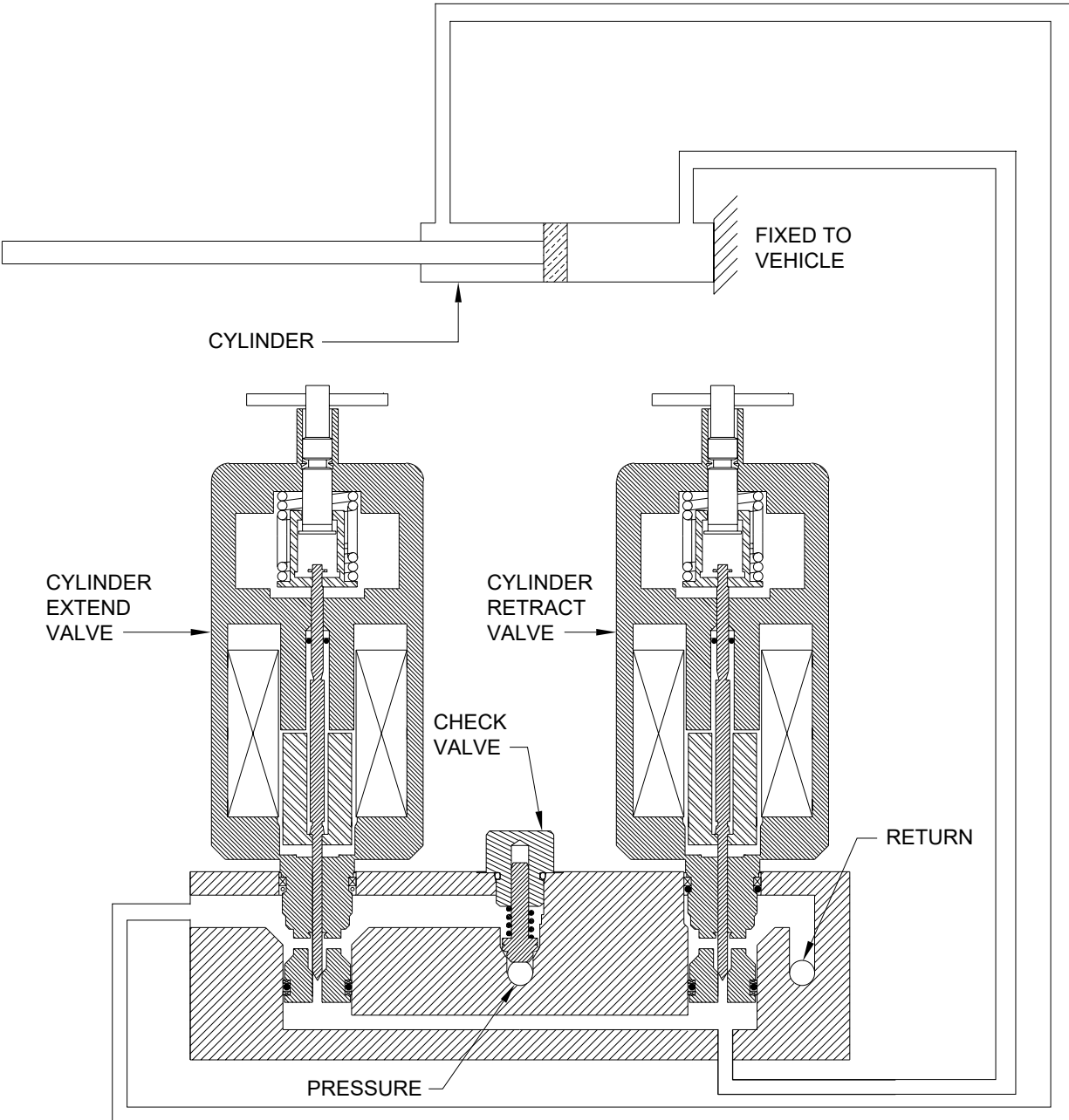

**ELECTRICAL CONNECTION  
DIAGRAMS  
FOR  
COACHES WITH ONE OR TWO  
ROOM EXTENSIONS AND A  
310 SERIES LEVELING SYSTEM  
(NOT FOR COACHES WITH A FOUR CYLINDER  
ROOM EXTENSION)**

# ELECTRICAL CONNECTION DIAGRAM

## TWO ROOM EXTENSION SYSTEM - 310 SERIES LEVELING SYSTEM

### SOLENOID VALVES WITH VALVE RELEASE "T" HANDLES

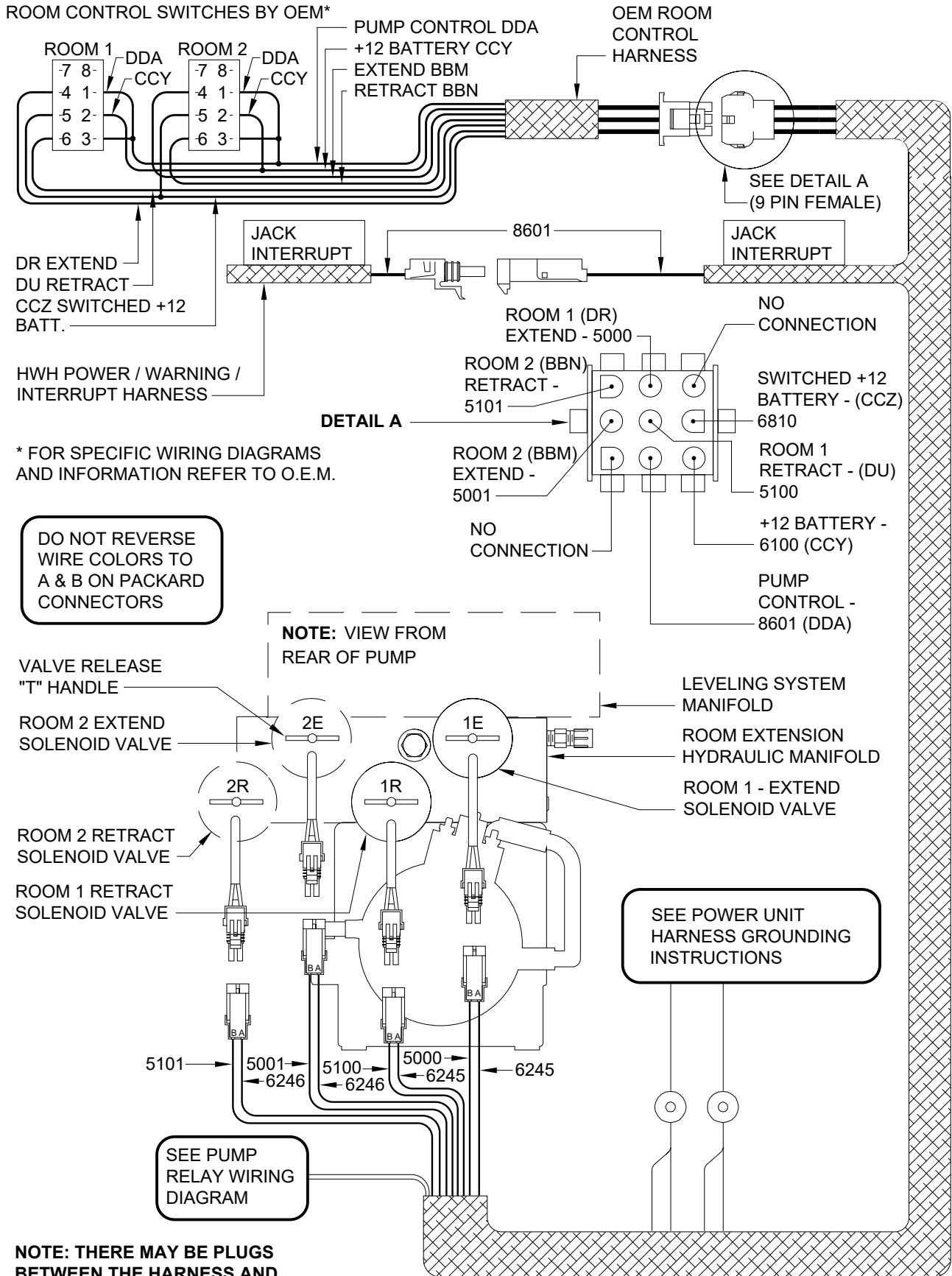

**NOTE: THERE MAY BE PLUGS BETWEEN THE HARNESS AND THE PUMP/MANIFOLD ASSEMBLY.**

**VIEW FROM PUMP END**

**MP85.303J  
18OCT00**

# ELECTRICAL CONNECTION DIAGRAM

## TWO ROOM EXTENSION SYSTEM - 310 SERIES LEVELING SYSTEM

### SOLENOID VALVES WITH VALVE RELEASE NUTS

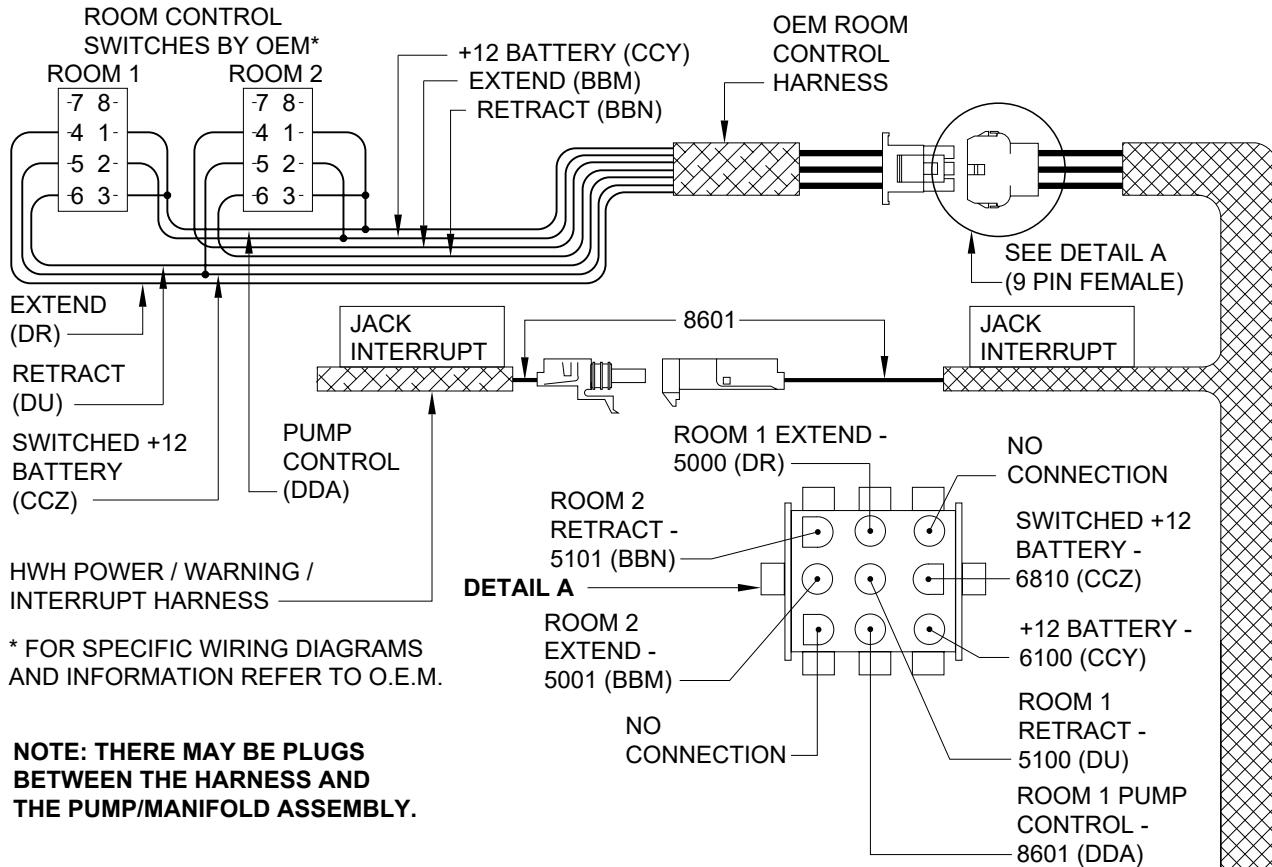

#### TOP VIEW OF PUMP/MANIFOLD

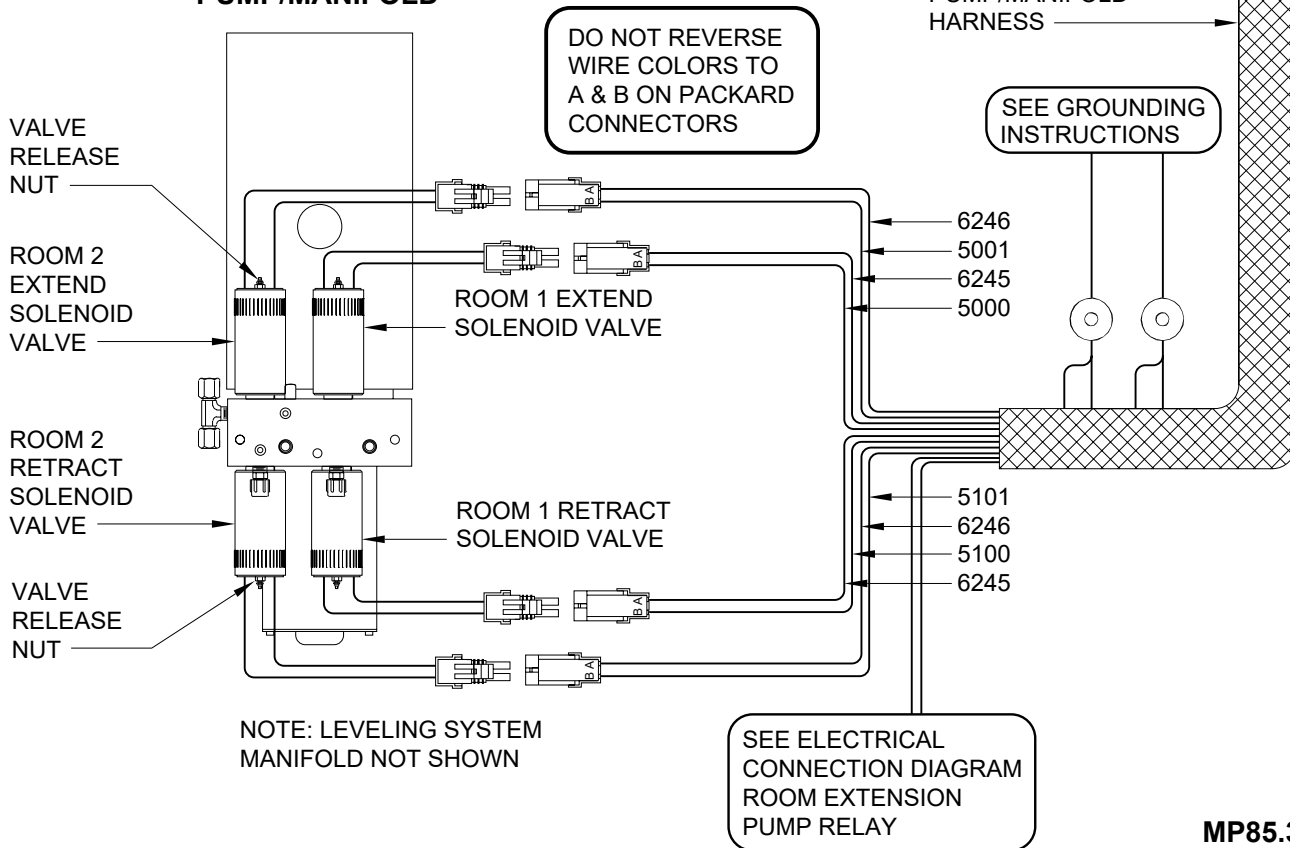

# ELECTRICAL CONNECTION DIAGRAM

## PUMP RELAY INFORMATION

### 310 SERIES LEVELING SYSTEM WITH ONE OR TWO ROOM EXTENSIONS

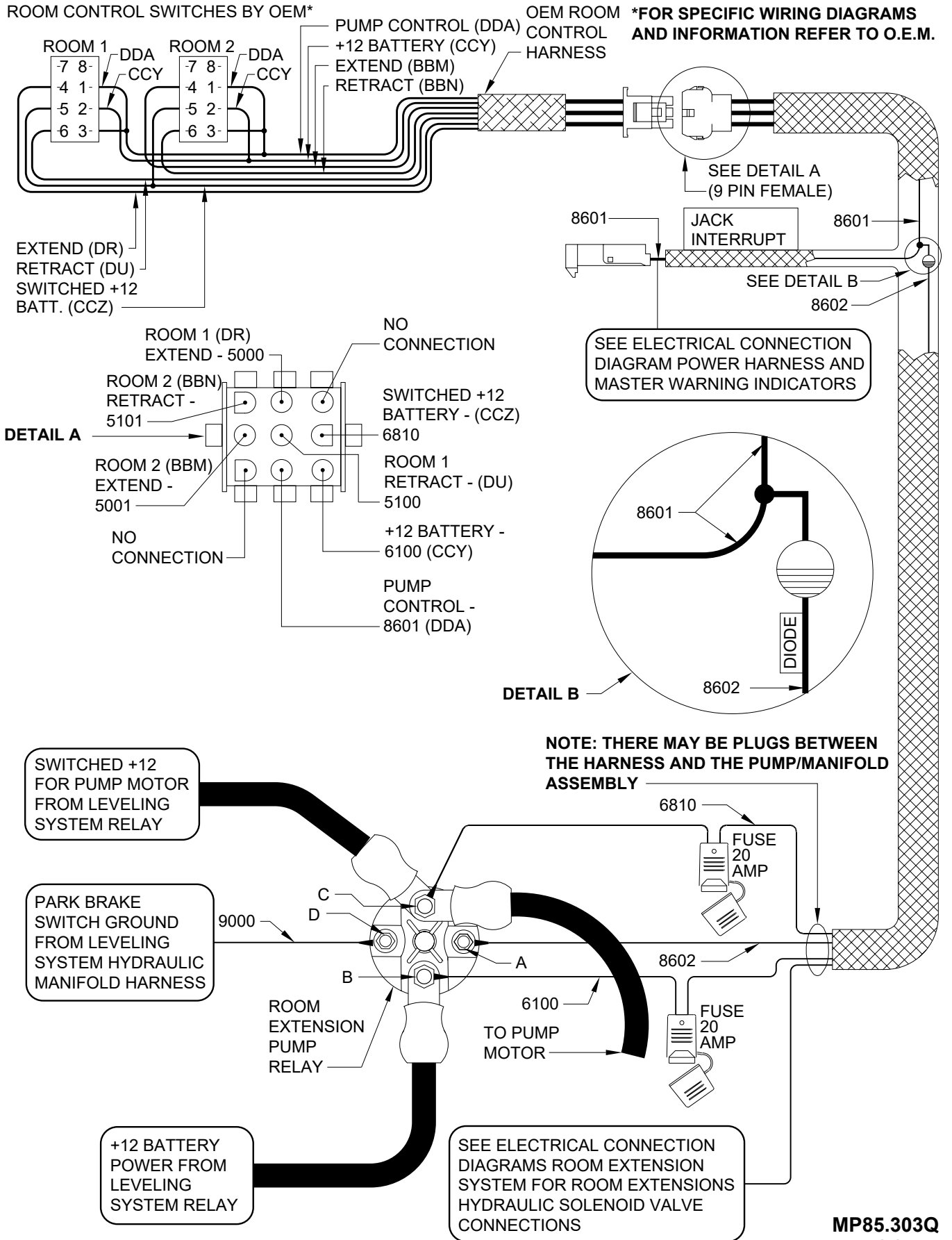

# ELECTRICAL CONNECTION DIAGRAM

## PUMP RELAYS

### 310 SERIES LEVELING SYSTEM WITH ONE OR TWO ROOM EXTENSIONS

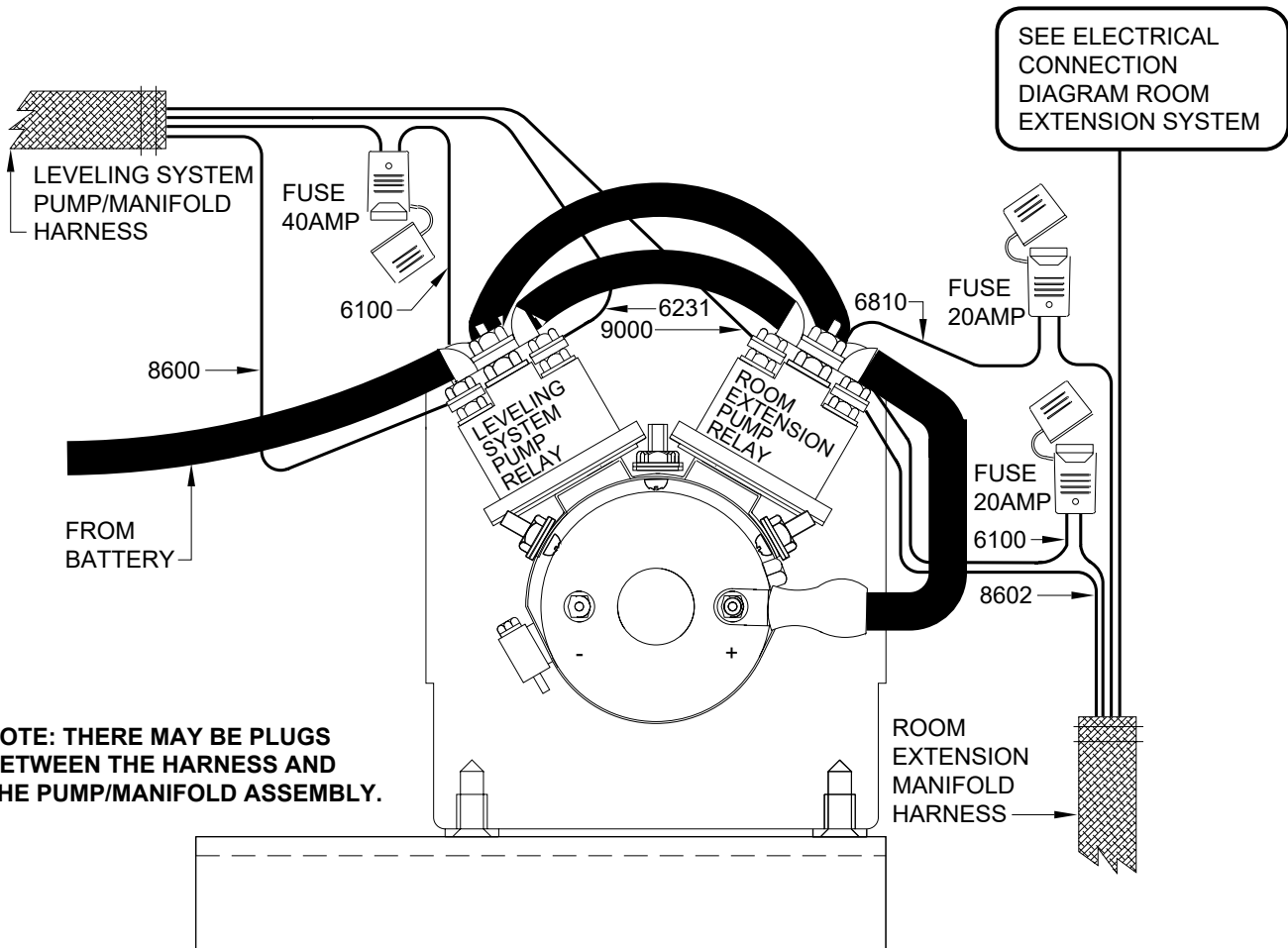
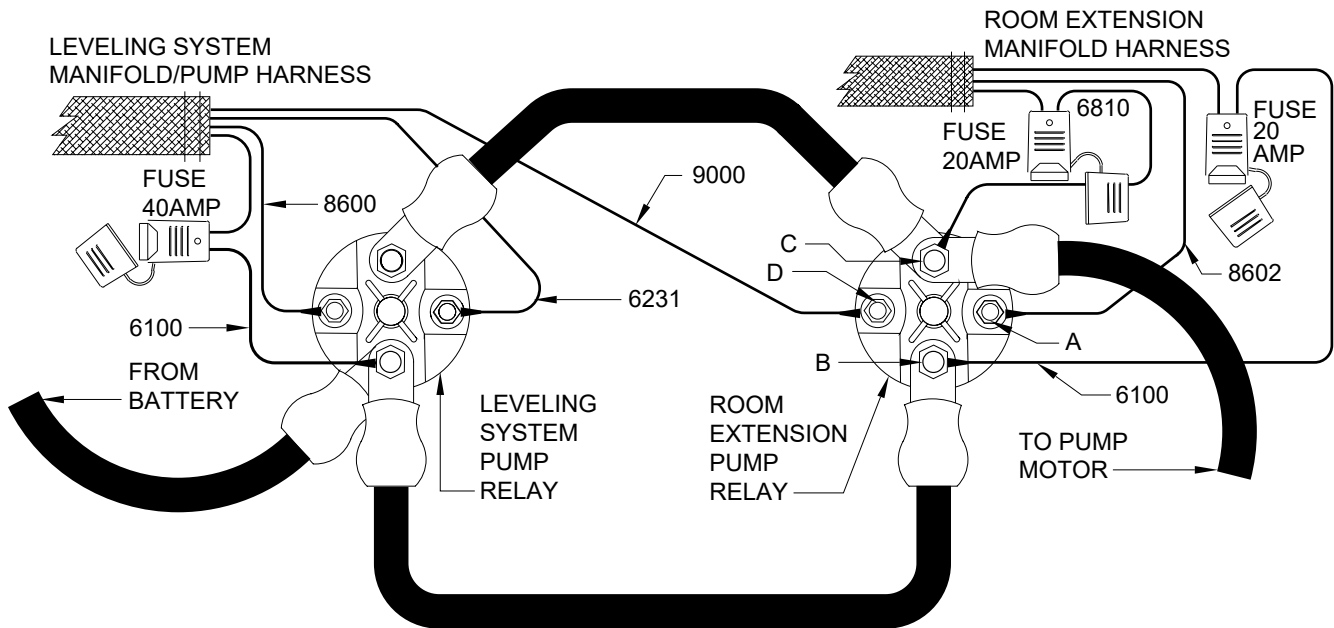

# ELECTRICAL CONNECTION DIAGRAM

## 310 SERIES LEVELING SYSTEM WITH ROOM EXTENSIONS

### POWER HARNESS AND MASTER WARNING INDICATORS

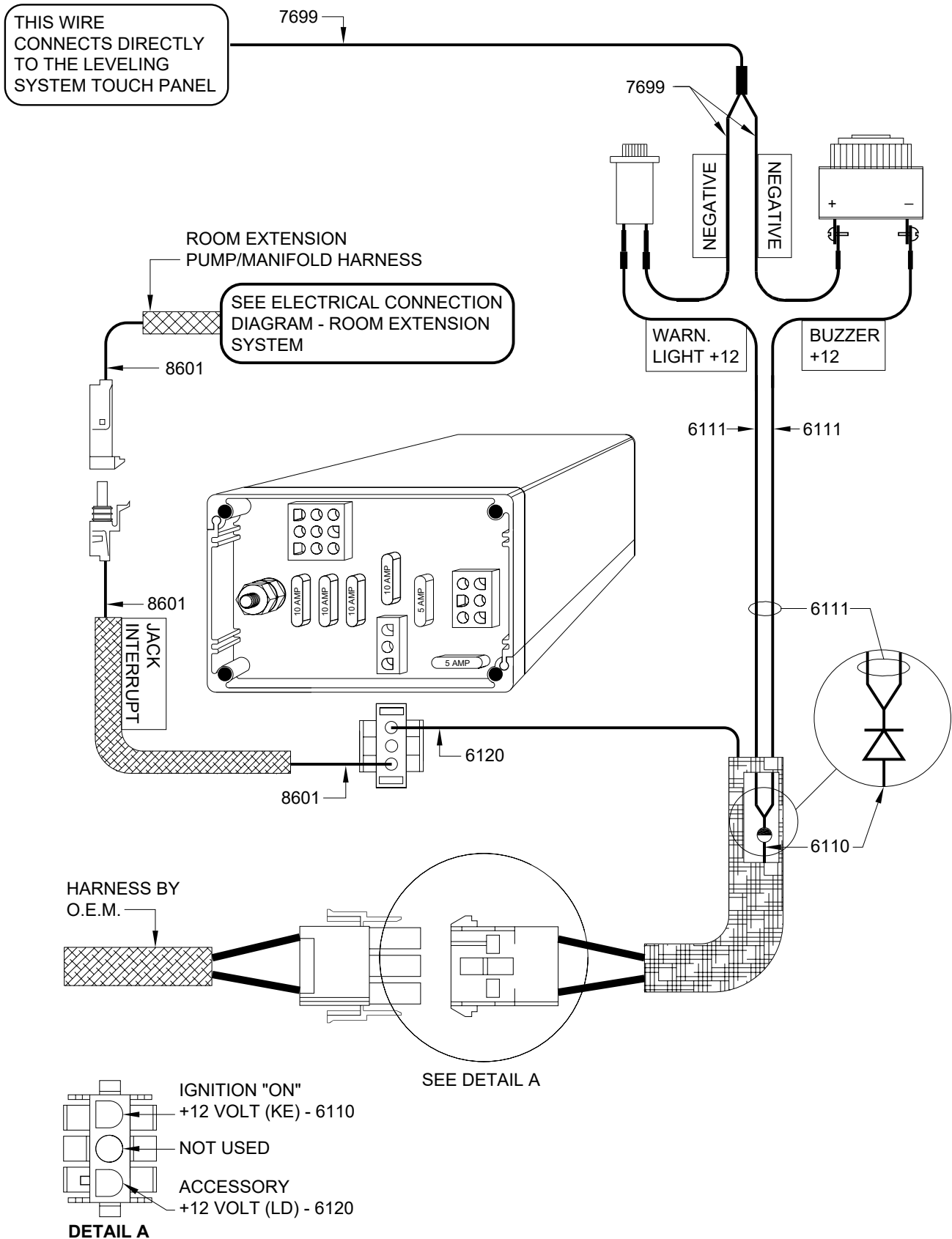

**MP85.304C**  
**180CT00**

SAME AS (MP85324G)

# ELECTRICAL CONNECTION DIAGRAM GROUNDING INSTRUCTIONS

## WELDED PUMP MOUNT

USE GROUNDING STUD AND 3/8" EXTERNAL STAR LOCK WASHERS AS SHOWN.

**IMPORTANT:** STAR LOCK WASHER MUST BE USED BETWEEN GROUNDING SURFACE AND WIRE TERMINALS

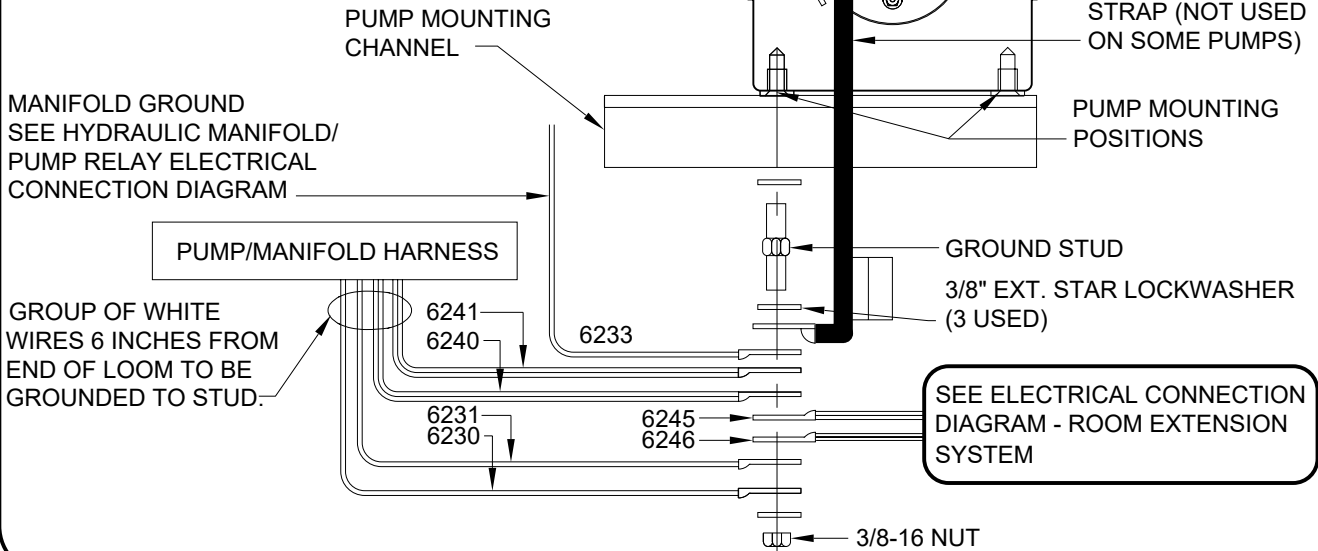

## PUMP MOUNTED REMOTE FROM FRAME

USE GROUNDING STUD AND 3/8" EXTERNAL STAR LOCK WASHERS AS SHOWN.

**IMPORTANT:** STAR LOCK WASHER MUST BE USED BETWEEN GROUNDING SURFACE AND WIRE TERMINALS

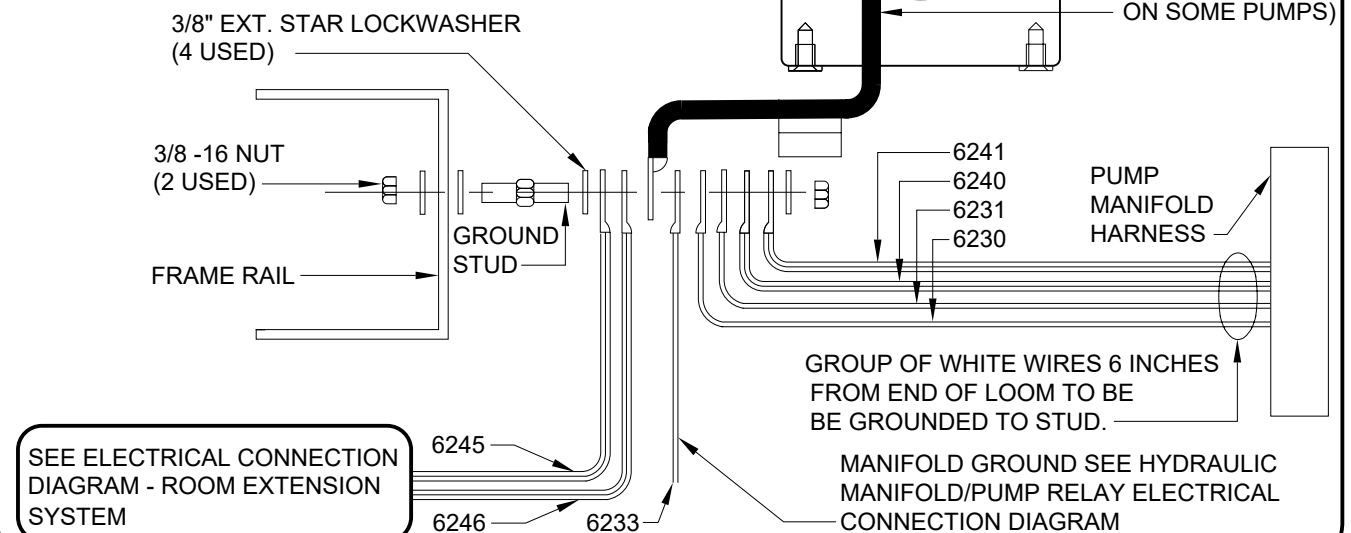



# ELECTRICAL CONNECTION DIAGRAM

## POWER UNIT/MANIFOLD PIGTAIL ASSEMBLY

### WITH TWO ROOM EXTENSIONS AND 310 SERIES LEVELING SYSTEM

COACHES BEFORE MID - YEAR 2000 DID NOT HAVE THE PIGTAIL ASSEMBLY. REFER TO THE DIAGRAMS IN THIS MANUAL FOR CORRECT INFORMATION. COACHES BUILT AFTER MID - YEAR 2000 MAY HAVE THE PIGTAIL ASSEMBLY. COMPONENT CONNECTIONS WILL REMAIN THE SAME. THIS PAGE SHOWS THE PLUG CONNECTIONS FOR THE MAIN HARNESSES.

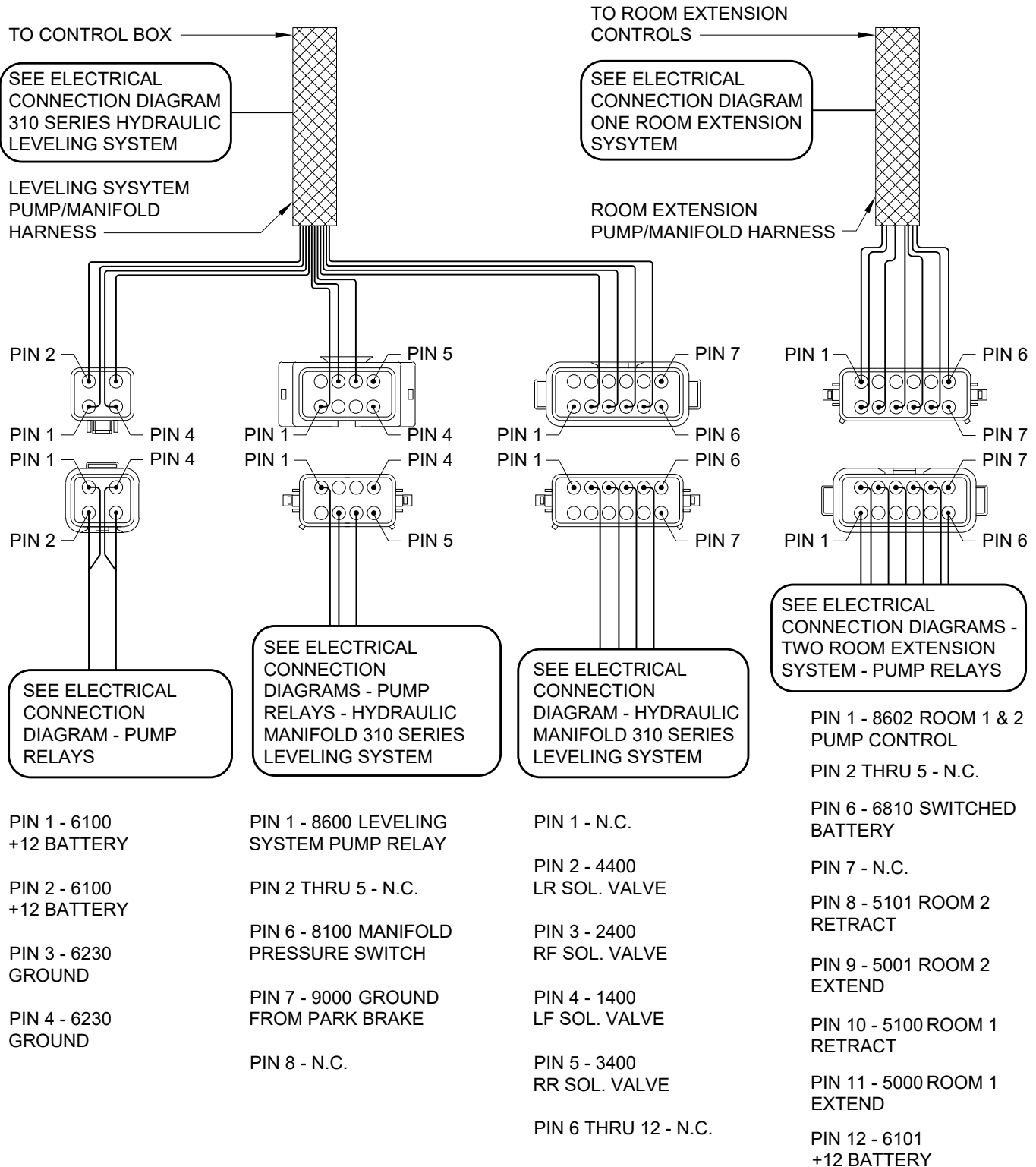

**ELECTRICAL CONNECTION  
DIAGRAMS  
FOR  
COACHES WITH ONE OR TWO  
ROOM EXTENSIONS AND A  
610 SERIES LEVELING SYSTEM**

**(NOT FOR COACHES WITH A FOUR CYLINDER  
ROOM EXTENSION)**

# ELECTRICAL CONNECTION DIAGRAM

## TWO ROOM EXTENSION SYSTEM - 610 LEVELING-SYSTEM

### SOLENOID VALVES WITH VALVE RELEASE "T" HANDLES

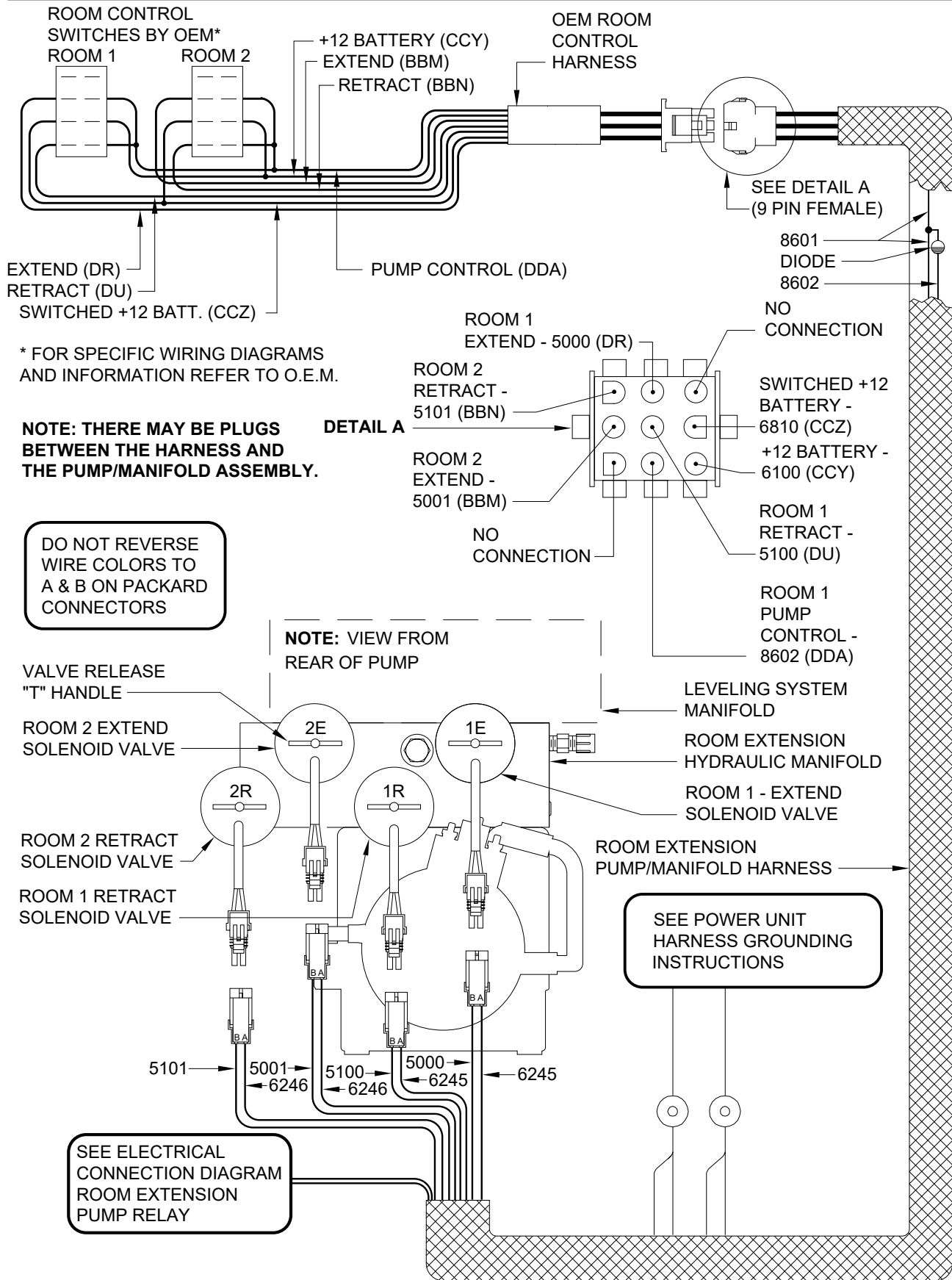

**VIEW FROM PUMP END**

# ELECTRICAL CONNECTION DIAGRAM

## TWO ROOM EXTENSION SYSTEM - 610 LEVELING SYSTEM

### (WITH SOLENOID VALVES WITH VALVE RELEASE NUTS)

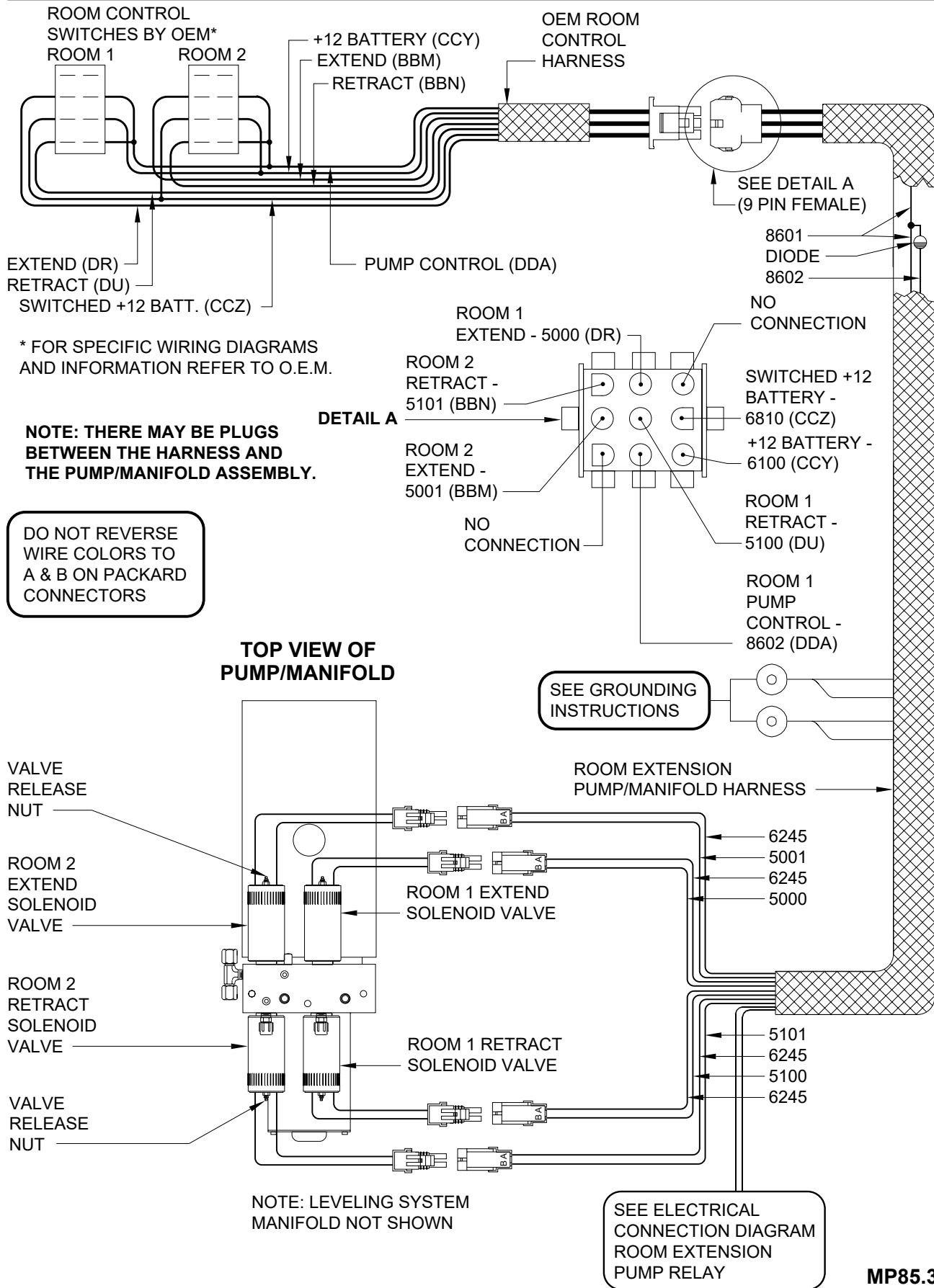

# ELECTRICAL CONNECTION DIAGRAM ROOM EXTENSION PUMP RELAY 610 SERIES LEVELING SYSTEM WITH ROOM EXTENSIONS

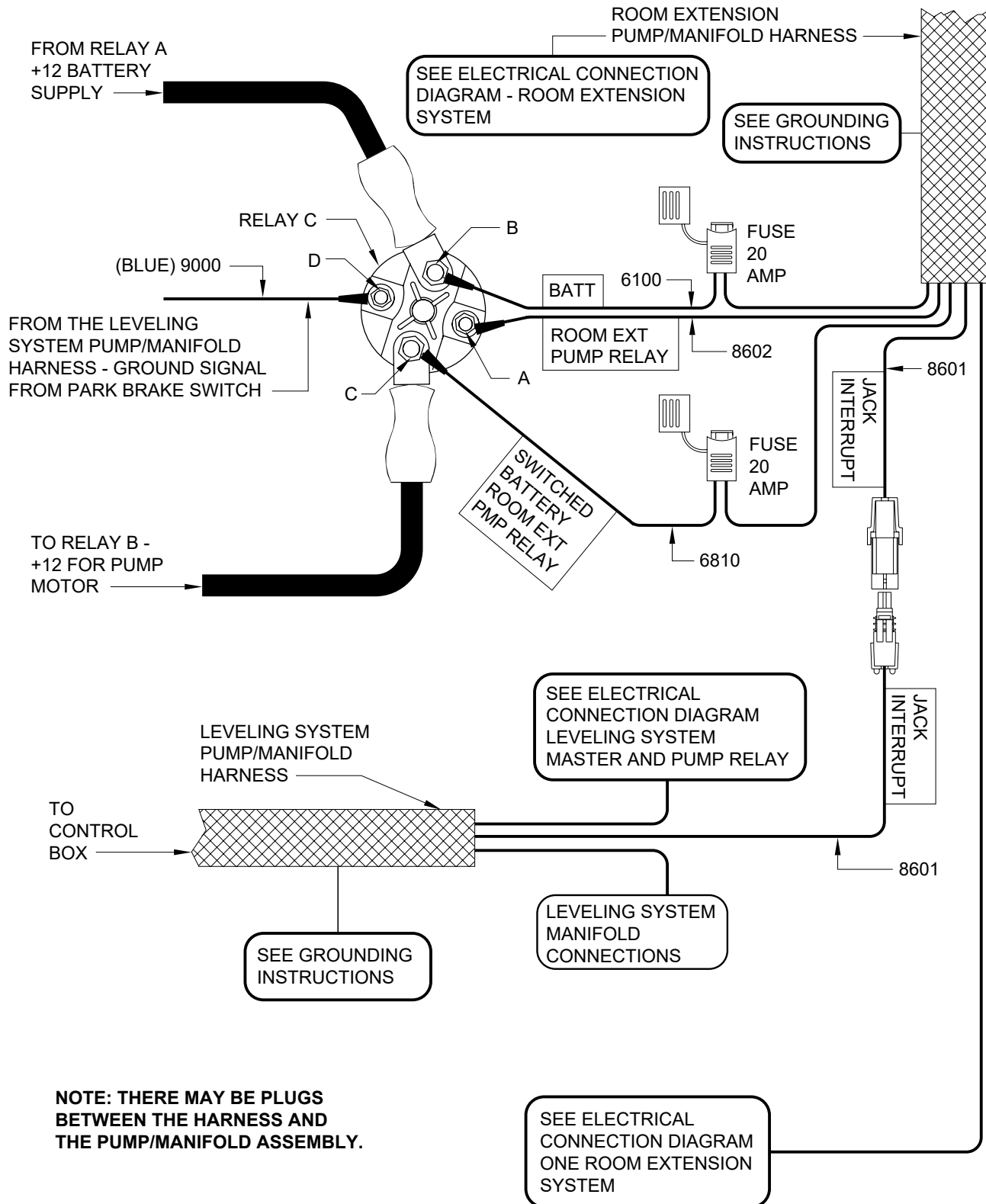

# ELECTRICAL CONNECTION DIAGRAM 610 SERIES LEVELING SYSTEM MASTER AND PUMP RELAY WITH ROOM EXTENSIONS

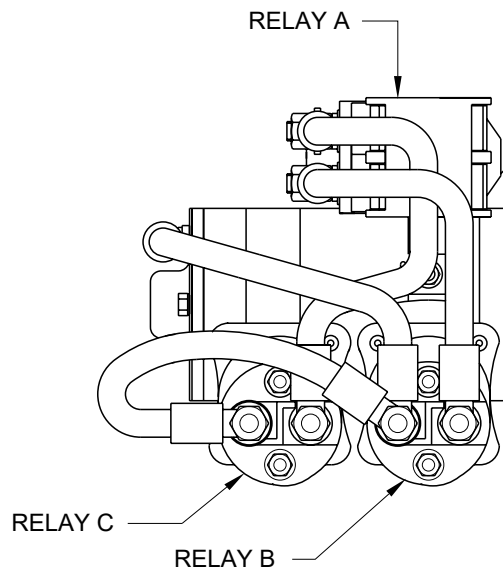
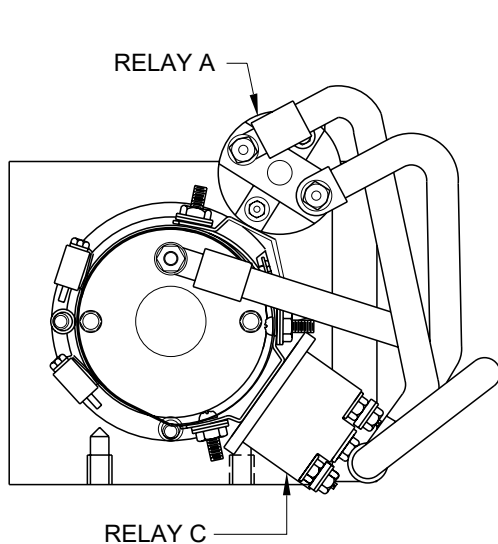
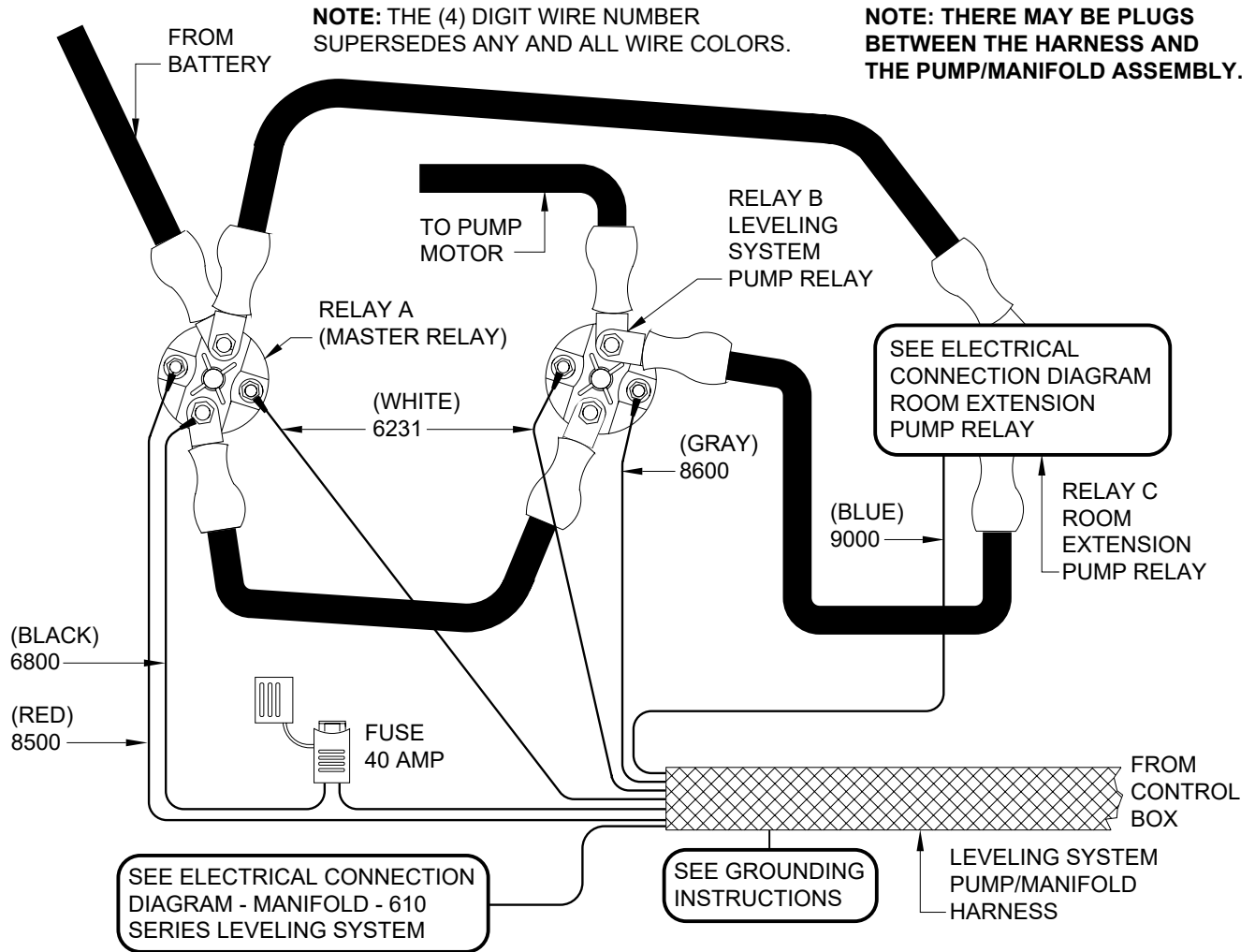

# ELECTRICAL CONNECTION DIAGRAM

## POWER UNIT/MANIFOLD PIGTAIL ASSEMBLY

### 610 LEVELING SYSTEM WITH TWO ROOM EXTENSIONS

COACHES BEFORE MID - YEAR 2000 DID NOT HAVE THE PIGTAIL ASSEMBLY. REFER TO THE DIAGRAMS IN THIS MANUAL FOR CORRECT INFORMATION. COACHES BUILT AFTER MID - YEAR 2000 MAY HAVE THE PIGTAIL ASSEMBLY. COMPONENT CONNECTIONS WILL REMAIN THE SAME. THIS PAGE SHOWS THE PLUG CONNECTIONS FOR THE MAIN HARNESSSES.

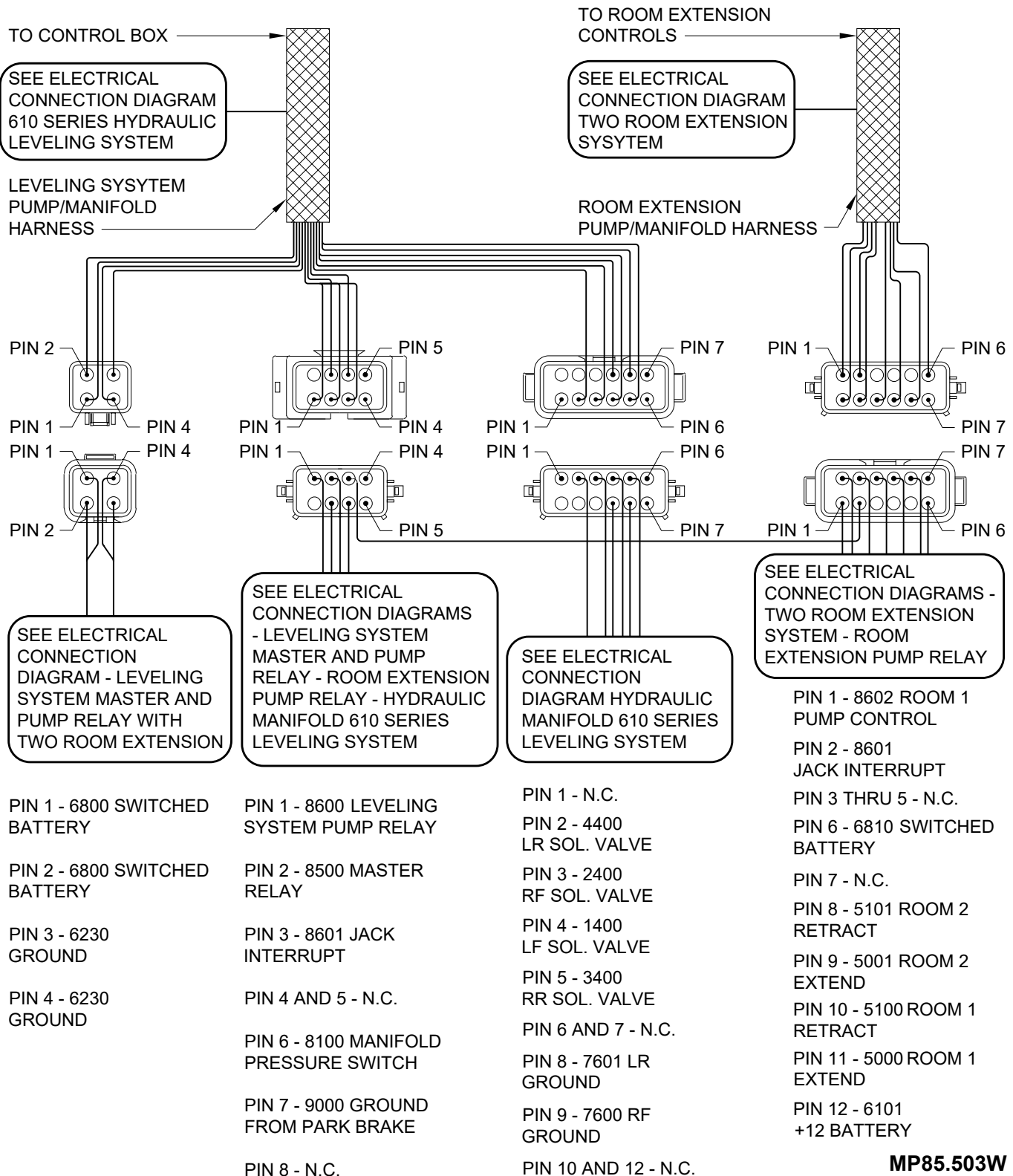

# ELECTRICAL CONNECTION DIAGRAM

## 610 SERIES LEVELING SYSTEM WITH ROOM EXTENSIONS

### POWER HARNESS AND MASTER WARNING INDICATORS

**NOTE:** THE (4) DIGIT WIRE NUMBER SUPERSEDES ANY AND ALL WIRE COLORS.

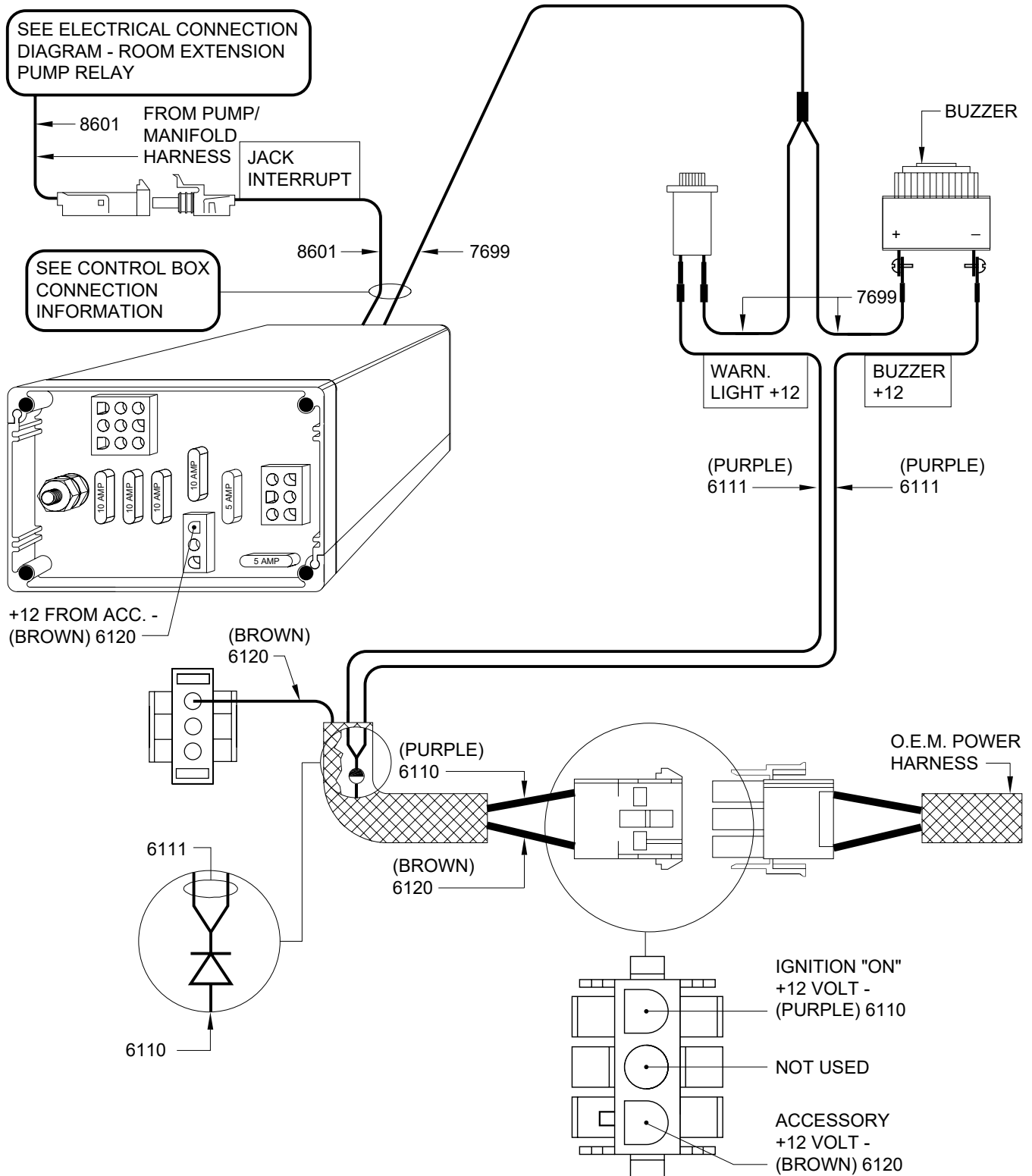



# GROUNDING INSTRUCTIONS

## 610 SERIES LEVELING SYSTEM (WITH ROOM EXTENSION)

### WELDED PUMP MOUNT

USING GROUNDING STUD AND 3/8" EXTERNAL STAR LOCKWASHERS AS SHOWN.

**IMPORTANT:** STAR LOCKWASHERS MUST BE USED BETWEEN GROUNDING SURFACE AND WIRE TERMINALS.

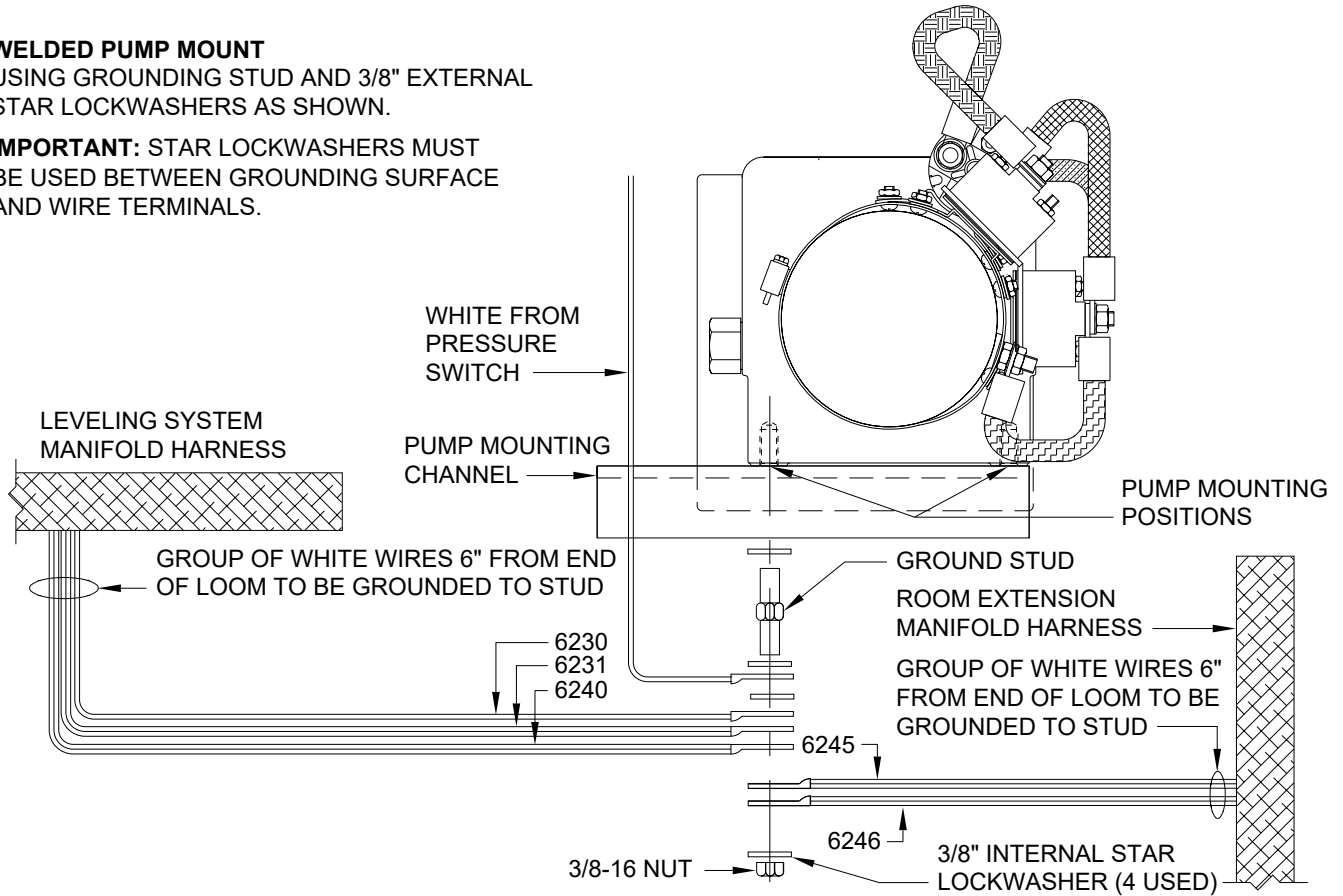

### PUMP MOUNTED REMOTE FROM FRAME

USE GROUNDING STUD AND 3/8" EXTERNAL STAR LOCKWASHERS AS SHOWN.

**IMPORTANT:** STAR LOCK WASHERS MUST BE USED BETWEEN GROUNDING SURFACE AND WIRE TERMINALS.

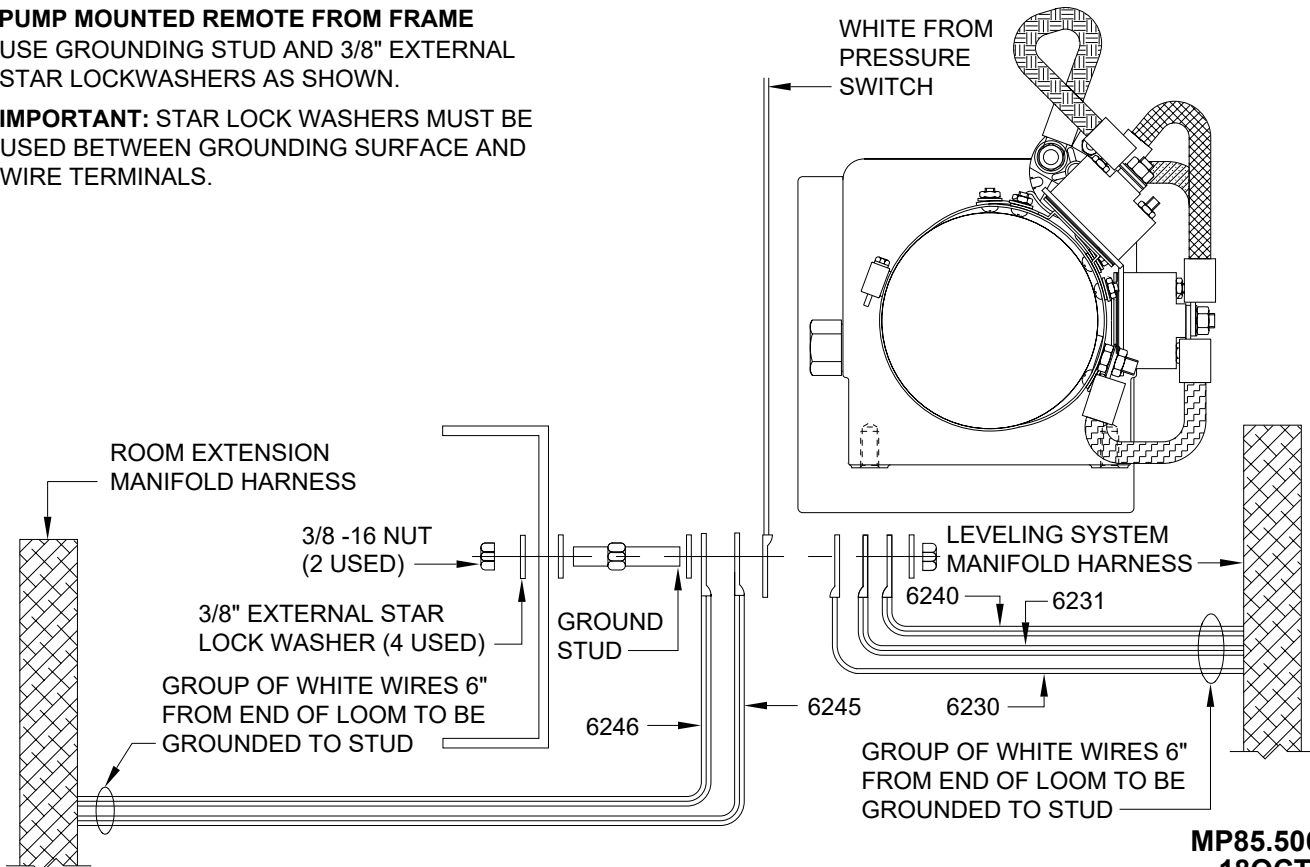

This manual has been provided courtesy of  
My RV Works, Inc.

[www.myrvworks.com](http://www.myrvworks.com)



You can find more RV service manuals here:

[www.myrvworks.com/manuals](http://www.myrvworks.com/manuals)

Over the years of running a mobile RV repair service, having a dedicated place to access service manuals for all the different appliances and components found on RVs was something that I always had a desire to create.

I hope this resource makes your RV repairs easier, as it has mine, but please be careful and follow proper safety practices when attempting to repair your own RV.

If in doubt, please consult with a professional RV technician!



DARREN KOEPP - OWNER, MY RV WORKS, INC.

*All service manuals provided on [www.myrvworks.com](http://www.myrvworks.com) are believed to be released for distribution and/or in the public domain.*