



**HWH<sup>®</sup>**  
**SYNCHRONIZING**  
**CYLINDER**

**HWH CORPORATION**  
(On I-80, Exit 267 South)  
2096 Moscow Road | Moscow, Iowa 52760  
Ph: 800/321-3494 (or) 563/724-3396 | Fax: 563/724-3408  
[www.hwh.com](http://www.hwh.com)

**ML37955/MP65.9911**  
**13APR06**



# HWH SYNCHRONIZING CYLINDER

The synchronizing cylinder is used in most multiple cylinder room extension mechanisms manufactured by HWH Corporation. The cylinder is most often referred to as the SYNC cylinder. **The purpose of the sync cylinder is to keep all the cylinders in a mechanism moving at the same speed.**

There are many issues that can have an effect on the movement of a room extension. Trying to make two cylinders move at the same speed, even when not attached to anything, can be difficult. Adding a room to the equation compounds these issues. Hose size and routing techniques can cause problems. The weight of the room from end to end or top to bottom is a major problem. Even the manufacturing of the cylinders due to manufacturing tolerances will create problems. Other things such as room seals or wipers and room awnings will add to the problem.

The theory behind the sync cylinder is really very simple. If you make the same volume of fluid move at the same rate of flow to or allow coming from the each cylinder in the mechanism, all cylinders in that mechanism have to move the same distance at the same speed. The hydraulic property that allows this to be possible is that fluid, for practical purposes, cannot be compressed. **If you put the exact same volume of fluid into each cylinder of the exact same diameter, those cylinders will move the exact same distance. If the fluid is put in the cylinders at the same rate of flow, those cylinders will move at the same speed.**

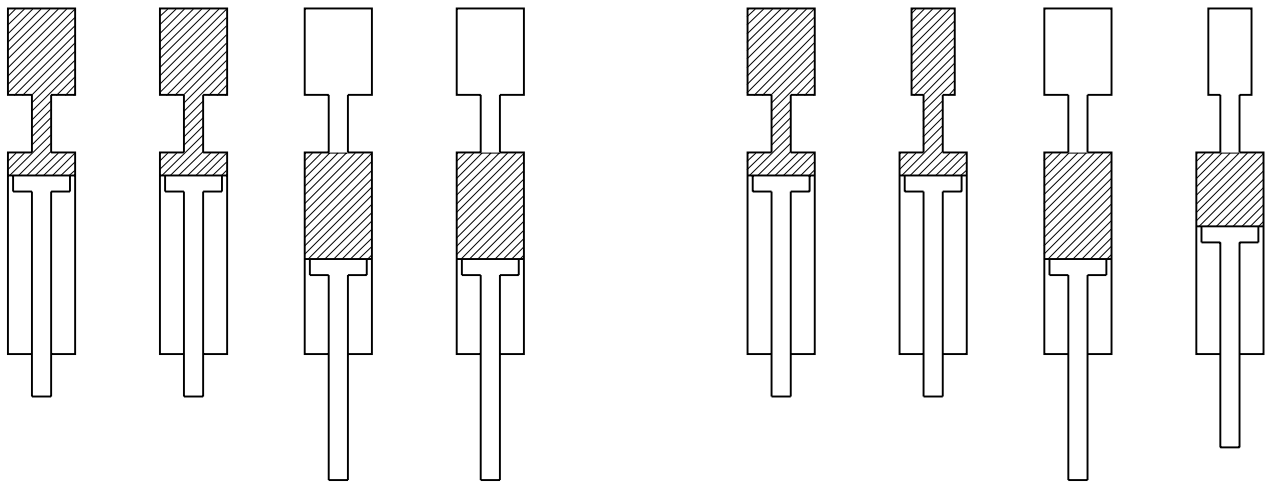

**SAME AMOUNT - SAME DISTANCE**

**DIFFERENT AMOUNT - DIFFERENT DISTANCE**

The sync cylinder is actually several cylinders all tied together in one unit. There is one cylinder or chamber in the sync cylinder for each room mechanism cylinder. There is a piston in each chamber to move the fluid. The pistons are tied together with a rod. When one piston moves, the other piston has to move the exact same distance at the same speed. The "cap" sides of the sync cylinder pistons are tied together hydraulically. The rods connecting the pistons are hollow, which allows fluid to flow, to or from the cap sides of the sync cylinder pistons. The rod sides of the sync cylinder pistons are isolated. **When the sync cylinder moves, the same volume of fluid has to move to or from the rod sides of the sync cylinder. The room mechanism cylinders have to move the same distance at the same speed.**

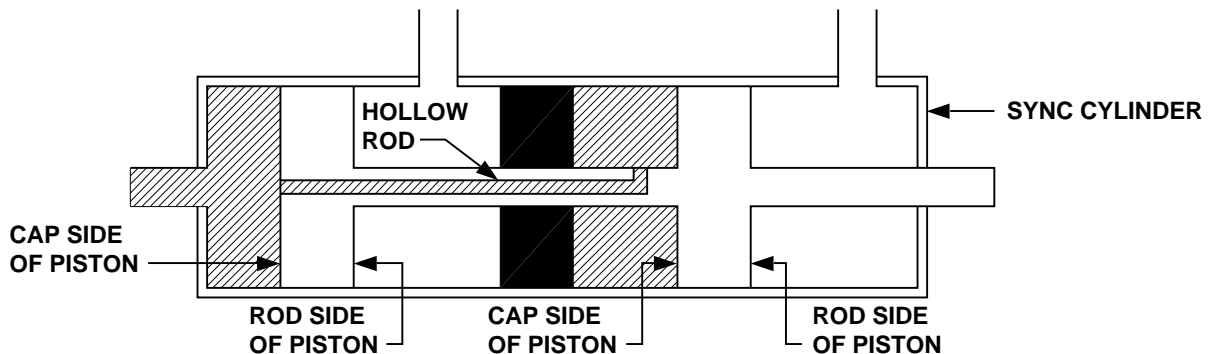

# HWH SYNCHRONIZING CYLINDER

Note the sync cylinder is connected to the rod end of the room cylinders. When the room cylinders are extended, fluid is forced from the rod end on the room cylinders to the sync cylinder. The sync cylinder retracts as the room cylinders extend. When the room cylinders are retracted, the manifold directs fluid to the cap end of the sync cylinder. The sync cylinder pushes fluid to the rod end of the room cylinders. This retracts the room cylinders. **The sync cylinder extends when the room cylinders are retracting.**

HYDRAULIC FLOW DIAGRAM  
VERTICAL ARM OR DUAL CYLINDER ROOM EXTENSION  
WITH SYNCHRONIZING CYLINDER  
STATIONARY POSITION

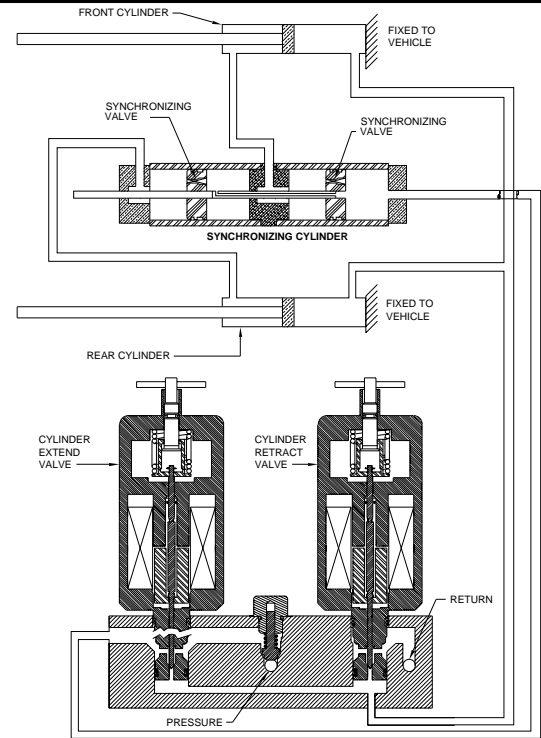

HYDRAULIC FLOW DIAGRAM  
VERTICAL ARM OR DUAL CYLINDER ROOM EXTENSION  
WITH SYNCHRONIZING CYLINDER  
EXTEND POSITION

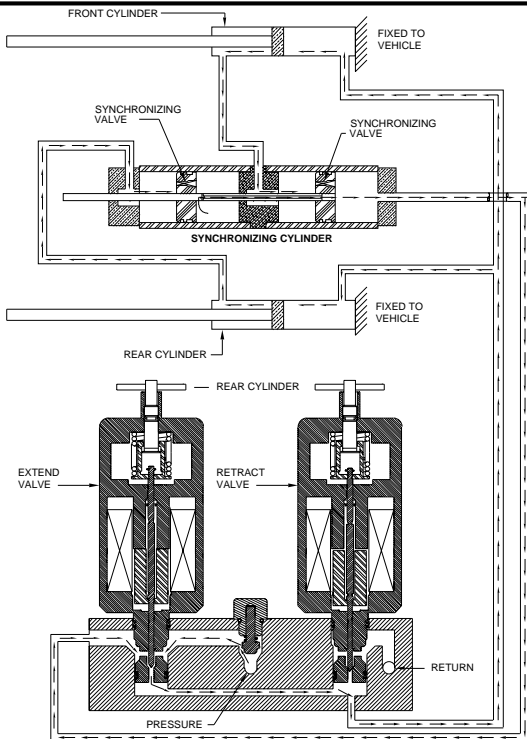

HYDRAULIC FLOW DIAGRAM  
VERTICAL ARM OR DUAL CYLINDER ROOM EXTENSION  
WITH SYNCHRONIZING CYLINDER  
RETRACT POSITION

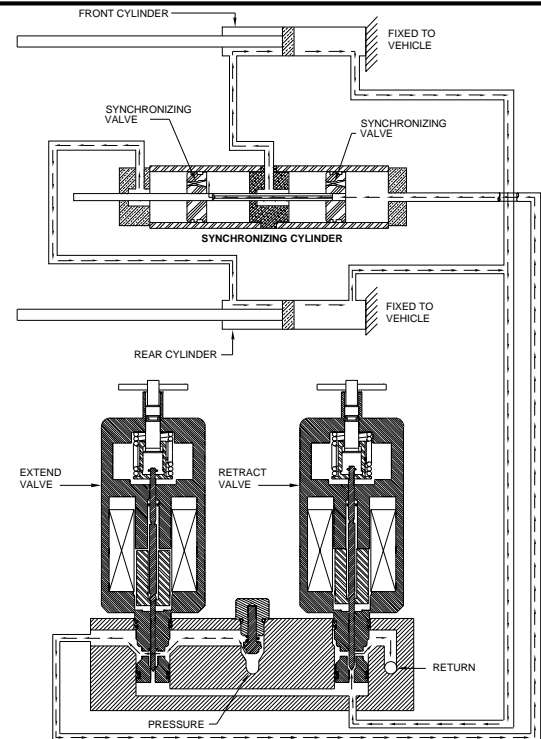

# HWH SYNCHRONIZING CYLINDER

The use of the sync cylinder does create several issues that must be addressed. The first one deals with hose type and lengths. **The hose HWH uses has the capability to expand slightly. Different types of hose HWH uses have different rates of expansion.** This type of hose is used to accommodate an increase in the volume of fluid in the system which can be caused by thermal expansion. The following diagram shows the proper hose arrangement for a two cylinder room mechanism.

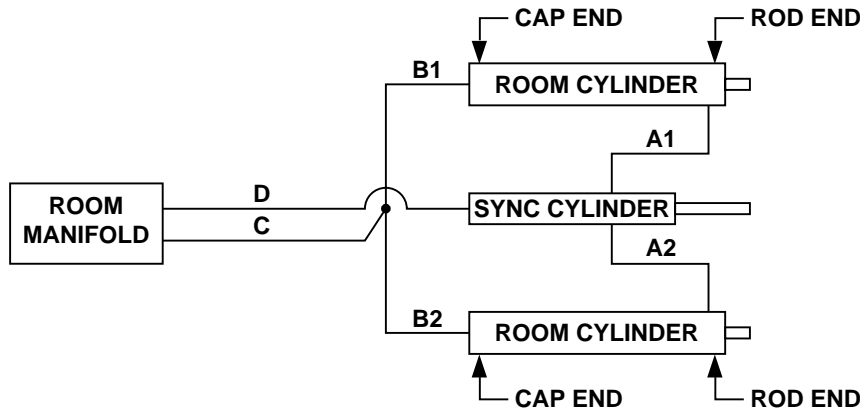

**The hoses from the sync cylinder to the rod end of the room cylinders, A1 and A2, must be the same length, diameter and type of hose. The hoses from the cap end of the room cylinders, B1 and B2, to where they tee together must be the same length, diameter and type of hose.** Although the lengths of the hoses are critical, there is some allowable tolerance in the lengths. This would allow the repair of a hose such as replacing a hose end. The hoses supplying the cap side of the cylinders, C, and the sync cylinder, D, have no restrictions on length, diameter or type. When a room mechanism has four cylinders, two upper and two lower, the situation is dealt with as if there are two rooms. The upper cylinders are plumbed as one room and the lower cylinders are plumbed as another room. The following diagram shows the proper arrangement.

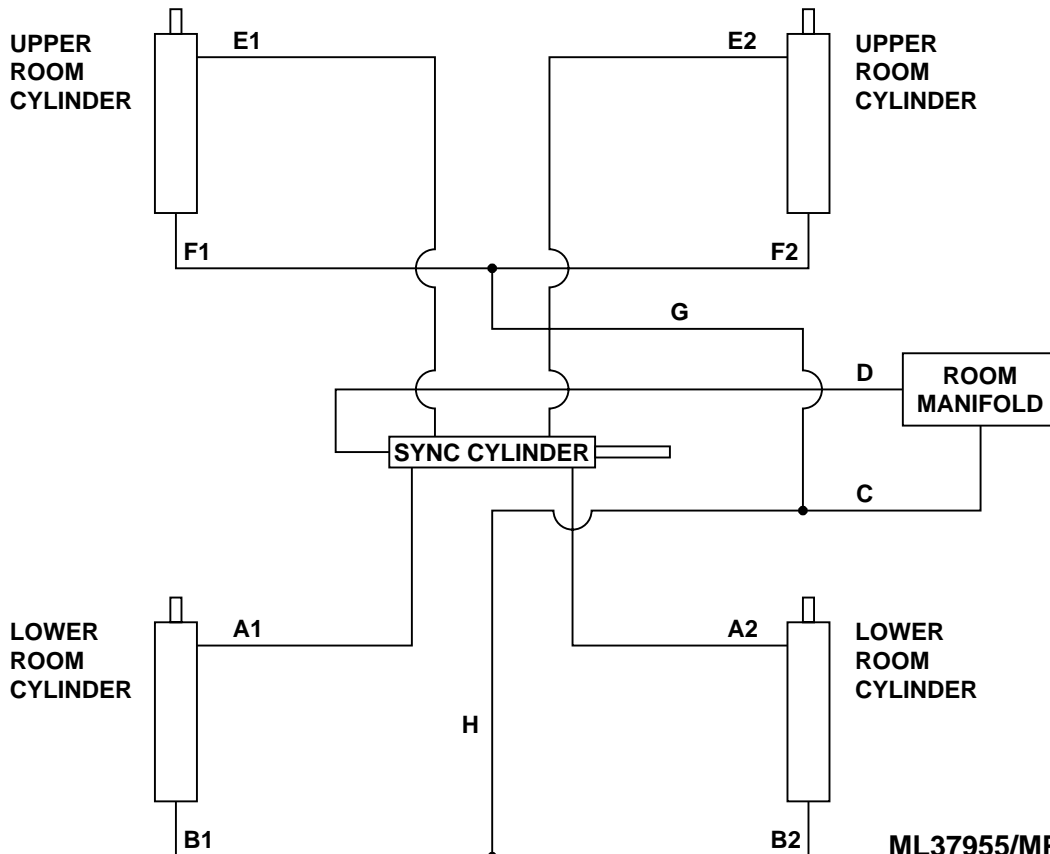

## HWH SYNCHRONIZING CYLINDER

The second issue that must be dealt with has to do with possible large increases in pressure between the sync cylinder and the rod end of the room cylinders when there are certain room malfunctions. **For this reason it is necessary to use a high pressure hose between the sync cylinder and the rod end of the room cylinders.** First, due to the use of the regenerative hydraulic circuit, this issue will only happen when the room cylinders are being retracted. With the regenerative circuit there is pressure on both sides of the room and sync cylinder pistons when the cylinder is extending. The problem occurs when one room cylinder stops moving, for any reason, before both room cylinders are fully retracted. When one room cylinder stops early, the other room cylinder can still move, but the sync cylinder also stops because the fluid moving from the sync cylinder to the room cylinder that has jammed has no where to go. Because the two pistons in the sync cylinder are tied together, the pump pressure in the system is pushing against the cap side of both pistons, this about doubles the force trying to push the jammed room cylinder. Basically, the system pressure is multiplied by two between the sync cylinder and the rod side of the jammed room cylinder [ $P$  (pressure) =  $F$  (force)  $\div$   $A$  (area)].

Sync piston - 1.50"d or 1.766 sq. in. [Area 1]

Sync rod - 0.5625"d or 0.248 sq.in.

Sync piston less rod area - 1.518 sq. in. [Area 2]

Pump pressure - 3500 psi.

Resistive pressure - 1000psi. [This figure is approximate and differ in each system.]

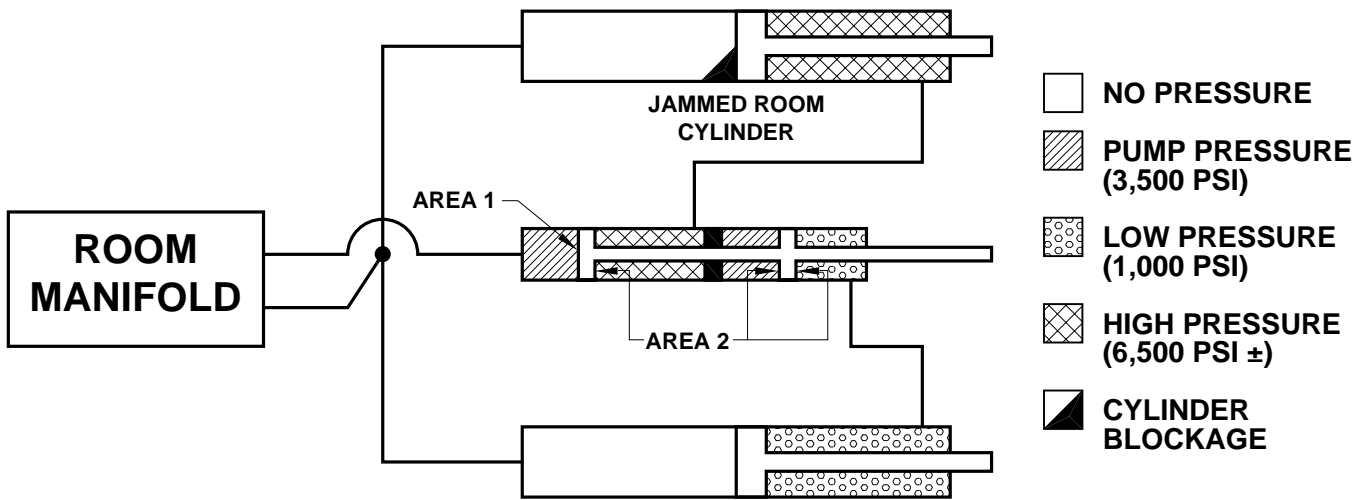

There are two pistons pushing on the jammed cylinder creating the high pressure. Even though the other cylinder is not jammed, due to weight and friction factors there is a lower pressure on the rod side of the free cylinder creating a resistive force in the sync cylinder. The force on the jammed cylinder is the combined area of the cap side of the sync cylinder pistons times the pump pressure.  $3,500 (P) \times 3.284 (A [1.766 + 1.518]) = 11,494$  lbs. of force. This is resisted by the force on the rod side of the free cylinder. The force on the rod side of the free cylinder is pressure remaining on the rod side of the free cylinder times the area of the rod of the sync cylinder piston.  $1,000 (P) \times 1.518 (A) = 1,518$  lbs. of force. The net force on the rod side of the jammed piston is 11,494 lbs. less the resistive force of 1,518 lbs. or 9,976 lbs. of force. The pressure on the rod side of the jammed cylinder is  $9,976 (F) \div 1.518 (A) = 6,572$  psi.

# HWH SYNCHRONIZING CYLINDER

The high pressure situation is even more critical in a system that contains four room cylinders controlled by one sync cylinder. In this system, a jamming malfunction of a room cylinder can cause the pressure in the rod side of the jammed room cylinder to approximately quadruple the pump pressure. This is because there is a piston for each room cylinder, thus four pistons in the sync cylinder. In these systems the sync cylinder is equipped with 5,000psi pressure switches. Note: some four cylinder sync cylinders may have 4,000psi pressure switches. These are replaced, when necessary, with the 5,000psi pressure switches. If the pressure in the system reaches 5,000psi, the pump will shut off. **IT IS VERY IMPORTANT THAT A ROOM EXTENSION OPERATED WITH THIS TYPE OF SYNC CYLINDER IS NEVER OPERATED WITH ANY OF THE PRESSURE SWITCHES UNPLUGGED.** Serious damage can occur to the system components if this happens.

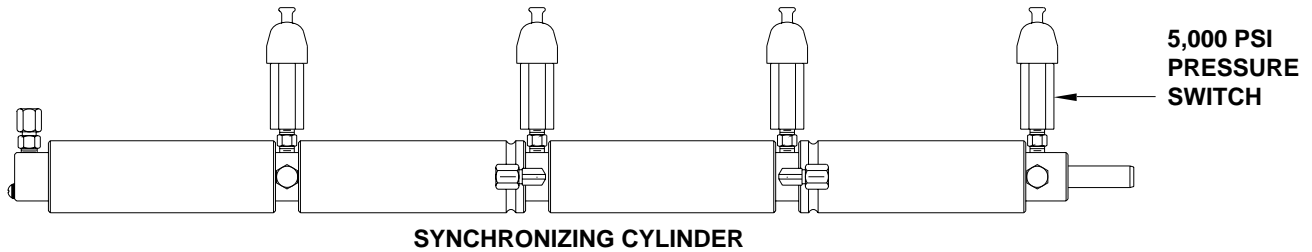

A third issue that can happen deals more with the installation of the system, but can create operational problems with the system that must be dealt with. First, because the sync cylinder is normally mounted exposed on the frame of the vehicle and is extended when the room cylinders are retracted, painting or undercoating of the frame without protecting the sync cylinder rod can coat the exposed rod of the sync cylinder. This will damage the seals of the sync cylinder if the room is operated before the rod is cleaned. Another problem can be the mounting location of the sync cylinder. Any obstruction that the sync cylinder rod may contact during operation may cause damage to the sync cylinder.

## SYNCHRONIZING VALVES

Another feature of the sync cylinder is the synchronizing valve in each sync cylinder piston. **Due to many factors such as manufacturing tolerances when constructing the room itself, weights and seals, rooms with multiple cylinders can have slight difference in movement from end to end when extending or retracting.** Because of this, a room can become "unsynchronized" with repeated use. The more the room becomes unsynchronized the more erratic the operation of the room becomes. The synchronizing valves in the sync cylinder pistons correct this problem. The synchronizing valve is a poppet on each side of each sync cylinder piston. When the sync cylinder is fully extended or retracted, these poppets open, tying the "cap" and "rod" side of each piston together allowing the fluid to flow through the piston. One poppet is pushed open mechanically when the sync cylinder reaches full stroke, extending or retracting, while the other poppet is opened with hydraulic pressure. Because the "cap" side of each piston is tied together through the hollow connecting tube, all the chambers in the sync cylinder are tied together hydraulically. Basically, the sync cylinder becomes a tee, allowing the fluid to flow as needed, the path of least resistance, to fully extend or retract the room extension.

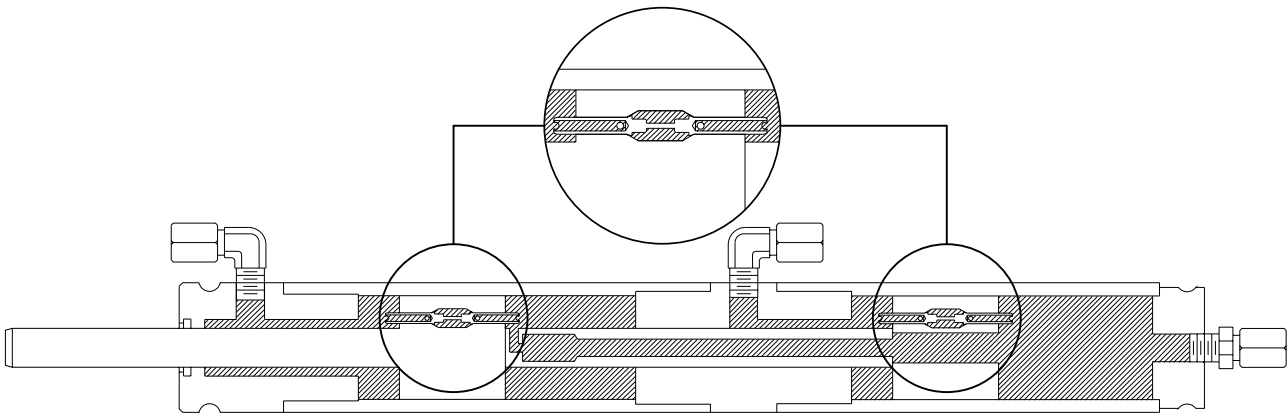

**The sync cylinder has to be precisely matched to the actual stroke of the room, not the room cylinders.** If the sync cylinder has too long of a stroke, the poppets can not open. The room will become unsynchronized, possibly to the point the room will jam up and not move. If the sync cylinder has too short of a stroke, the poppets will open too soon. The room will operate unsynchronized. The movement of the room becomes erratic and can "walk" or "rack" as it extends or retracts.

---

## HWH SYNCHRONIZING CYLINDER

---

Although the sync cylinder allows the room to be sealed properly when extended or retracted, there are different movement characteristics that can occur, such as one side of the room may start to extend slightly before the other. One side of the room may not be fully extended at the same time as the other, but will then become fully extended. These are common occurrences and should not be considered a problem or malfunction. No two mechanisms or rooms will run perfectly the same. Even the same type of mechanism on the same vehicle may exhibit different operational characteristics. **As long as the room runs fairly smooth while moving, seals properly at both ends of the room when fully extended or retracted and there is no apparent damage to room seals, flooring, ceilings, walls etc., the room should be considered operating properly.**

The diagnostic issues caused by the sync cylinder are directly related to its functions. The sync cylinder is used to make the room run fairly smooth and to allow the room to properly seal when extended and retracted. Because the sync cylinder uses isolated chambers to move equal amounts of fluid to and from the room cylinders, a problem with the sync cylinder piston seals or piston poppets can allow unequal movement of fluid. This may result in the room "racking" or one side of the room lagging behind when moving. This symptom may also be caused by other problems such as room adjustments and mechanism or room cylinder malfunctions. Usually the hoses between the sync cylinder and the room cylinders can be swapped at the sync cylinder. If the problem is the sync cylinder, the symptom will move to the other side of the room. **If the mechanism uses four room cylinders, do not cross an upper and lower hose. Only swap upper or lower hoses together.**

Another problem encountered with rooms is creeping problems. In most cases the sync cylinder can not cause a room to creep in or out. **But, if the sync cylinder has a visible oil leak, this can cause a room cylinder to creep out.** When the room cylinders are retracted, pressure on the rod side of the room cylinders keep the cylinders retracted. When the sync cylinder leaks (visibly) this reduces the pressure holding the room cylinder(s) in. This allows the cylinder(s) to creep out.

**The most significant problem that must be dealt with that involves the sync cylinder has to do with air that may be trapped in the system.** HWH room cylinders are operated with a regenerative hydraulic circuit. (See HWH REGENERATIVE HYDRAULIC CIRCUIT-ML37939) When a regenerative circuit is used there is pressure on both sides of the room cylinder piston(s) when the cylinder is extended. With the sync cylinder involved, there are multiple chambers in the system that are isolated from each other. **Air is very compressible, hydraulic fluid is not. If air is trapped in one chamber, this can cause very erratic movement in the room including one side moving in while the other side moves out. The room can become severely racked.** When this occurs, the solution may involve removing hoses to bleed the system along with disconnecting the mechanism from the room which can be an extremely involved situation.

When replacing parts in a hydraulic system, air will be introduced into the system. **If proper bleeding procedures are followed, it reduces the possibility of racking problems when the room is operated.** There are two main things to start with when bleeding a system with a sync cylinder. First, the sync cylinder must be fully retracted before running the system. Second, all room cylinders in the mechanism must be disconnected from the mechanism. If easier, disconnect the mechanism from the room. When the replacement of the parts is complete, the first operation of the room should be to extend the room cylinders. The hose from the sync cylinder should be disconnected from the manifold and directed into the fluid reservoir. The manifold fitting must be capped with a steel cap. This allows the cylinders to be extended without pressure on the rod side of the room cylinders. This allows fluid and air to move out of the system without being under pressure. **Hold the room control switch to extend the room cylinders until all room cylinders in the mechanism are fully extended. Continue to hold the switch for about five seconds.** This assures the sync cylinder poppets will open and allow fluid and air to move through the system. When all room cylinders are fully extended, reattach the sync cylinder supply hose to the manifold. Extend and retract the room cylinders several times until the room cylinder rods are moving together. Reattach the cylinders to the mechanism. Reattach the mechanism to the room if it was disconnected. Extend and retract the room several times to assure proper operation of the room. **When extending and retracting the cylinders or room always continue to hold the room control switch for several seconds after the cylinders or room is fully extended or retracted. When extending or retracting the room always pay close attention to the operation of the room. If the rooms starts to rack or is not operating properly, release the room control switch immediately.**



---

# HWH SYNCHRONIZING CYLINDER

---

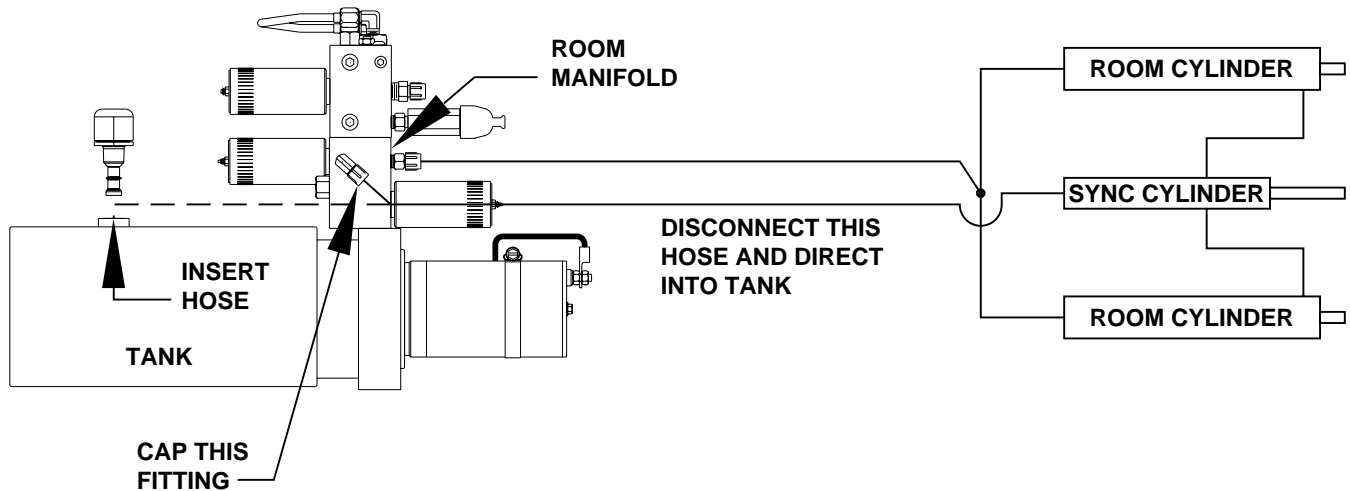

When replacing a sync cylinder in the system the room cylinders should be fully retracted before the repair is made. Because the new sync cylinder will be retracted when installed, this will allow the room cylinders to be extended with the sync cylinder retracted.

When replacing a room cylinder the room cylinders should be fully extended before replacing the room cylinder. The new room cylinder will be retracted when installed. This allows the new cylinder to be extended with the sync cylinder retracted.

**Whenever a proper bleeding procedure is followed when repairing a room mechanism and the room racks or cannot be made to operate properly, contact HWH Customer Service for assistance before continuing.**

There are several simple instructions that need to be followed when operating the room under normal conditions.

1. Make sure there is adequate room to fully extend the room. Make sure people and objects are clear of the room while operating the room. Make sure pets are accounted for before operating the room.
2. Always fully extend or retract the room. **Do not run the room back and forth in the middle of the stroke.** If the movement of the room must be reversed in the middle of the stroke, completely extend or retract the room as needed to restart the operation. When the room is operated in the middle of the stroke without fully extending or retracting, the synchronizing poppets in the sync cylinder cannot open. This can cause the room to become unsynchronized and possibly become jammed up. It is allowable to stop the operation of the room and then continue as long as the movement of room is not reversed.
3. Always hold the room control switch for several seconds after the room is fully extended or retracted. This assures the room cylinders will be properly pressurized and the synchronizing poppets open to resynchronize the room.
4. **The most important instruction is to pay attention to the operation of the room.** If the room malfunctions while operating, the sooner the operation is halted, there will be less damage that can occur to the room and/or room mechanism.

Finally, there can be different styles of synchronizing cylinders. They may be physically different or the internal parts of the cylinder may be different. The important thing to understand is principals and features of the sync cylinder discussed in this publication will be the same in other sync cylinders.

This manual has been provided courtesy of  
My RV Works, Inc.

[www.myrvworks.com](http://www.myrvworks.com)



You can find more RV service manuals here:

[www.myrvworks.com/manuals](http://www.myrvworks.com/manuals)

Over the years of running a mobile RV repair service, having a dedicated place to access service manuals for all the different appliances and components found on RVs was something that I always had a desire to create.

I hope this resource makes your RV repairs easier, as it has mine, but please be careful and follow proper safety practices when attempting to repair your own RV.

If in doubt, please consult with a professional RV technician!



DARREN KOEPP - OWNER, MY RV WORKS, INC.

*All service manuals provided on [www.myrvworks.com](http://www.myrvworks.com) are believed to be released for distribution and/or in the public domain.*