

Technical Service Support

Table of Contents

General

1. Equalizer Systems [Warranty](#) Policy
2. Overview of the AutoLevel™ / AutoAir™ [Control Panel](#)
3. Setting the [Null](#)

AutoLevel™ Jack System

1. General [System](#) operation
2. [Troubleshooting](#) Guide
3. Component [Drawings](#)
4. Manual [Override](#) Procedure

AutoAir™ System

1. General [System](#) operation
2. [Troubleshooting](#) Guide
3. Component [Drawings](#)

For additional support contact us at service@equalizersystems.com

Equalizer Systems
P.O. Box 668, 55169 CR 3 North
Elkhart, IN 46515
Phone: (574) 264-3437 Fax: (574) 266-6083

Basic System Components

Note

Some components may be located differently

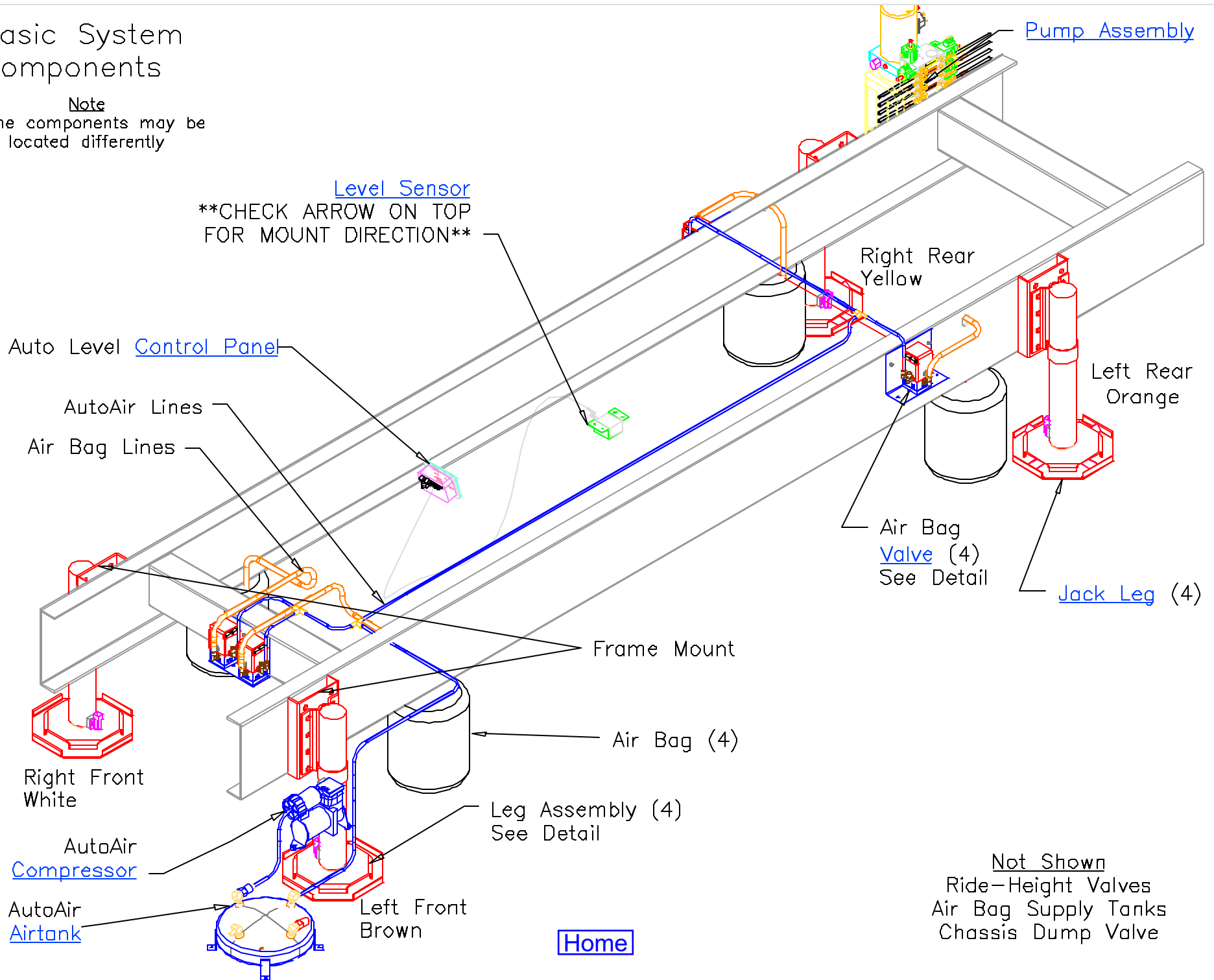

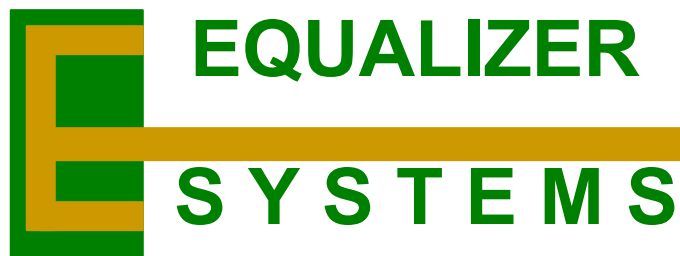

WARRANTY

The Equalizer System shall have the following warranty coverage:

100% parts coverage for all defective parts for a period of three (3) years and 100% labor coverage for replacement of any defective parts, including shipping, for a period of one (1) year. This warranty period shall begin on the date when the Equalizer System enters into service. If the part is found to be defective, Equalizer Systems shall pay parts and shipping expense for the defective part for a period of one year. Equalizer Systems reserves the right to authorize repair, parts, replacement, shipping costs, and/or any expense having to do with warranty service, prior to any work or shipping expense is incurred. Equalizer Systems also reserves the right to authorize the location and technician to perform the service.

In the event that service must be performed, Equalizer Systems will provide labor coverage only for the allotted time issued on the "Equalizer Systems Parts Replacement Schedule" at a reasonable shop rate. Equalizer Systems will determine reasonable shop rates.

Equalizer Systems will not be responsible for improper installations, damage due to improper installation, or service, performed by parties other than Equalizer Systems. Equalizer Systems will not be responsible for any damage due to abuse, neglect, misuse, negligence, misapplication, error of operation, accidental or purposeful damage. This warranty extends to the Equalizer System only, and does not extend to the vehicle to which the Equalizer System is attached or any other apparatus or property, loss of time, manufacturing costs, labor material, loss of profits, consequential damages direct or indirect or incidental damages, whether due to rights arising under this warranty or otherwise, and whether a claim for damages is based on contract, tort, or warranty.

Written permission for any warranty claim return must be first obtained from authorized Equalizer Systems personnel. All warranty parts must be accompanied by a complete written explanation of claimed defects and the circumstances of failure.

Products manufactured or sold by Equalizer Systems are not warranted expressly or by implication for merchantability or fitness for a particular use, notwithstanding any disclosure to Equalizer Systems of the use to which the product is to be put. This express warranty is the sole warranty of Equalizer Systems. Equalizer Systems does not authorize the sale of its products under any other warranty or guarantee, expressed or implied.

This warranty voids all previous issues. Effective date: November 1, 2002. Any questions concerning this product warranty should be directed to:

Equalizer Systems
P.O. Box 668, 55169 CR 3 North
Elkhart, IN 46515
Phone: (574) 264-3437 Fax: (574) 266-6083

[Back](#)

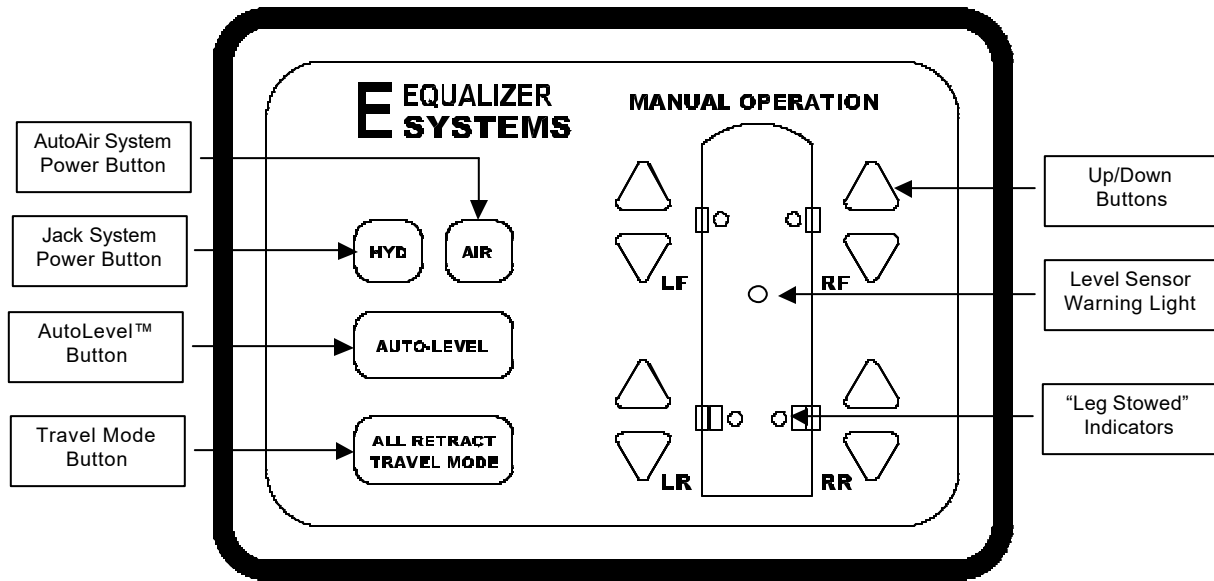

AutoLevel™ Control Panel

AutoAir™ System Power Button

This button powers up the AutoAir™ system (if equipped). After depressing this button, you will be able to manually raise and lower the individual chassis airbags. This is helpful when manually leveling the coach prior to re-setting the [Null](#). By depressing this button followed by depressing the AutoLevel™ button, the AutoAir™ system process is activated.

Jack System Power Button

This button powers up the hydraulic jack AutoLevel™ system. After depressing this button, you will be able to manually raise and lower the individual jacklegs. This is helpful when manually leveling the coach prior to re-setting the [Null](#). By depressing this button followed by depressing the AutoLevel™ button, the AutoLevel™ jack system process is activated.

AutoLevel™ Button

This button activates the AutoLevel™ process. It is used for either Air or Hydraulic jacks, depending on which system has been activated by its respective power button.

Travel Mode Button

In the AutoAir mode, this button disables the airbag leveling system and returns control of the airbags back to the chassis ride-height valves.

In the AutoLevel™ hydraulic mode, this button retracts all of the jacks to their up/stowed position.

Up/Down Buttons

In the AutoAir™ mode, these buttons are used to inflate or deflate each individual airbag to manually level the coach body.

In the AutoLevel™ hydraulic mode, these buttons are used to extend or retract each individual hydraulic jackleg to level the coach.

Level Sensor Warning Light

This red LED will light if there is any disruption of the signal between the level sensor and the control panel.

“Leg Stowed” Indicators

These red LEDs will be off when the jacklegs are completely retracted into their stowed position. If any of these LEDs is on, that particular jackleg is out of its stowed position and is partly, or completely, extended.

Audio / Visual signals

The control panel has been designed to generate a series of both audio signals and visual signals to indicate a given function of the panel. These signals can be very useful in troubleshooting a problem with the system in general and with the panel specifically. For a complete list of these signals, [click here](#).

Null

The Null setting tells the solid-state level sensor where level is. The procedure is as follows:

1. Using the individual Up/Down buttons on the Control Panel and some sort of bubble level, manually adjust each airbag until the coach is level, both front-to-back and side-to-side.
2. Turn off power to the control panel, if on.
3. Depress and hold the “AutoLevel” button on the control panel, then depress the “Air” button. The panel will begin to beep repeatedly.
4. After the panel beeps 6 or 7 times, release the “AutoLevel” button. The Null is now set.

Setting the Null

The Null setting tells the solid-state level sensor where level is. This procedure has been initially done at the factory, but will need to be reset if either a new control panel or a new level sensor has been installed.

The procedure is as follows:

1. Turn on power at the control panel.
2. Using the individual Up/Down buttons on the Control Panel and some sort of bubble level, manually adjust each jack leg until the coach is level, both front-to-back and side-to-side.
3. Turn off power to the control panel.
4. Depress and hold the "AutoLevel" button on the control panel, then depress and release the "Power" button. The panel will begin to beep repeatedly.
5. After the panel beeps 6 or 7 times, release the "AutoLevel" button. The Null is now set.

Note – If the coach is equipped with the optional AutoAir™ System, either system – Air or Hyd – can be used to level the coach for this procedure.

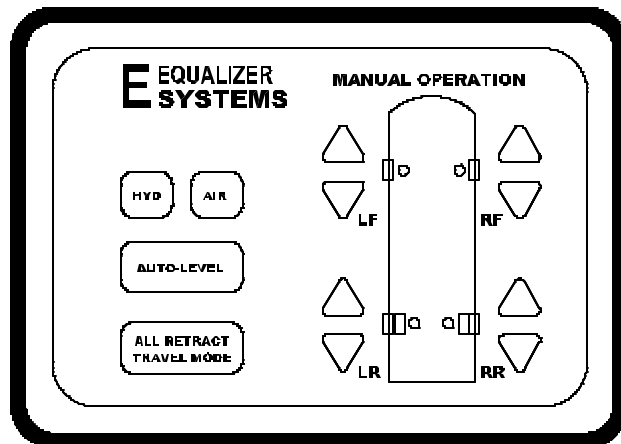

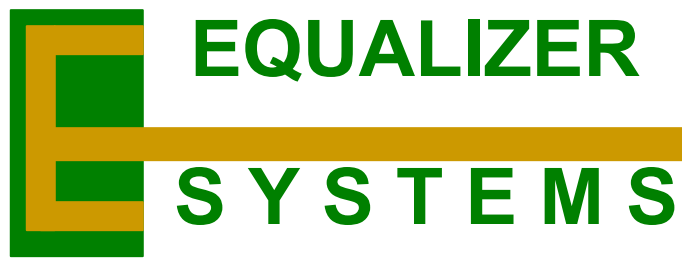

AutoLevel™

System Overview

The AutoLevel™ leveling system consists of a hydraulic system containing four hydraulic [jack legs](#) connected to a hydraulic [pump](#) and manifold assembly by a series of hydraulic hoses. This hydraulic system is controlled by an electrical system containing an electric [harness](#), a [level sensor](#) and a microprocessor [control panel](#) that is the brains of the entire AutoLevel™ system.

Basic Operation

The initial level condition of the coach is done by manually lowering - then adjusting - the four jack legs using the [Up/Down buttons](#) located on the right side of the control panel. For reference, a set of bubble levels is used: one for side-to-side level and another one for fore-aft level. Once the proper level condition is established, the system [Null](#) is set. This tells the system that, anytime the Autolevel™ command is initiated, this is the level condition the system needs to bring the coach to. The system will do this within an accuracy of +/- 0.5 degree of the Null setting.

When the [Autolevel™](#) button is pressed, the system first dumps the chassis air bags, then extends the jack legs one at a time, beginning with the front left jack and moving clockwise to the right front, right rear and left rear jacks. The system will extend each jack just until the jack makes contact with the ground. This is called planting the jacks. (The chassis air bags are dumped to lower the coach entry step as close to the ground as possible.)

Once all jacks are planted, the control panel's patented software will "read" the tilt being sent to it by the level sensor. It will then compare this to the Null setting previously determined during the setting process. The software will then calculate which corner of the coach needs to be raised (or lowered) to bring the coach into level condition, and send the appropriate signals to the Hydraulic pump

to adjust the jacks. The entire Autolevel™ process takes only 30 to 45 seconds to complete.

When the coach needs to be moved, the [“All Retract/Travel Mode”](#) button is pressed and the jacks will all retract together. The system will also return control of the chassis air bags back to the ride-height valves, which will re-inflate the bags. This entire process takes between one and three minutes, depending on the condition of the batteries and the amount of chassis air available.

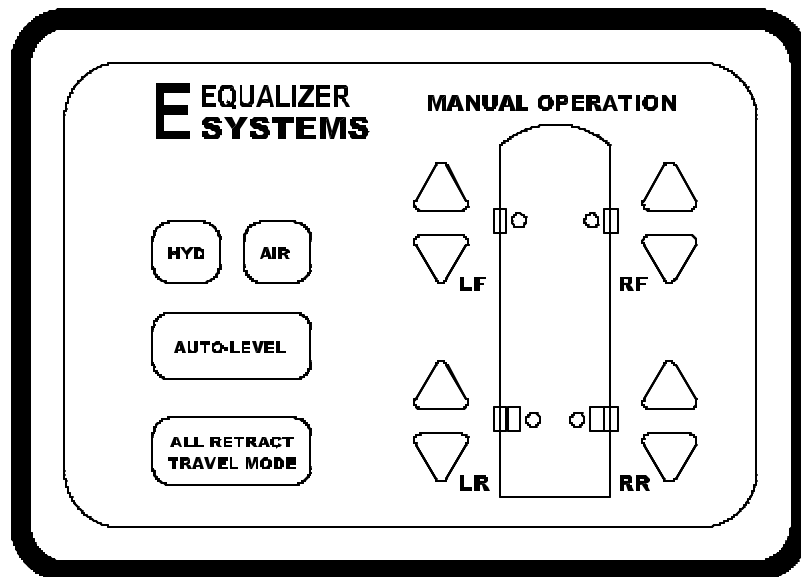

[Back](#)

OEM Troubleshooting Guide-Hyd AutoLevel

Symptom	Possible Cause	Corrective Action
Control Panel will not turn on	Blown fuse on back of Panel or in fuse box Broken power or ground wire Defective Control Panel harness Low battery voltage Defective Control Panel	Replace fuse Trace and repair Trace and repair Charge Vehicle batteries Replace
Panel on but jacks won't operate	Low battery voltage Defective Diode in Panel harness (if equipped) Defective Control Panel Bad electrical connection Defective Pump motor or solenoid	Charge Vehicle batteries Repair Replace Trace and repair Replace
Jacks will retract but not extend	Low battery voltage System Null not set Defective Leg Switch Ignition switch in wrong position Defective Control Panel Bad electrical connection	Charge Vehicle batteries Set Null Replace Check and change if necessary Replace Trace and repair
Jacks will extend but not retract	Incorrect Hose connection at pump or jack Incorrect wiring on pump valves Defective Control Panel	Trace and repair Check and re-wire Replace
Auto-Level stops in mid-cycle	Low battery voltage Excess vehicle movement during leveling System Null not set Defective Leg Switch Level Sensor harness defective Level Sensor defective Defective Control Panel	Charge Vehicle batteries Reset Control Panel and try again Set Null Replace Trace and repair Replace Replace
Leg LED's on Panel stay on	Defective Leg Switch Defective Control Panel	Replace Replace
Hydraulic pump inoperative	Low battery voltage Defective Pump motor or solenoid Blown fuse in fuse box Bad electrical connection	Charge Vehicle batteries Replace Replace Trace and repair
Legs bleed down from leveled position	Air in Hydraulic System Defective cartridge valve (s) on pump	Purge the System Replace cartridge valve(s)

[Home](#)

[Back](#)

[Drawings](#)

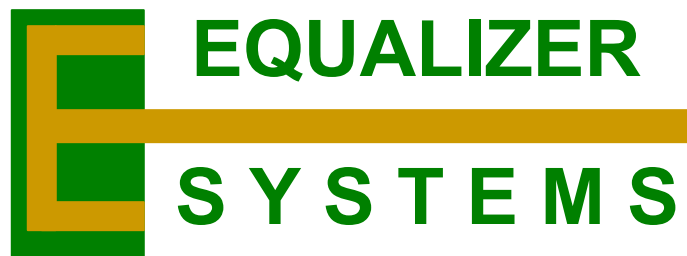

AutoLevel™ System Drawings

Hydraulic

- Pump assembly – Components
- Pump assembly – Electrical
- Pump assembly – Hydraulic
- Jack Leg assembly – 16”
- Jack Leg assembly – 18”
- Level Sensor assembly
- Hydraulic Control Panel

AutoAir

- Air System Schematic
- Air Valve
- Compressor
- Air Tank Assembly
- Wiring Harness
- Air Control Panel

[Back](#)

Operation of Hydraulic Level System Manual Override

If electrical power is ever lost to the Equalizer jack leveling system, your system has been equipped with a manual override option. The following procedure will guide you step by step on how to initialize the manual override to either retract or extend the leveling jacks.

To RETRACT one or more Jacks

1. Locate the Jack System Pump

The pump on your coach is located behind the access panel at the very right rear of the coach.

2. Initializing the Leg Valves

Locate the Leg Valve(s) for the legs you want to operate (Items 1-4 on drawing). Using a SMALL flat blade screwdriver, turn the center screw all the way in (clockwise).

3. Initialize Manual Override Valve

Locate Valve #5 located on the back of the pump. Pull the center red knob out and rotate ½ turn in either direction.

4. Initialize the Directional Valve

For RETRACT only, locate Directional Valve #6 located on the front of the pump. Pull the center red knob out and rotate ½ turn in either direction.

5. Operate the Hand Pump

Locate Hand Pump handle. Insert handle into the Hand Pump collar located on the front of the pump. Begin pumping the handle. Continue operating Hand Pump until jack(s) begin to retract. Note: It may require 50 to 100 strokes before any movement is noticed in the jack(s). Continue operating Hand Pump until jack(s) are retracted.

6. Return System to Normal Mode

Once the jacks are retracted, you must return the Valves back to their normal modes. CAUTION: Failure to do this may result in one or more jacks drifting down from their retract (stowed) position. For Valves 1-4, rotate the center screws fully in the counter-clockwise direction. For Valves 5 and 6, simply rotate the red knob until it snaps back into its normal position.

To EXTEND jack(s), follow the above procedure EXCEPT do not initialize the Directional Valve as described in Item #4 above.

[Back](#)

HYDRAULIC JACK LEG PUMP WITH MANUAL OVERRIDE

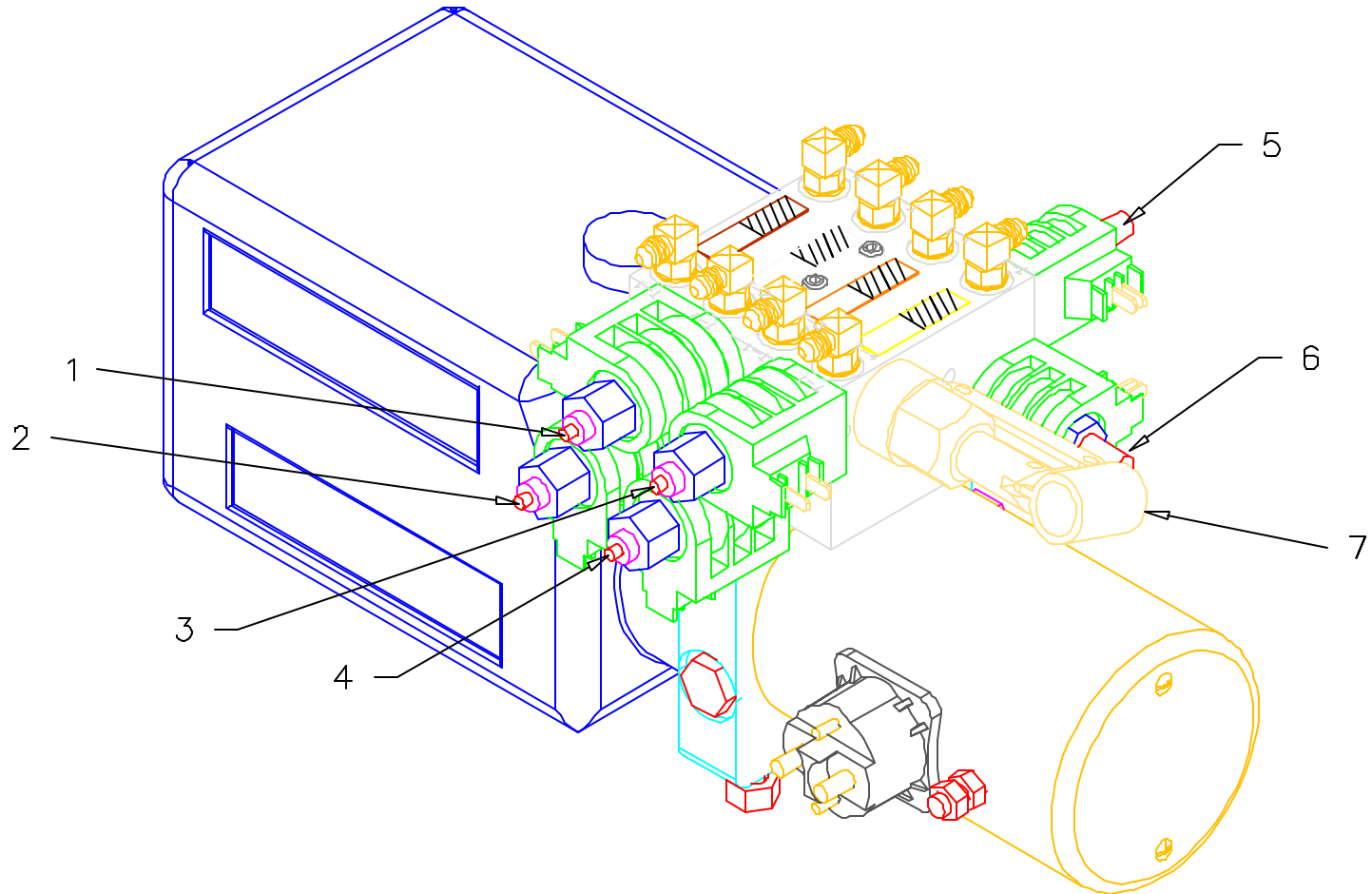

ITEM #	DESCRIPTION
1	VALVE - LEFT FRONT LEG
2	VALVE - RIGHT FRONT LEG
3	VALVE - LEFT REAR LEG
4	VALVE - RIGHT REAR LEG
5	MANUAL OVERRIDE VALVE
6	DIRECTIONAL VALVE
7	HAND PUMP COLLAR

Return

AutoAir System Overview

Description

Under certain circumstances, it is necessary or desirable to level the coach body but, because of local restrictions, the normal hydraulic AutoLevel™ jacks cannot be used. Equalizer Systems' AutoAir leveling system functions by leveling the body of the coach using the chassis airbags. A solid state level sensor reads the level condition of the coach body and, by either inflating or deflating the appropriate chassis airbag(s), brings the body into a level condition. The system will periodically re-check the level condition and, if necessary, make minor adjustments to re-level the body.

Operation

Upon parking the coach, setting the park brake, shutting off the engine and extending the slide-outs, momentarily depress the "[Air](#)" button on the AutoLevel™ control panel. This powers up the system. Momentarily depress the "[AutoLevel](#)" button to activate the system.

The coach airbags will deflate for about one second - this helps to insure that the coach step is not too far above the ground. After a slight pause to allow the level sensor to "see" where it is, the AutoLevel™ process begins. (NOTE – it is important to limit the amount of movement in the coach during the leveling process. Excess movement will cause the system to shut down.) This process takes about one minute to complete.

About every two hours, the system controller will re-check the level condition and, if necessary, make minor adjustments to re-level the body.

When ready to travel, the system is deactivated in one of two ways. The first is to momentarily depress the "[All Retract Travel Mode](#)" button on the control panel. The other way is to momentarily depress the "[Air](#)" button on the control panel, thereby shutting off the system.

Detailed function

The system consists of several components.

- A special [Control Panel](#), which contains a microprocessor, controls the functions of the system.
- A series of four [Air Valves](#) that are located under the coach near the air bag that each valve controls. Each valve is installed between an air bag and either the chassis Ride-Height valve or the chassis ping tank(s). During the AutoAir leveling process, these valves block the path between the bags and the Ride-Height system, giving them control of the bags.
- An auxiliary [Air Tank](#), which supplies air to the AutoAir system if there is no air in the chassis air tank.
- An auxiliary [Air Compressor](#), which re-charges the auxiliary Air Tank as needed. The compressor is controlled by means of an air pressure switch located on the Air Tank.
- An electrical [Harness](#), which ties the Control Panel and the Air Valves together. This harness consists of two sections. One section runs from the Control Panel to the chassis bulkhead, and another section that runs from the bulkhead to the Air Valves.
- A series of air lines and fittings, which plumb the Air Valves together with the Air Tank.

Troubleshooting Guide-Air AutoLevel

Symptom	Possible Cause	Corrective Action
	Low battery voltage	Charge Vehicle batteries
	Vehicle Ignition on	Turn off ignition
	Blown fuse on back of Panel or in fuse box	Replace fuse
Control Panel will not turn on	Broken power or ground wire	Trace and repair
	Defective Control Panel harness ground	Trace and repair
	Defective Control Panel	Replace
	Low battery voltage	Charge Vehicle batteries
	No air in chassis air system	Start engine and allow air system to charge
Panel on, but airbags won't operate from panel	System Null not set	Set Null
	Bad electrical connection	Trace and repair
	Park Brake not set (optional)	Set Park Brake
	Defective Control Panel	Replace
	Low battery voltage	Charge Vehicle batteries
	Excess vehicle movement during leveling	Reset Control Panel (All Retract) and try again
Auto-Level stops in mid-cycle	System Null not set	Set Null
	Level Sensor harness defective	Trace and repair
	Level Sensor defective	Replace
	Defective Control Panel	Replace
	Aux. Air supply not functioning	Blown fuse to Aux. Compressor
System fails to maintain long-term level condition	Excessive air leak	Trace and repair
	Pressure switch on Aux. Air tank	Replace
	Aux. Compressor Relay defective	Replace
Panel will not control one or more airbags	Defective Control Panel harness	Trace and repair
	Defective Control Panel	Replace
	Defective air Valve(s)	Replace defective valve(s)
One or more airbags will not re-inflate to Ride Height	No air in chassis air system	Start engine and allow air system to charge
	Defective air Valve(s)	Replace defective valve(s)
	Defective chassis component	Consult Chassis Service Center
Home	Back	Drawings

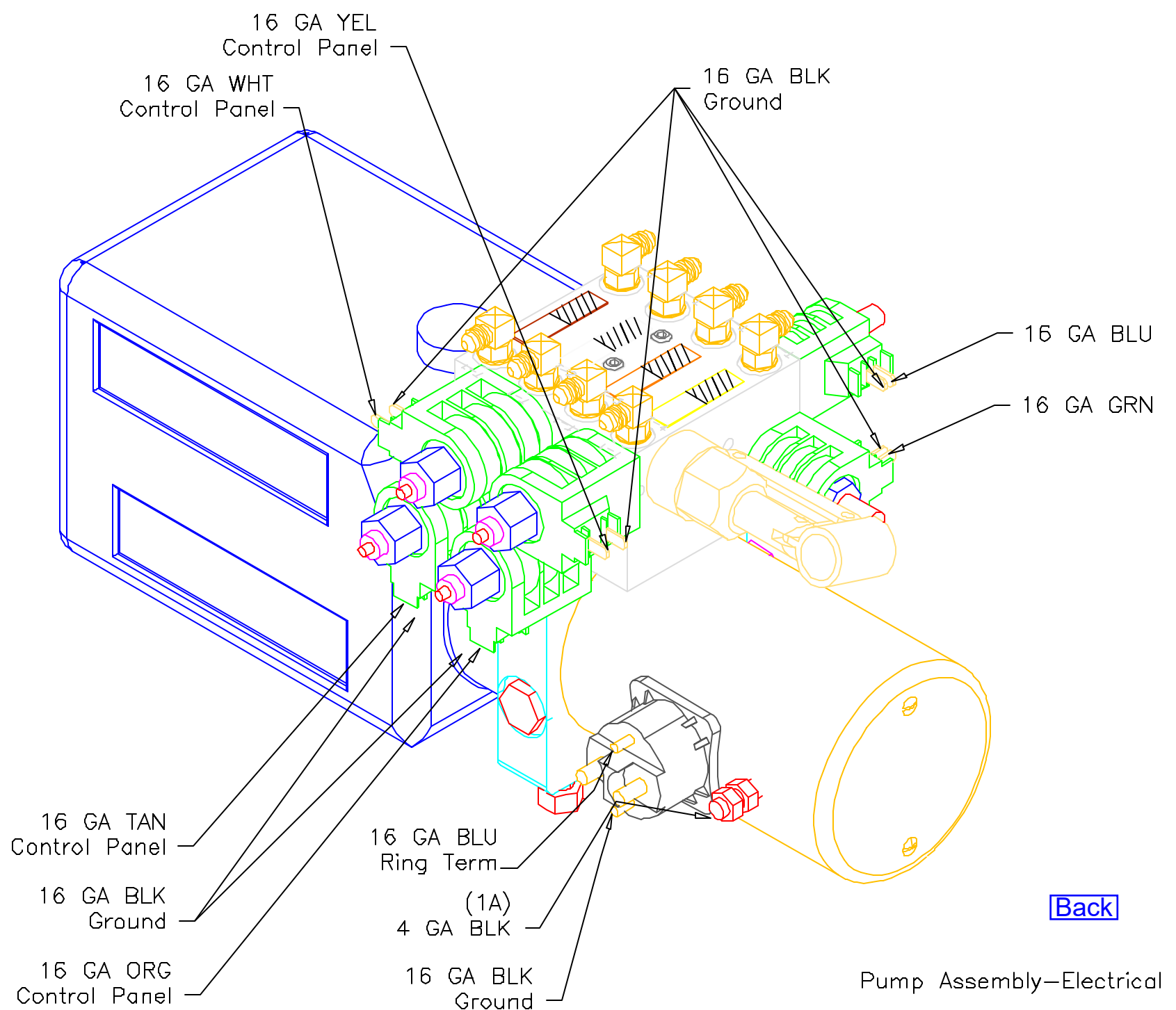

[Back](#)

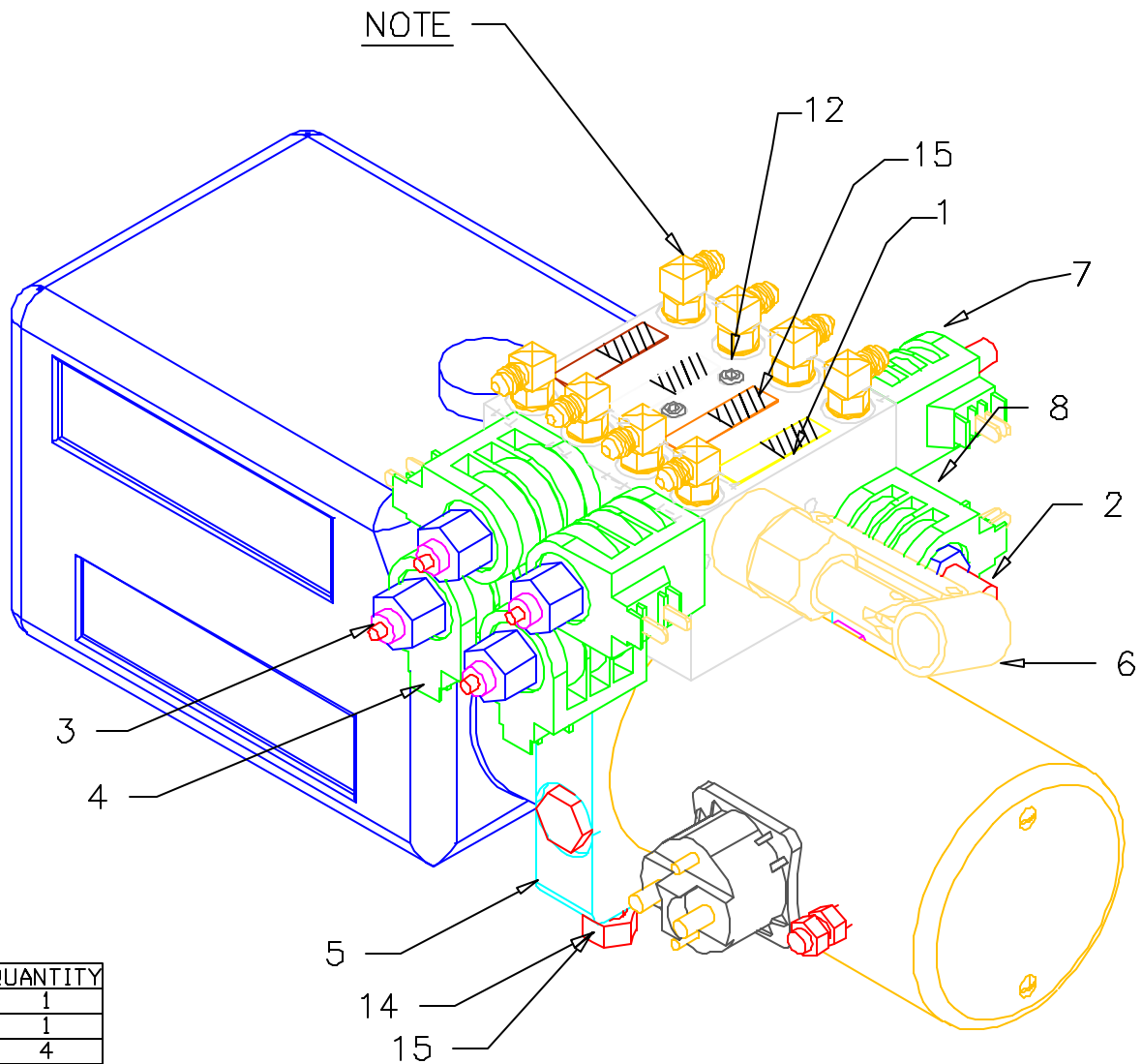

Pump Assembly – Components

ITEM #	PART # / DESCRIPTION	QUANTITY
1	#1710 - MANIFOLD-4 FUNCTION	1
2	#1717 - DIRECT. VALVE-#6 MAN O/RIDE	1
3	#1716 - CART. VALVE-MAN O/RIDE	4
4	#1130 - DDS 12 COIL	4
5	#1768 - PUMP SPX LARGE - HD	1
6	#1720 - HAND PUMP, HIGH VOLUME	1
7	#1745 - #8 2-POSITION 1 WAY VALVE	1
8	#1746 - COIL #6 10V	1
9	#1776 - HAND PUMP HANDLE (NOT SHOWN)	1
10	#1831A - 4-WAY GND LEAD (NOT SHOWN)	2
11	#1841A - SHCS 1/4-20 x 3 SCREW	2
12	#1215 - HARNESS-PUMP (NOT SHOWN)	1
13	#1892DD - STUD	2
14	#1278 - SHOULDER NUT	2
15	LABELS - HOSE COLOR CODE	8

[Back](#)

NOTES

This assembly must be mounted level with the coach floor

- Ⓐ This arrow must point toward the front of the coach
- Ⓑ This arrow must point up

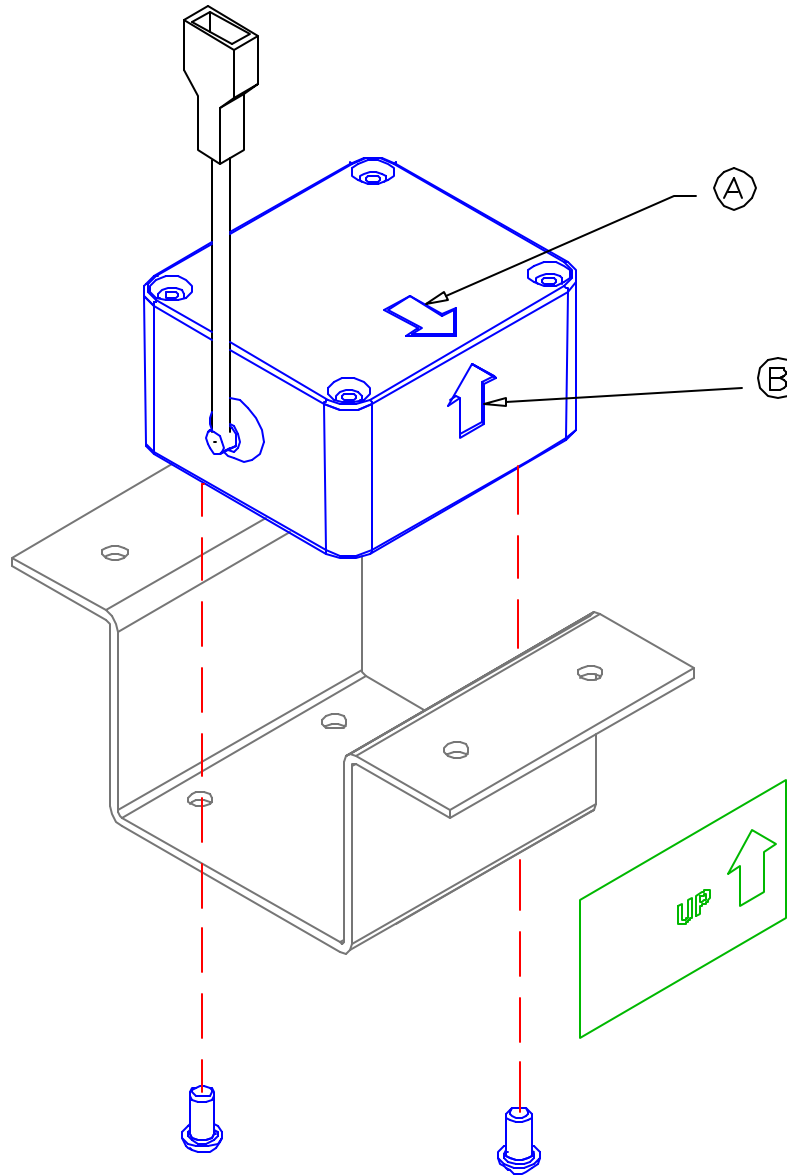

P/N 7196 Level Sensor Assembly
Available as Assembly only

[Back](#)

[Back](#)

Jack Leg Assembly-18"

ITEM #	PART # / DESCRIPTION	QUANTITY
1	#1601 - CYLINDER - 18"	1
2	#1682 - PLUNGER SWITCH	1
3	#1818C - LEG SWITCH SCREWS	2
4	#1799 - GASKET	1
5	#1683 - 10X10 FOOT	1
6	#1383 - 3/4-10 SCREW	1

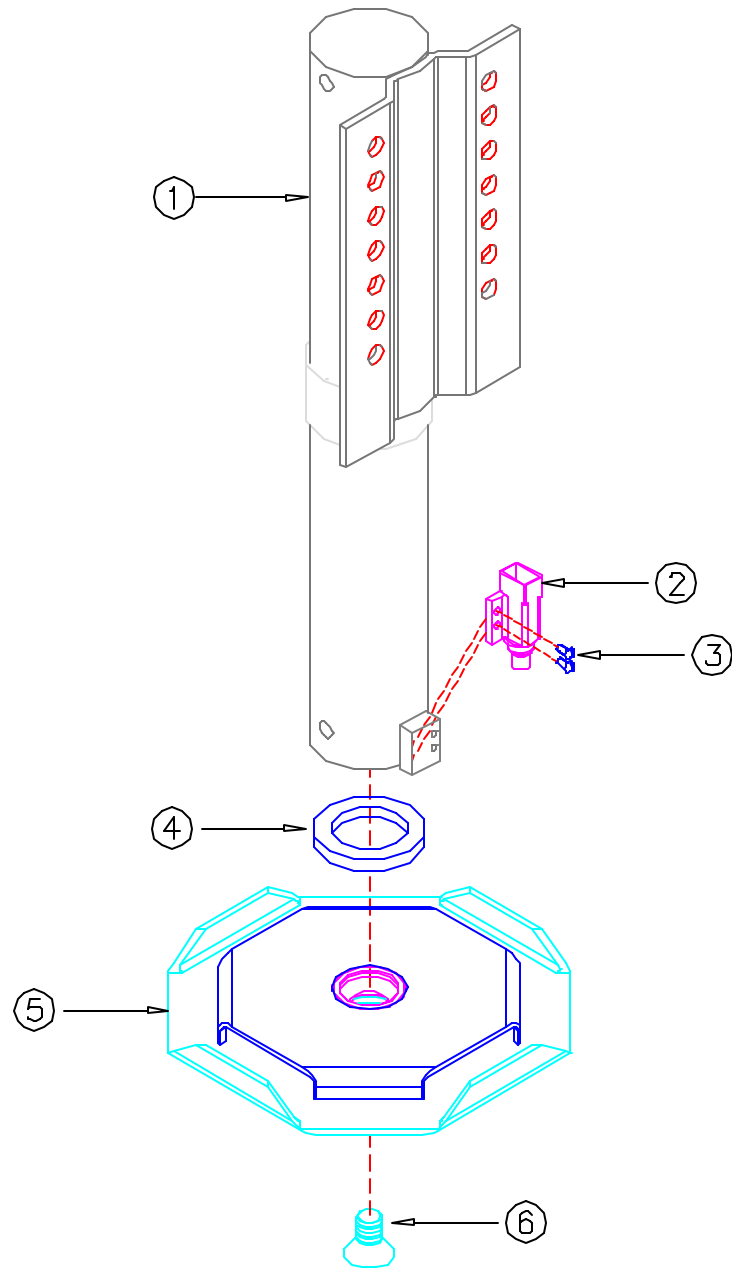

Back

Jack Leg Assembly-16"

ITEM #	PART # / DESCRIPTION	QUANTITY
1	#1592 - CYLINDER	1
2	#1682 - PLUNGER SWITCH	1
3	#1818C - LEG SWITCH SCREWS	2
4	#1799 - GASKET	1
5	#1683 - 10X10 FOOT	1
6	#1383 - 3/4-10 SCREW	1

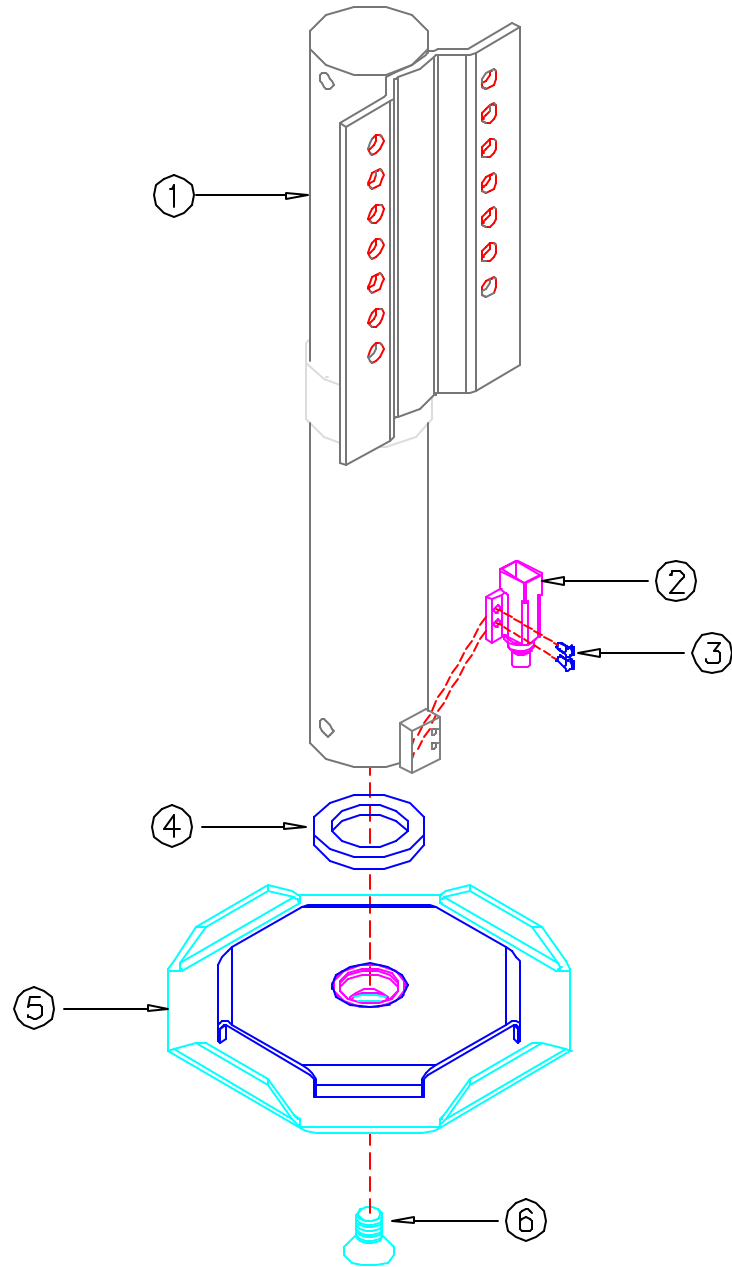

Front View

IMPORTANT – Null Panel before attempting any operation

- 1 – Press and hold AutoLevel button
 - 2 – Press and release Power button
 - 3 – Listen for 5 or 6 beeps
 - 4 – Release AutoLevel button
- Null is set

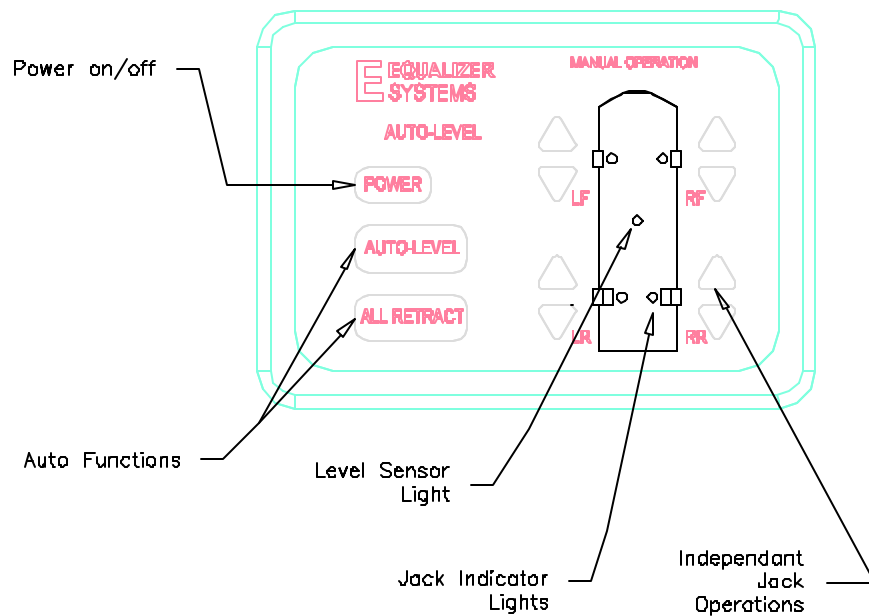

Rear View

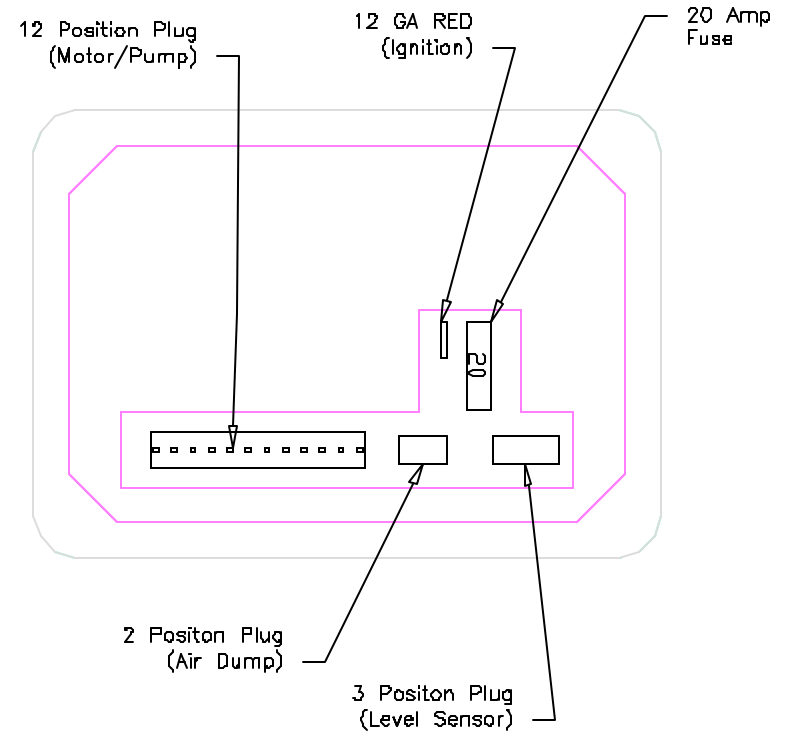

P/N 1703 Control Panel—Hydraulic

[Back](#)

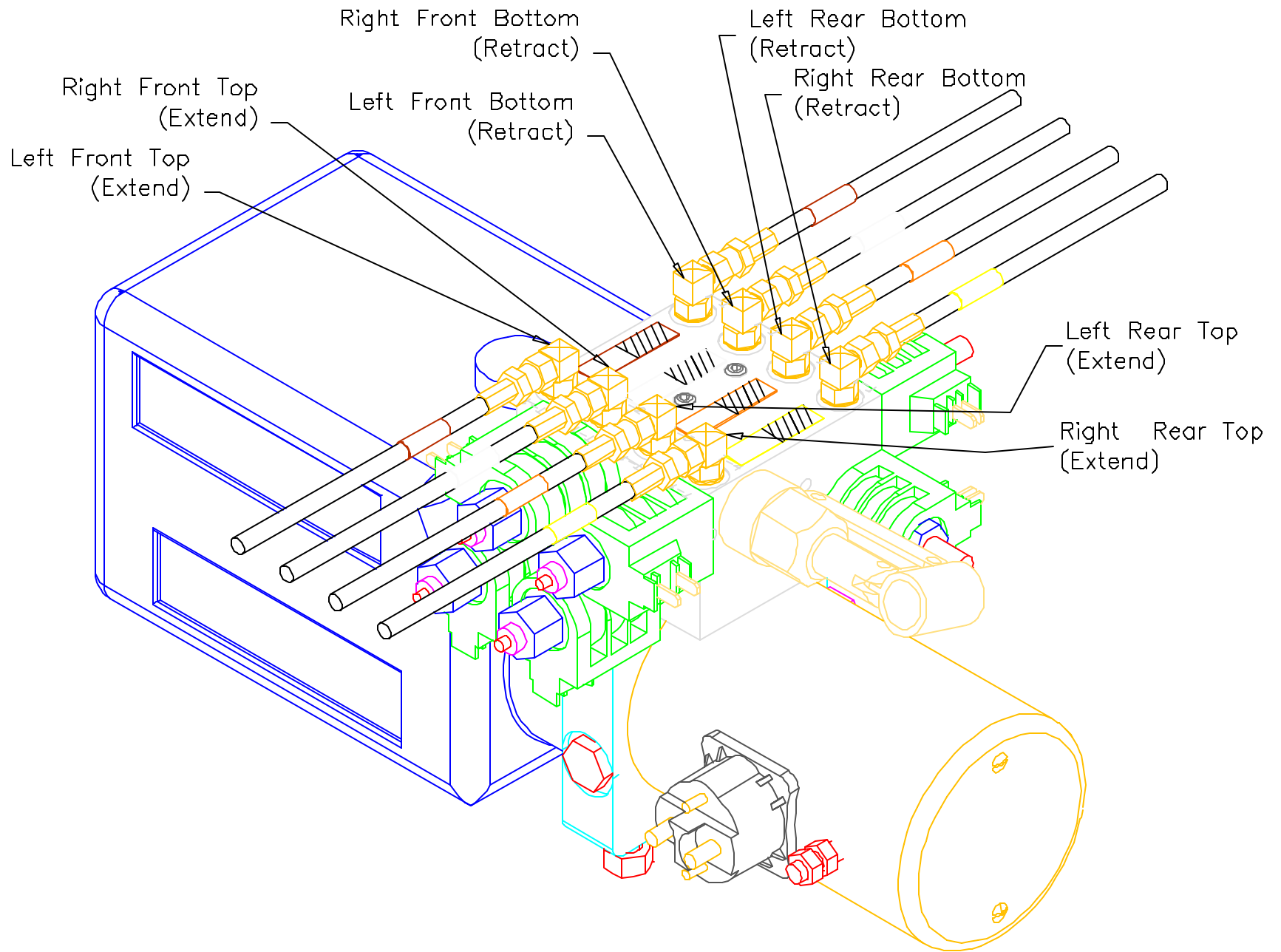

[Back](#)

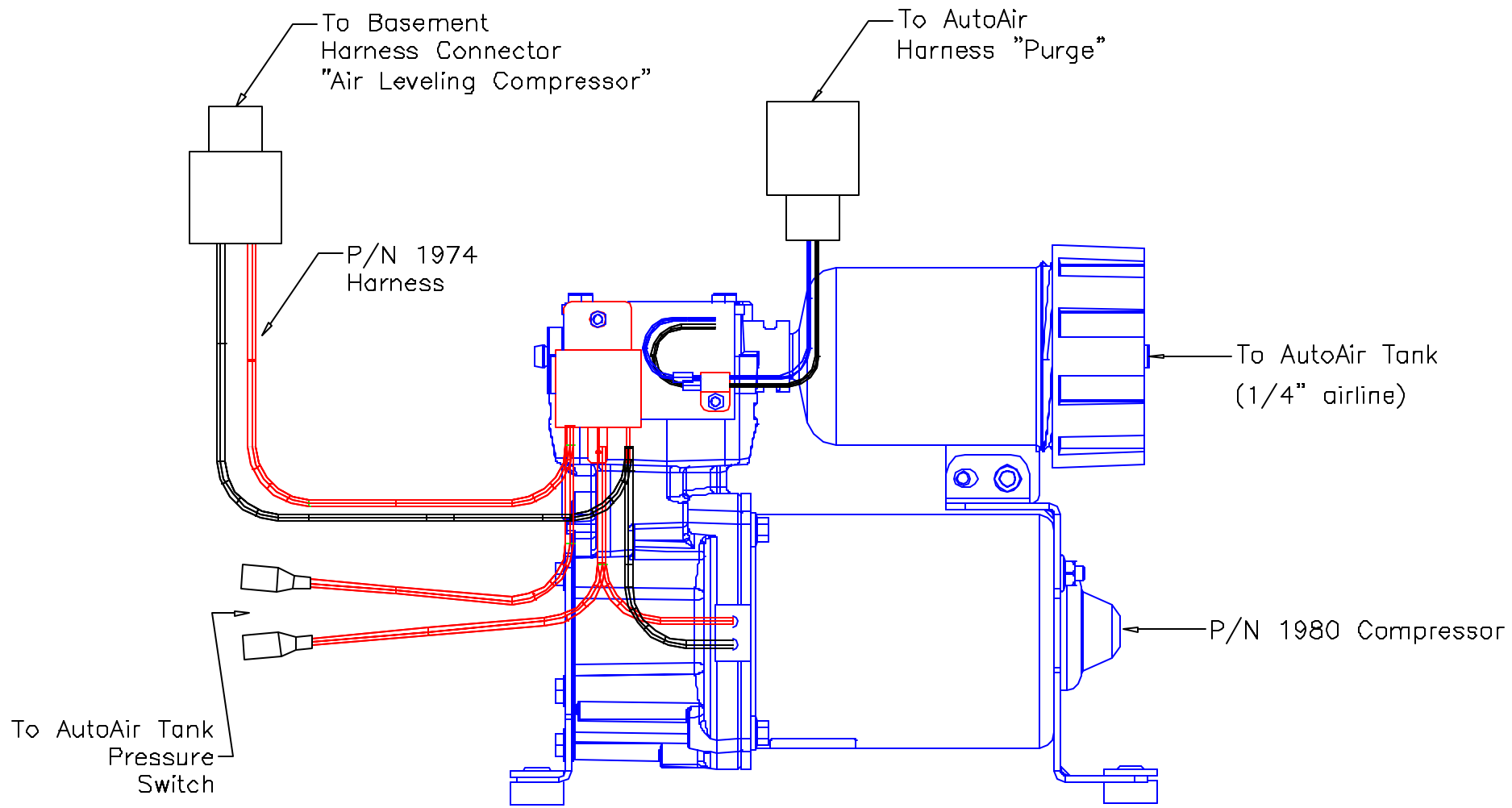

Relay is Bosch P/N 0 332 019 110
or equivalent

Compressor Assembly

[Back](#)

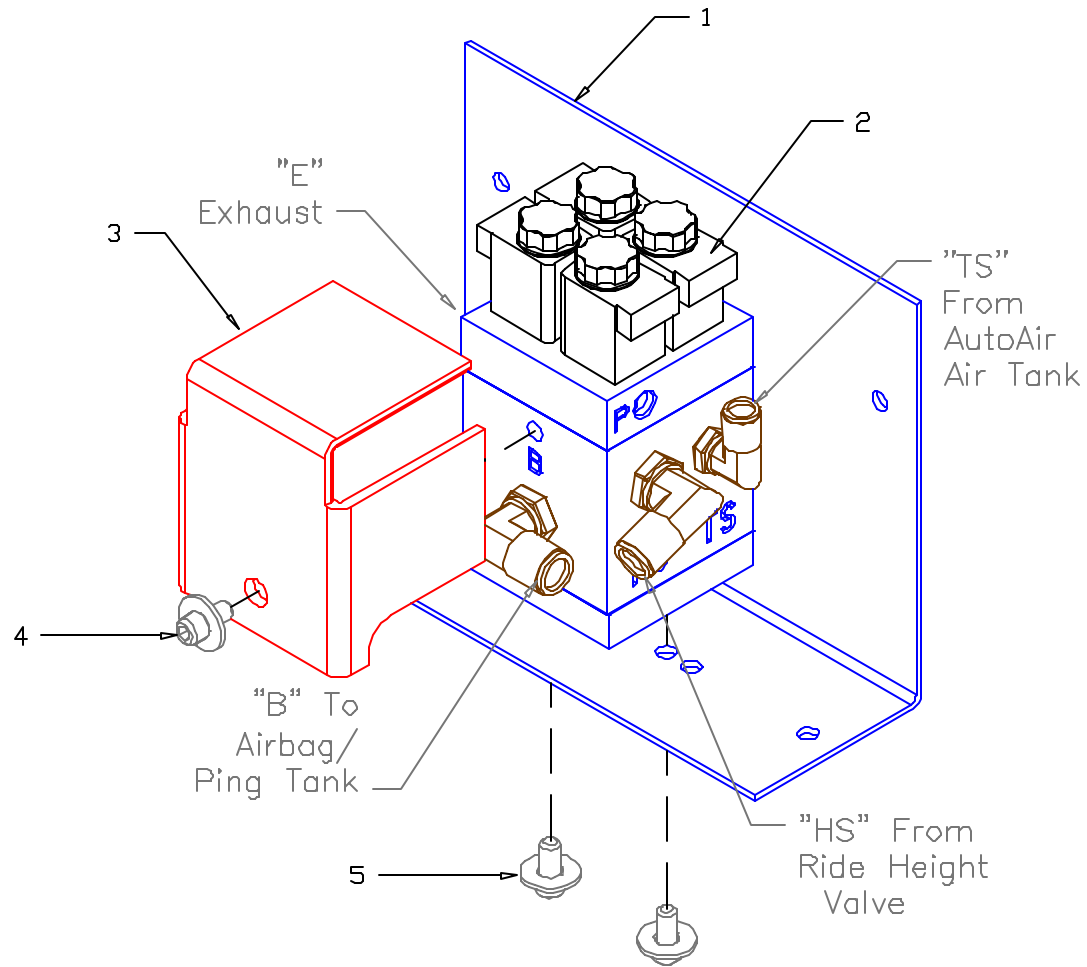

Air Valve Assembly-Typical

ITEM #	PART # / DESCRIPTION	QUANTITY
1	#1212 - Bracket-Air Valve	1
2	#1979 - Air Valve	1
3	#1985 - Shroud	1
4	#1917A - 1/4-20 SHCS	3
5	#1898DD - 1/4" Lock Washer	3

[Back](#)

ITEM	PART # / DESCRIPTION	QUANTITY
1	1972 - DRAIN PETCOCK	1
2	1973 - AIR TANK	1
3	1975 - PRESSURE SWITCH	1
4	1976 - AQ69 SWIVEL FITTING	2
5	1977 - MALE/FEMALE ELBOW	1
6	1999 - MALE/MALE ELBOW	1
7	1984 - CHECK VALVE	1
8	1995 - AQ66 QUICK CONNECT	1

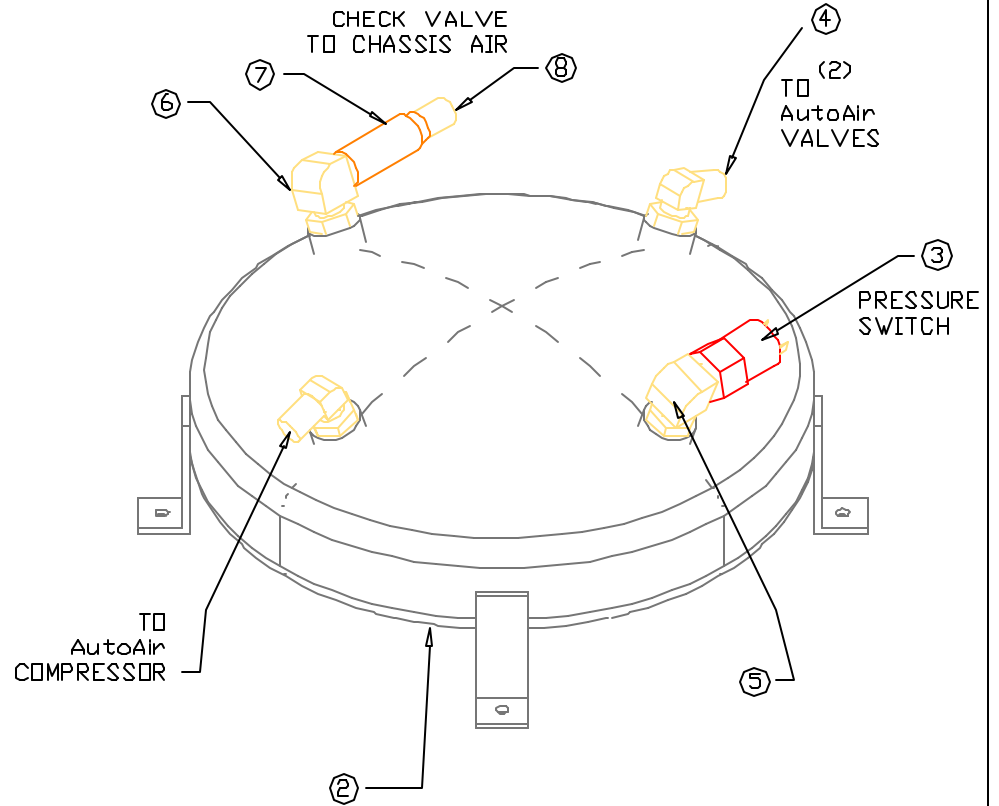
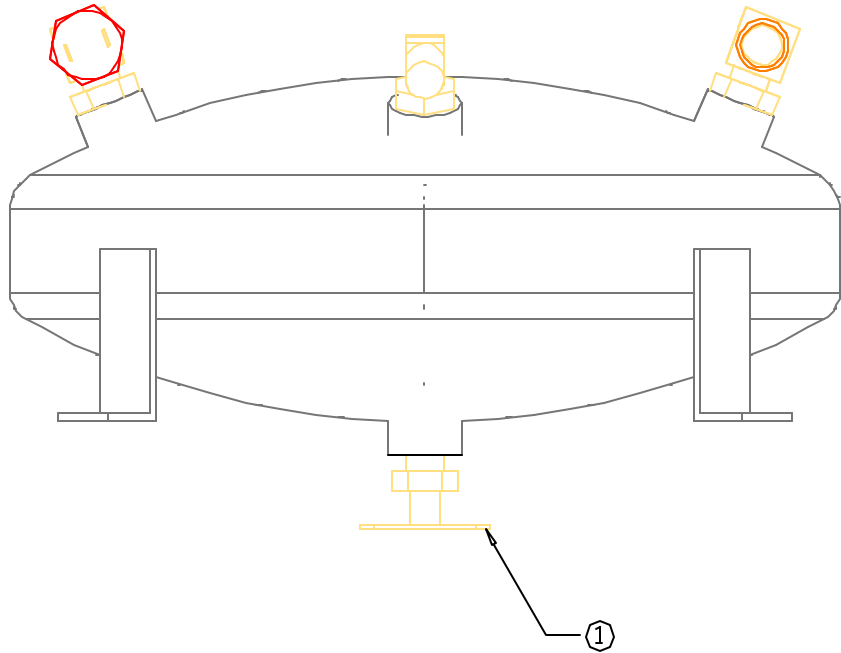

Air Tank Assembly

[Back](#)

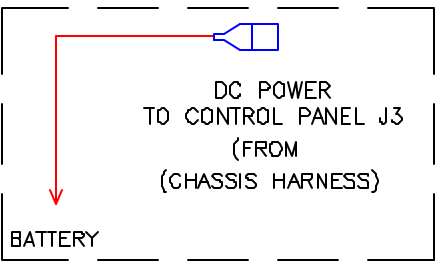
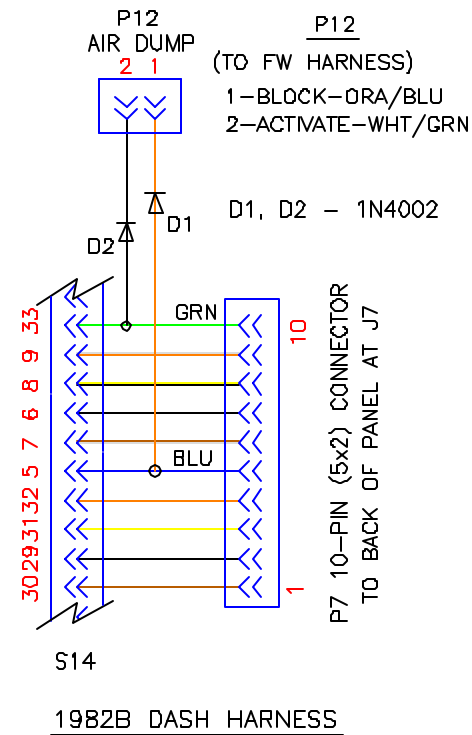
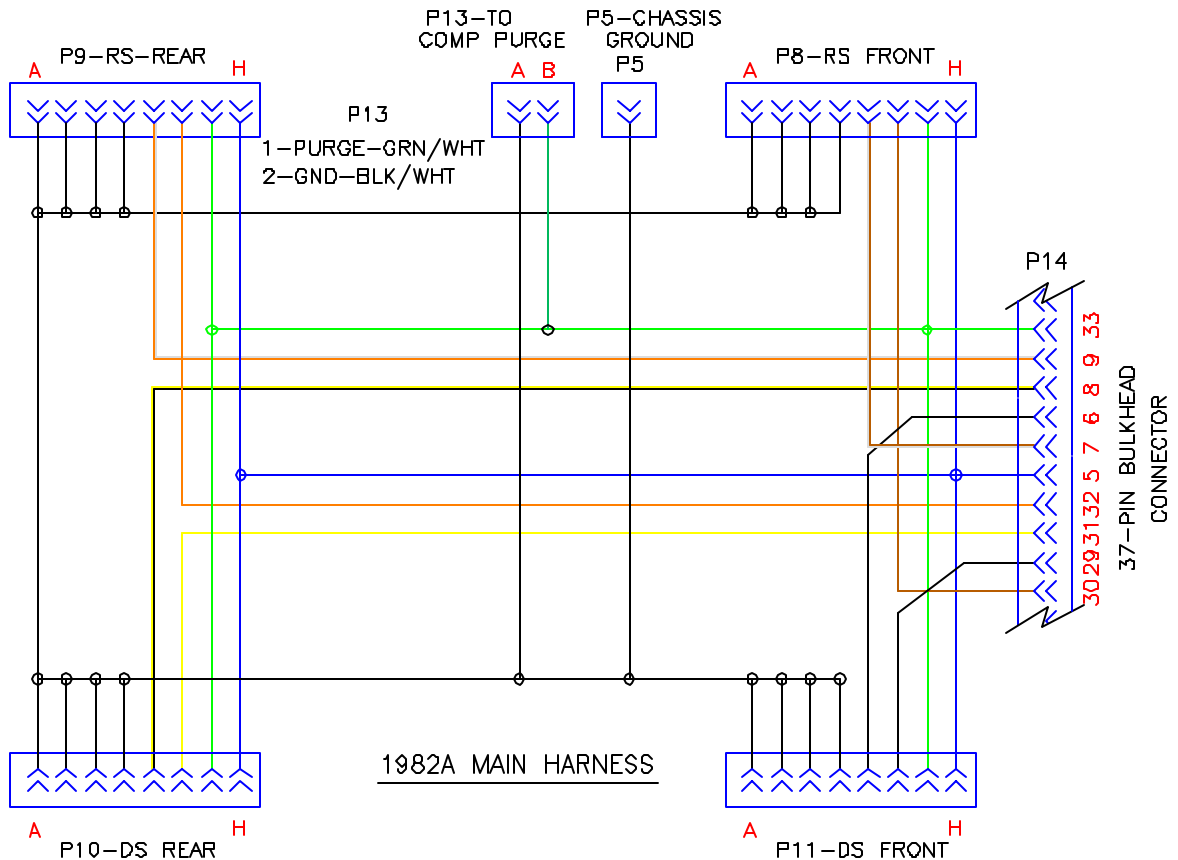

P7

TERM	FUNCTION	COLOR
1	LF INFLATE	BROWN
2	RF INFLATE	WHITE
3	RR INFLATE	YELLOW
4	LR INFLATE	ORANGE
5	BLOCK AS	BLUE
6	LF DEFLATE	BRN/TRACE
7	RF DEFLATE	WHT/TRACE
8	RR DEFLATE	YEL/TRACE
9	LR DEFLATE	ORA/TRACE
10	ACTIVATE AS	GREEN

P14

TERM	FUNCTION	COLOR
5	BLOCK AS	BLUE
6	DS FRONT DEFLATE	WHT/TRACE
7	RS FRONT DEFLATE	BRN/TRACE
8	DS REAR DEFLATE	YEL/TRACE
9	RS REAR DEFLATE	ORA/TRACE
29	DS FRONT INFLATE	WHITE
30	RS FRONT INFLATE	BROWN
31	DS REAR INFLATE	YELLOW
32	RS REAR INFLATE	ORANGE
33	ACTIVATE AS	GREEN

P/N 1982 MAIN HARNESS—AutoAir

[Back](#)

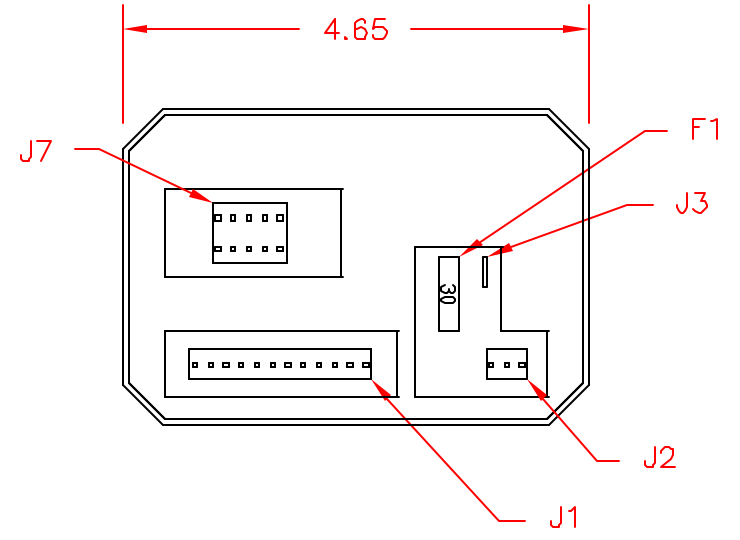
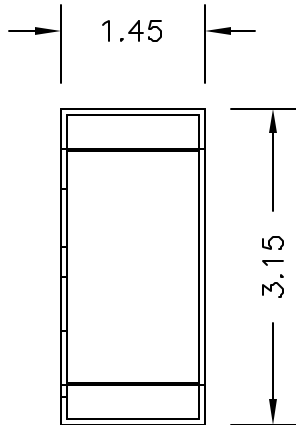
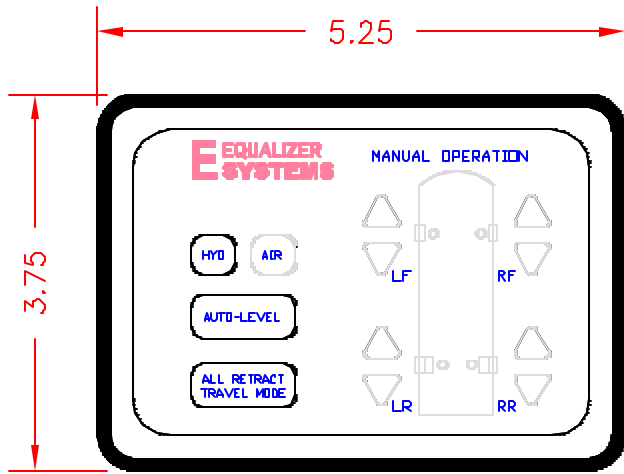

- J1 - TO HYD SYSTEM
- J2 - TO LEVEL SENSOR
- J3 - TO IGNITION
- J7 - TO AIR LEVEL HARNESS
- F1 - FUSE, 30A ATC

[Back](#)

P/N 1978 Control Panel with AutoAir

[Back](#)

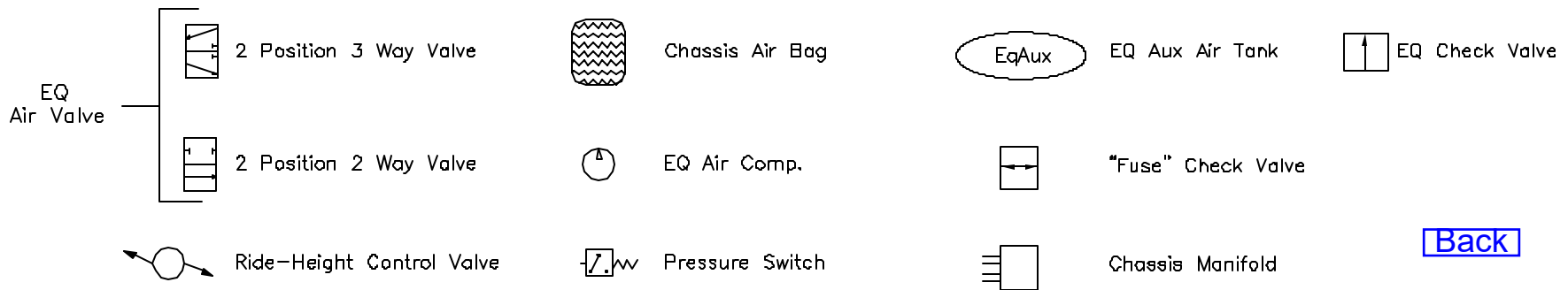
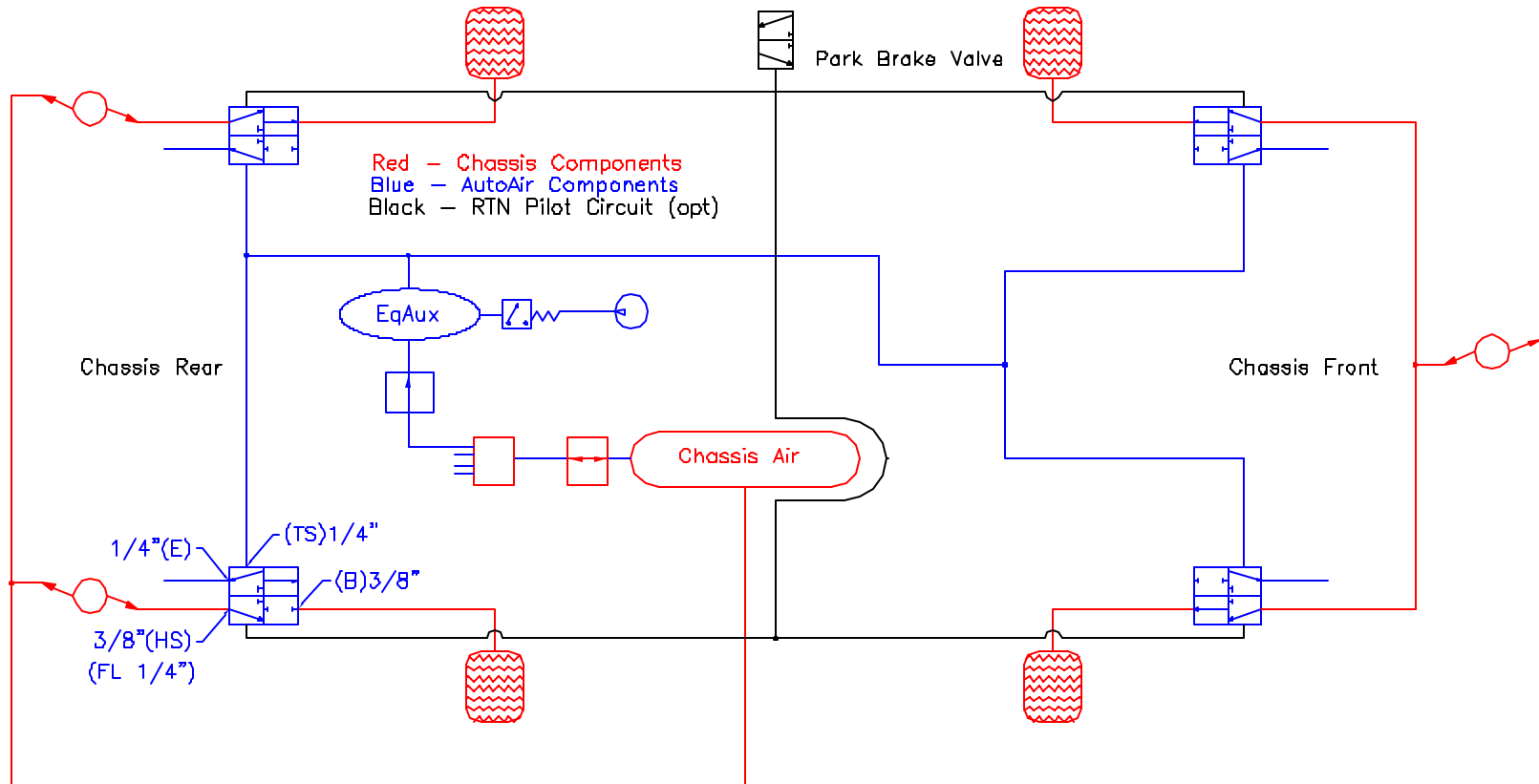

[Back](#)

Visual Status Outputs

#s	Status LED	Description	LED Color	
1	Power Sw	Backlight Location LED when voltage is above 10.0V +/- 0.5V Backlight Location LED when voltage is below 10.0V +/- 0.5V	Green	On OFF
		Warning LED when Voltage is above 10.0v +/- 0.5V Warning LED when Voltage is below 10.0v +/- 0.5V	Red	Off On
2	AutoLevel Sw	ALV is activated and in progress	Green	Flash
		Error condition - Any leg that fails to unstow initiates an error condition. Any switch press or power off will clear the error condition.	Red	On
3	All Retract Sw	All Retract is activated and in progress	Green	Flash
		Error condition – any leg, which fails to stow. Any switch press or power off will clear the error condition.	Red	Flash
4	LF Leg Stow Status LED	LF Leg is stowed LF Leg is extended	Red	Off On
		Error condition – anytime leg fails to unstow during AutoLevel or fails to stow during All Retract	Red	Flash
5	RF Leg Stow Status LED	RF Leg is stowed RF Leg is extended	Red	Off Of
		Error condition – anytime leg fails to unstow during AutoLevel or fails to stow during All Retract	Red	Flash
6	LR Leg Stow Status LED	LR Leg is stowed LR Leg is extended	Red	Off On
		Error condition – anytime leg fails to unstow during AutoLevel or fails to stow during All Retract	Red	Flash
7	RR Leg Stow Status LED	RR Leg is stowed RR Leg is extended	Red	Off On
		Error condition – anytime leg fails to unstow during AutoLevel and anytime fails to stow during All Retract	Red	Flash
8	All @ Power-Up	Backlight - All Location LEDs, except Power switch not in use	Green	On
		Visual Test – All Warning/Error LEDs located under AutoLevel switch and All Retract/Travel Mode switch, all Stow LEDs Plus Sensor LED. Power switch red & green LEDs, which is not selected, do not turn On	Red	1.5-sec
9	Sensor	Sensor is On and communicating with ALV No sensor data is available Sensor data in intermittent due to harness failure Noise on sensor line	Red	Off On Flash On
10	Heartbeat	Processor is active	Red	Flash

[BACK](#)

Audio Status Outputs

#s	Audio Status	Description
1	Denied w/Disable On	Continuous tone sounded while switch is pressed.
1a	Denied w/No Disable	Uh-Uh tone sounded each time a switch is pressed
2	Failed	Dual low tone ("Uh-Uh")
3	Passed	Hi tone, Low tone. ("Bedoop")
4	Warning	½ sec. Low tones plus ¼ sec. High tones– 10-second timeout
5	Auto Operating	½ sec. Hi tones.
6	Auto Operating failed.	¼ sec. Hi tone pulse. Indicates a continuously present error condition, which is probably indicated by one or more leg status LEDs. – continuous until any switch is pressed to clear the error condition
7	System Reset	Short series of ¼ sec Hi tones – (power reset)

Timer Table

#s	Function	Timer	Description
1	All Retract - Max	90-seconds	All legs will retract automatically for a maximum of 90-seconds
2	Pump Extra On Time	3-seconds	Pump outputs for Up and Down will remain On for and extra 3-seconds extra time after all legs have been stowed
3	Unstow	2-seconds	In clockwise direction, each leg is unstowed for 2-seconds, then each leg is checked for stow position at 2-sec after each leg plant sequence is initiated sequentially
4	Leg Plant Max	40-seconds per leg	Each legs is extended individually for leg plant a maximum of 40-seconds – calculated individually for a combined max total of 160-sec
5	Auto-Level Max	90-seconds	Auto-Level sequence, starts after Leg Plant is completed and will only try to achieve level for a maximum of 90-seconds
6	Hydraulic Sleep Mode	10-minutes	Module will enter sleep at 10-minutes if the power is On and there is no keypad activity
7	Airbag Cloaking Mode	10-minutes	Module will enter sleep at 10-minutes if the power is On and there is no keypad activity
8	Airbag Cloaking Mode	2-hours 5-minutes	Module will wake-up every 2-hours to check level, if level it will go back to sleep, if not level it will wake-up and initiate an auto-level sequence
9	Blocking	2-seconds	Anytime power to hydraulic or air is turned On or Disable is not present Off, there will be a 2-second blocking signal
10	Return to Normal	1-second	Anytime power to hydraulic or air is turned Off or Disable is present, there will be a 1-second Return to Normal signal
11	Hydraulic Deflate	5-seconds	Anytime Auto-Level is initiated there will be 5-second All Deflate signal
12	Airbag Deflate	1-second	Anytime Auto-Level is initiated there will be 1-second All Deflate signal

[BACK](#)

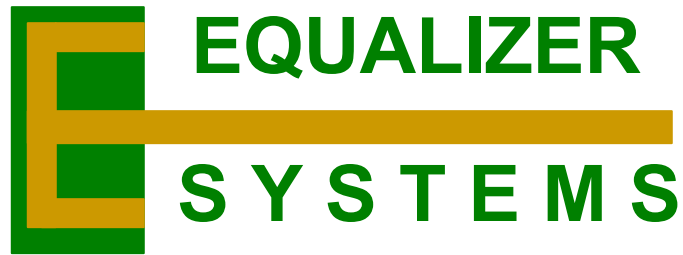

Hydraulic System Purge Process

After the installation of the hydraulic jack system, the system must be purged of air, which is replaced with hydraulic fluid. Occasionally, this process is not done adequately and some air will remain in the system. This causes the jacks not to run as efficiently as they should, and may result in the jack legs sagging out of their stowed (retracted) position. This procedure will solve the problem.

- Make sure the pump reservoir is filled with hydraulic fluid. There is a fill line on the reservoir.
- Using either the manual buttons or the All Retract button on the [Control Panel](#), fully retract all of the jacks.
- Re-check the fluid level – add as necessary.
- Using the manual buttons on the Control Panel, **fully** extend all jacks to their maximum extension. This will require alternating between the front two jacks and the rear two jacks – the cross-frame twist limiter in the Control Panel will not allow you to fully extend one jack at a time. Keep the jacks extended for at least 15 minutes.
- Again, fully retract the jacks. Re-check the fluid level – add as necessary.

The process is complete.

[Back](#)

This manual has been provided courtesy of
My RV Works, Inc.

www.myrvworks.com



You can find more RV service manuals here:

www.myrvworks.com/manuals

Over the years of running a mobile RV repair service, having a dedicated place to access service manuals for all the different appliances and components found on RVs was something that I always had a desire to create.

I hope this resource makes your RV repairs easier, as it has mine, but please be careful and follow proper safety practices when attempting to repair your own RV.

If in doubt, please consult with a professional RV technician!



DARREN KOEPP - OWNER, MY RV WORKS, INC.

All service manuals provided on www.myrvworks.com are believed to be released for distribution and/or in the public domain.